

Ex Libris



From the Gliding Library of
Wally Kahn

KRONFELD ON
GLIDING AND SOARING

Bill Kronfeld (Son)

J. R. W. KRONFELD.

SILVER 'C' No 1126 29-4-62.

GOLD 'C' No 108 20-6-63.

Simon Kronfeld.

SIMON R. M. KRONFELD (GRANDSON).

SILVER 'C' No 9234 13-8-93

GOLD 'C' No 1252 2-10-26



A SOUVENIR OF THE AUTHOR'S VISITS TO ENGLAND

Left to Right: Herr Robert Kronfeld (in the machine); Mr. Ashwell Cooke (President of the London Gliding Club); H.R.H. The Prince of Wales; Mr. Gordon England (President of the the British Gliding Association)

Frontispiece

KRONFELD ON
GLIDING AND SOARING
THE STORY OF MOTORLESS HUMAN FLIGHT

By
ROBERT KRONFELD

Translated by J. MANCHOT

PREFACE by COLONEL THE MASTER OF SEMPILL



PUBLISHERS
JOHN HAMILTON, LTD.
LONDON

Made and Printed in Great Britain by the **KEMP HALL PRESS, LTD.**
in the City of Oxford

CONTENTS

	<i>page</i>
THE STORY OF MOTORLESS HUMAN FLIGHT	I
THE HISTORY OF SOARING FLIGHT	17
TIME BRINGS THE ANSWER	25
SPEEDIER PROGRESS	33
THE WRIGHTS	40
FAMOUS CONTEMPORARIES	45
FRANCE	46
ENGLAND	49
BACK TO GERMANY.	52
TEN YEARS OF COMPETITION—TEN YEARS OF EXPERI- ENCE	54
THE ROUSSEAU OF FLYING	55
RECORDS	62
THE LEAN YEARS	70
ON THE WAY TO SCIENTIFIC FLYING	79
OUR EFFORTS REWARDED	90
THE FIRST SIXTY-MILE SOARING FLIGHT.	97
SOARING PILOTS REPORT	106
NEHRING TELLS THE TALE I	106
NEHRING TELLS THE TALE II	108
LIEUTENANT DINORT REPORTS	111
OUR FIRST SOARING FLIGHT IN AMERICA BY P. LAUBENTHAL	114

	<i>page</i>
A RECORD FLIGHT ABOVE THE CLOUDS AND OVER THE SEA BY WOLFRAM HIRTH	120
ABOVE THE RHÖN AS A PASSENGER IN A MOTORLESS PLANE BY DR. ALFRED DETIG	121
SOME FLIGHTS OF MY OWN	131
I MY RIDE WITH THE THUNDERSTORM	131
II A BLIND FLIGHT IN A SOARING PLANE	135
III SIXTY MILES ALONG THE TEUTOBURGER WALD	140
IV SOARING IN A SNOWSTORM	145
THE GLIDING AND SOARING SCHOOL	148
ON THE WAY TO THE " B " TEST	168
THE SOARING COURSE	178
HIGH PERFORMANCE FLIGHTS	187
LONG-DISTANCE SOARING	198
CLOUD-SOARING AND THUNDERSTORM-SOARING.	210
AUTO AND AEROPLANE TOWING	227
THE AUTO-TOWED START	234
SOME RULES FOR INSTRUCTION IN TOWED FLIGHT	241
WINDLASS STARTS	244
AEROPLANE TOWING	
(1) THE AEROPLANE.	246
(2) THE TOWED GLIDER	248
THE CONSTRUCTION OF GLIDING AND SOARING PLANES	253
WEATHER, WIND AND CLOUDS	290
THE FUTURE OF SOARING FLIGHT	306
THE PROGRESS OF SAILPLANING THROUGHOUT THE WORLD	317
THE ENGLISH CHANNEL FLIGHT	341
MY SOARING FLIGHTS OVER LONDON	348
MY SOARING FLIGHTS IN ENGLAND.	352

LIST OF ILLUSTRATIONS

A SOUVENIR OF THE AUTHOR'S VISITS TO ENGLAND

No.	<i>Frontispiece</i> Plate facing page
1. AN EVENING FLIGHT OVER THE DUNES OF ROSSITTEN	4
2. A "ZÖGLING" STARTING OFF	5
3. THE "CHARLOTTE," A TAILLESS SOARER	16
4. THE RHÖN-ROSSITTEN COMPANY'S TAILLESS SOARER, THE "STORCH"	17
5. THE COMPETITION IN 1920, FOR WHICH MANY HANGING GLIDERS WERE ENTERED	17
6. OTTO LILIENTHAL, THE "FATHER OF SOARING FLIGHT"	26
7. ONE OF THE NUMEROUS HANGING GLIDERS BUILT BY LILIENTHAL	27
8. OTTO LILIENTHAL'S LAST MACHINE, IN WHICH HE CRASHED TO HIS DEATH IN 1896	34
9. A WRIGHT GLIDER OF 1902	35
10. A VIEW OF THE WORKSHOP OF ETRICH AND WELS	46
11. MARTENS IN THE "MORITZ," AND THE DOUBLE- SEATER OF THE DARMSTADT FLYING GROUP	47
12. THE MACHINE BUILT BY KLEMPERER FOR THE AACHEN FLYING CLUB	54
13. "KONSUL," THE MACHINE BELONGING TO THE DARMSTADT ACADEMIC FLYING GROUP	55
14. THE TAILLESS MACHINE IN WHICH LEUSCH CRASHED TO HIS DEATH.	55
15. The "ESPENLAUB 5" IN FLIGHT	70
16. FERDINAND SCHULZ IN HIS "BROOMSTICK"	71

No.		Plate facing page
17.	THE QUICK RELEASE OF ESPENLAUB'S SOARING PLANE	74
18.	A RUSSIAN SOARER ON THE RHÖN IN THE 1925 MEETING	75
19.	THE FAMOUS AIRCRAFT DESIGNER, FOKKER	82
20.	SOLDENHOFF'S TAILLESS MOTOR-PLANE	82
21.	THE WASSERKUPPE DURING THE 1926 COMPETITION	83
22.	NEHRING, A VERITABLE MASTER IN THE ART OF SLOPE-SOARING	86
23.	THE DARMSTADT ACADEMIC FLYING GROUP'S D.18	87
24.	THE DARMSTADT ACADEMIC FLYING GROUP'S "MOHAMED"	87
25.	THE "RAPACE," A FRENCH SOARER	94
26.	THE "DUCK"	95
27.	A TAILLESS ROCKET MODEL TAKING OFF	95
28.	THE AUTHOR'S RETURN FROM HIS FIRST CLOUD FLIGHT	98
29.	A GROUP OF SOARING FLYERS AT THE RHÖN IN 1928	99
30.	THE "RHÖNGEIST" BEING PREPARED FOR A FLIGHT	102
31.	KRONFELD IN THE "WIEN"	103
32.	KRONFELD'S RECORD FLIGHT BY THE HELP OF CLOUD SOARING	104
33.	LIGHT WIND SOARER IN WHICH LIEUTENANT DINORT ACCOMPLISHED HIS FAMOUS DURATION FLIGHT	105
34.	CUMULUS SEEN FROM ABOVE	105
35.	THE PILOT'S SEAT IN THE "WIEN"	134
36.	PUPILS PRACTISING OVER LEVEL GROUND	135
37.	THE PLANE IN FLIGHT, SKETCH A	150
38.	" " " " B	150
39.	" " " " C	151

LIST OF ILLUSTRATIONS

ix

No.		Plate facing page
40.	THE PLANE IN FLIGHT, SKETCH D	151
41.	” ” ” ” E	154
42.	” ” ” ” F	154
43.	GLIDING FOR A STALL	155
44.	STALLING : THE MOST DANGEROUS FAULT COMMITTED BY BEGINNERS	162
45.	THE FUSELAGE OF THE MUNICH ACADEMIC FLYING GROUP'S " KAKADU "	163
46.	CLIMBING FLIGHT OF A SOARING PLANE	166
47.	AN OBSTACLE IN THE COURSE OF FLIGHT	167
48.	CURVES CAUSED BY WIND PRESSURE	182
49.	NORMAL SOARING FLIGHT ON SLOPE	183
50.	TURNING CURVE IN A STRONG WIND	186
51.	TURNING CURVE IN A CALM	187
52.	LANDING UPHILL WITH THE WIND BEHIND	194
53.	PLANE ON A SLOPE IN A FRESH BREEZE	195
54.	PLANE ON A SLOPE IN A GENTLE BREEZE	198
55.	CLOUD SOARING	199
56.	ATTEMPT TO SOAR WITH THE CLOUDS	214
57.	CLOUD SOARING	215
58.	DISTANCE FLIGHT TO A FIXED POINT, WITH RETURN TO STARTING POINT BY CLOUD SOARING	216
59.	DISTANCE FLIGHT TO A FIXED POINT, WITH RETURN TO STARTING POINT BY SLOPE FLYING	218
60.	DISTANCE FLIGHT ABOVE CLOUDS	230
61.	FLYING ALONG A THUNDERSTORM FRONT	231
62.	ESPENLAUB'S GLIDER THAT WAS TOWED BY A MOTOR-PLANE	234
63.	THE AUTO-TOWED START	235
64.	NORMAL AUTO-TOWED START	246
65.	AUTO-TOWED START IN DEAD CALM AND IN GALE	247
66.	STATIONARY MOTOR-WINDLASS.	250

No.		Plate facing page
67.	AEROPLANE TOW START	251
68.	TURNS IN AN AEROPLANE TOW START	254
69.	THE EARLY DAYS OF GLIDING	255
70.	A DIFFICULT LANDING IN A HANGING GLIDER	255
71.	A "ZÖGLING" IN THE AIR	258
72.	THREE LATTICED TAILS IN PROCESS OF CONSTRUCTION FOR "ZÖGLING" MACHINES	259
73.	THE FUSELAGE OF A LIGHT WIND MACHINE	259
74.	THE ELEVATOR	262
75.	FITTING THE RIBS ON TO A ONE-SPARRED WING	262
76.	WING STRUCTURE OF A PRIMARY MACHINE	263
77.	A SCHOOL DOUBLE-SEATER IN FLIGHT	263
78.	THE "RHÖNADLER"	278
79.	THE "ELIDA"	279
80.	THE "KAKADU" FUSELAGE ON THE SLIPS	286
81.	THE TRIPARTITE, ONE-SPARRED WING OF A HIGH-EFFICIENCY MACHINE	286
82.	A COMPETITION ON THE WASSERKUPPE	287
83.	THE "FAFNIR," FLOWN BY GÜNTER GROENHOFF	318
84.	THE "FAFNIR" TAKING OFF	319
85.	THE R.F.D. "DAGLING"	326
86.	THE "SCUD." A BRITISH INTERMEDIATE SOARING GLIDER	327
87.	THE R.F.D. SAILPLANE	342
88.	THE SOARING PLANE "AUSTRIA" IN FLIGHT	343
89.	A MOTH FITTED FOR TOWING GLIDERS	346
90.	HERR KRONFELD AND MISS SUSIE LIPPENS AT HANWORTH PARK	347
91.	HERR KRONFELD'S "AUSTRIA" AT HANWORTH PARK	354
92.	THE "AUSTRIA" VIEWED FROM BELOW	355
93.	DRAWING OF KRONFELD'S "AUSTRIA" IN FLIGHT	355

LIST OF DIAGRAMS

	<i>page</i>
BAROGRAM OF KRONFELD'S RECORD FLIGHT BY THE HELP OF THUNDERSTORM SOARING	101
BAROGRAM OF KRONFELD'S RECORD FLIGHT BY THE HELP OF CLOUD SOARING	104
ZÖGLING	258
PRÜFLING	261
HOLS DER TEUFEL	264
FALKE	262
MECKLENBURG M. III	267
HERCULES	268
BLAUE MAUS	271
VAMPYR	272
WESTPREUSSEN	274
LORE	275
STARKENBURG	277
LUFTIKUS	279
PROFESSOR	280
KRONFELD'S WIEN	282
FAFNIR	283
KASSEL 25	285
COMPARATIVE SIZES OF WELL-KNOWN SAILPLANES	287
KRONFELD'S GIANT SAILPLANE " AUSTRIA "	288
THERMAL UP AND DOWN CURRENTS	291
SMOKE FROM A CHIMNEY SHOWS THE TURBULENCE OF THE ATMOSPHERE	292
CURRENTS ON DETACHED ELEVATION	293

	<i>page</i>
CURRENTS ON HILLSIDE	294
STREAM OF CURRENTS ON SLOPES	296
CUMULUS PRODUCED BY WIND EDDIES	298
THE TWO FRONTS AND THE WARM SECTION IN AN AREA OF LOW PRESSURE	303
BIORKNES IDEALIZED CYCLONE	304
BAROGRAM OF FIRST LONG DISTANCE FLIGHT UNDER- TAKEN IN ENGLAND	358
HANGWIND	359
AACHEN MI	369
ANFÄNGER	370

FOREWORD

ALTHOUGH great strides have been made in the development of motorless flying in Germany, during the past ten years very little has been done until quite recently in this country. There was a very short spell of activity in 1922-23 which terminated in the birth of the light aeroplane as we know it to-day. From then until 1930 no progress was made here ; in fact, little interest was shown, except by a few, in the remarkable advances that were being made in Germany under the energetic direction of the Rhön-Rossitten Gesellschaft (the German Gliding Association) assisted by the Government of the Reich and municipal and other bodies.

In 1930 a few enthusiasts showed their faith in the future possibilities of motorless flying by founding the British Gliding Association. From the outset they realized that the only method of getting the movement on its feet would be by arranging for a series of practical demonstrations by a sailplane pilot with an international reputation. The pilot kindly lent for this purpose by the Rhön-Rossitten-Gesellschaft was the author of this book and we are indebted to him for the splendid demonstrations that he gave in 1930 and 1931 of the practical uses of a sailplane for scientific and sporting purposes. The machine on which these demonstrations were given was the famous "Wien"—a gift to Herr Kronfeld from the citizens of his native town.

Herr Kronfeld is not only a very skilful pilot but he has seriously studied the scientific aspects of aeronautics and meteorology and has an unusually broad experience that is indeed rare. These special qualifications, combined with a high degree of personal courage and skill, have enabled him to win a world-wide reputation and to achieve some truly remarkable flights under widely varying conditions. His flight to some seven thousand feet above the starting point (or ten thousand feet above sea level), and his

cross-country flight from the Wasserkuppe in Germany to the Czecho-Slovakian frontier are only two of the many fine flights to his credit.

His book, therefore, needs no introduction to those, whether deeply or generally, interested in this new art.

THE MASTER OF SEMPILL.

NOTE :

The author and the translator are indebted to Mr. and Mrs. Rudolf Flinsch for many kind and valuable suggestions and criticisms, as well as to Bernard and Roland Flinsch, who translated all the measurements in the book and helped to explain some difficult technical passages.

THE STORY OF MOTORLESS HUMAN FLIGHT

AS long as man has existed in our world, he has been animated by one longing—to fly. To free himself from the bonds of earth, to soar in the air like a bird!

So rooted is this idea in our natures that hardly one of us has not flown in his dreams, either as a bright angel or fantastic winged monster—according to his temperament and disposition.

This eternal aspiration found expression in many sagas and fairy tales. From it sprang Icarus, the dragons, the elves.

But man's dreams, sagas and fairy tales knew nothing of the droning engine. He had no wish to be whirled through the air by machinery; he longed to soar, fly and glide by his own unaided power.

“So after all we have not attained our desire,” you will say. But I answer: “Yes. Listen to what I have to tell you!”

Heavy clouds drift across the sky, and the stormwind howls in the treetops; the thunder awakens a hundred echoes in the mountains. But when all flee for shelter, one remains to defy the tempest.

Look! You may see him as a tiny dot that circles amid the black clouds more than eight thousand feet above our heads. He is a daring youth who has entrusted his life to a strange device that is shaped like a great bird and seems to be as light as a feather. Despite its vast span and light weight (it is hardly heavier than the pilot it carries), it is strong enough to withstand the onslaughts of the stormiest weather. But the greatest miracle of all is the fact that no engine helps its progress; it maintains itself in the air solely by aid of the savage forces of Nature, that human mind and will have mastered.

But if we would watch pilot and machine more closely, we must put aside these thoughts, for a heavy squall has almost pitched the plane on to its nose; the pilot has all

he can do to get it back on to an even keel amid the heavy clouds that threaten to swallow it. He must seek a way of escape from their embrace by making use of every favouring current and avoiding the unfavourable ones. He had just started when the storm broke. First he had a break-neck race with the thunder-clouds ; then he flew before the gale and often through its very midst. It was a wild ride ! his plane danced up and down, backwards and forwards, like some car on a fantastic, crazy switchback, but at last he won through, and now he has risen above the storm. Like a proud eagle, he serenely wings his silent way—to alnd at length some ninety miles from his starting-point, still laughing with the glee of his wondrous conflict and triumph.

Here is another vision for you ! Again a man hangs beneath the sky, but if you will see him, you must have good eyes, for it is pitch-black night. So dark it is that the pilot cannot even see his wingtips—which are swallowed up by the gloom. Although the breakers on the coast beneath him proclaim their proximity by eerie howls, he dare ride no higher, for he must keep in view the faint signal light at the turning point, which is his only visible object in this thick darkness.

Thus he flies for hours. While all good citizens lie wrapped in slumber, this silent ghost flits his rounds with the regularity of a clock.

Often his wings avoid scraping the dunes by a hair's-breadth, and it is well they do so, for the merest touch would hurtle him into the raging surf. Suddenly the breeze freshens ; the machine gains height and sails onwards until a grey dawn drives away the night.

These young soarers can do yet more. They wait on a hilltop in their machines until a huge, magnificent cloud rolls up ; then the thick rubber rope is hooked on to the machine, and some sixteen to twenty lusty youths tug at it. " Pull out ! " ¹ orders the pilot, and the sixteen yards of cable are drawn taut.

" Run ! " now rings out the sharp word of command. The rope crew shoot forward ; the machine, held fast from behind, groans under the strain.

¹ The English Instructions are :—" Walk—Run—Release."

“ Let go ! ”

Like an arrow from the bow, the bird flies forward and upward, while the crew collapses head over heels. And now the motorless plane circles proudly and majestically above our heads ; it rises, taking advantage of every breath of air.

Then the flyer makes a dash for the clouds, ascending by the aid of forces known only to himself ; he reverses almost exactly the procedure of the eagle when it swoops on its prey. Still circling, he attaches himself to the base of the cloud, beneath which he hangs as though held by some mysterious magnetic force. Over the countryside he drifts along with it ; then he drops again towards a hill that lies in his line of flight and sweeps onward in the air current thrown up by the slope.

Perhaps one of these dare-devils is not contented with soaring below the clouds ; he lets himself be drawn up into one of them and “ flies blind.” He is enveloped in a sea of whiteness ; before him, to right and left, above, below, everywhere is this thick whiteness. There is no fixed point in this infinity, but with every fibre of his body and mind he holds fast to the aerial current and so maintains his equilibrium, as he strains his ears to catch the least sound in the opaque mass.

On such occasions short flights seem endless, but suddenly light glimmers and grows until at last he is out in the sunshine. He is above the clouds.

White hills of heaven tower around him ; every now and then one of them leans forward and makes a grab for him. But, flying nearly 10,000 feet above the sea level, he beholds for the first time the wonder of the ocean of clouds, as seen from above.

But we must not let our enthusiasm run away with us. Soaring flight is a serious and important business, even though it originated in some sport-loving enthusiasts' desire to fly. To-day it has its practical side ; it teaches us (for the first time in the history of flying) to feel our way in the air in the truest sense of the word, indicates new possibilities in the technique of flying and enlarges our general knowledge and weather lore. It is the only means

4 KRONFELD ON GLIDING & SOARING

of imparting a thorough education in flying to the younger generation ; it is perhaps the finest of all sports and may afford valuable assistance to pilots of commercial and passenger aeroplanes whose daily work is so responsible and dangerous. Sufficient instance of this are to hand. Do you know the engine that never fails, the feed-pipe that never breaks, the oil pump that is never ill humoured ? I do not. I only know that once I was flying quite peacefully across country in a light motor-powered aeroplane, unaware of any impending danger. The breeze was strong, and my progress slow. Suddenly all was still, uncannily still, around me. The engine had gone on strike, and could not be persuaded to resume work. Beneath me were a river, steep banks, a wood. My kingdom for a suitable spot for a forced landing ! Far and wide no such place to be seen ! Like lightning, my thoughts flew backwards ; some three miles behind me I had passed a fair meadow on the bank of a stream, but it was impossible to reach it in a glide. Impossible ! No such word ! Was I not a soaring flyer ? Had I not already flown sixty miles without any engine ? True, I was then flying a fine, light, special machine, but surely this short stretch could be managed ! Where was the air current that might help me ? I did not need to seek long ; soaring flight experiences had passed into my flesh and blood. I looked for the slope that threw the wind upwards, found it, and the machine was supported ! I glided back to the landing place ; plane and pilot were saved.

My case ended well. Now let us look at one that ends badly. A young traffic pilot is flying with passengers in a heavy wind ; somewhere down on a hillside he spies a magnificent castle which he wants to point out to them. He drops down, proud and secure in the power of his mighty engine, drops towards the side of the hill where there is a down wind. The merest tyro at gliding would know the danger, our pilot does not. Or perhaps he knows but pays no attention to it, puts it out of his mind ; hitherto, his engine's reliability has lulled him into a sense of security. He curves ; the passengers are delighted to see the castle so close beneath them, almost close enough to touch. Then



1. AN EVENING FLIGHT OVER THE DUNES OF ROSSITTEN



2. A "ZÖGLING" STARTING OFF. NOTE THE STARTING CREW AND THE CAST-OFF STARTING ROPE IN THE FOREGROUND

the pilot desires to rise again, opens out his engine, but the plane refuses to climb. If only the engine will hold out, he prays ; it does so, and under any normal conditions all would be well. But the conditions are not normal ; unfavourable circumstances have combined against him. The over-loaded machine does not climb quickly enough ; a sudden gust hurls the down-wind at him.

The pilot tries to turn away from the hillside in a steep curve. Too late ! A wing grazes a tree : the aeroplane turns over : tree trunks splinter : a benzine tank bursts : flames leap high. . . . Four more names are added to the death-roll of the air.

A super-aeroplane carrying thirteen passengers runs into a goods truck. Six, perhaps three, feet more height would have been enough to save their lives, and those extra feet can nearly always be won by the man who has learned by soaring experience to take advantage of the natural forces of the air in case of need. I know a motor flyer who won races because, being also an expert soarer, he could make use of the wind currents, and so spare his engine and economize fuel.

I know another who took his engine-driven aeroplane more than three thousand feet higher while shortening his climbing time by nearly half, after learning to apply the knowledge gained in experimental gliding and soaring.

Now how comes it that certain men possess, as it were, a mysterious affinity with the forces of nature ? How did gliding and soaring flights come into vogue ? Who carries them out ? What is their future ?

These are questions that I once asked ; I could find no answer to them. The books written on the subject were bad, the results of studying them correspondingly so. One thing alone was clear : all the heroic pioneers of early engine-driven flight began with gliding. . . . Lilienthal, Wright, Mouillard, Chanute, to mention only a few of the best-known names. The triumphant engine-driven flying of to-day has been built up on foundations laid by motorless flying.

As I read on, I found explanations of "upwind," "down-wind," "gliding," "soaring" etc., all of them confusing and useless in practice.

6 KRONFELD ON GLIDING & SOARING

I made a bold resolution and got together what money I could, some of it by the sale of my beloved collapsible boat and camera. Then I packed my suitcase and set out for one of the three German Soaring Flight Schools then in existence to find the answers to my questions in practical experience. Thus I came to Rossitten, a poor fishing village in the north-east of Germany, not far from the old Russian (now Lithuanian) frontier. The surrounding country is a mere strip of duneland, a giant dam built of sand, dividing the waves of the sea from those of the Kurische Haff.

Why Rossitten? He who wants to soar must learn it from Nature and her children, the birds. When the birds of passage go yearly to the south, they make use of those air currents which men also need for soaring. The path of those wandering birds crosses the dunes of Rositten.

There is not much ceremony in our German flying camps. After a meal with thirty other young men from every corner of the land and a few moments' breathing space, we went out to our flying ground. We fetched our machines from the two great hangars, and under the direction of our flight instructors we made sure that everything was in order. Then in groups of ten we pulled the aircraft to "the hill," which, in this case, was a sandhill barely two hundred feet high. Having reached the top, each in turn seated himself in a machine for the first exercise, which was to try to keep it balanced on its middle skid with the wind at its side.

The beginners' machines, the "Zöglings," are practical contrivances for their purpose. They are simple, cheap, easy to repair, and can readily be managed at once, even by young and inexperienced pilots. The learner sits entirely unenclosed, on an airy perch where he can feel every breath of wind, and if he has to dismount hastily from his aerial steed, he need only unbuckle his safety belt and fly a long parabola into the soft sand.

As with engine-driven aeroplanes the steering is done with the right hand. Push the control lever, known as the "stick," forward, and at once the machine dips towards the ground; pull the stick towards you, and the machine rises

instantly ; press it to right or left, and the plane follows suit. This may seem easy, even taking into consideration the fact that lateral steering must also be done with the feet. In practice it is by no means so easy as you might think.

Most gliders and soarers are shot into the air by a rubber launching-rope. When this is released, every scrap of good advice that his teacher has ever given him goes clean out of the head of even the best and most stout-hearted beginner. "Move your stick gently," the instructor has told him, "and fly straight forward"; but who can remember that at the moment when he loses the solid earth from under him for the first time in his life. Although the height to which he rises is insignificant, it seems enormous, and he longs to get down again.

He pushes the stick—the least little fraction, as he thinks, but in reality far too much—and the ground rises up madly towards him. Terrified, he pulls the machine up again ; she rises a trifle, and suddenly her inmate sees only clouds and sky. Once again he pushes the stick too hard, and this time somewhat to one side, whereupon he finds himself performing incredible acrobatic feats and making the most amazing curves in the air. His progress is not unlike that of a sheet of paper caught by the wind and whirled hither and thither on incalculably erratic courses.

The first flights of most pupils proceed on these lines, although we generally start them off at a spot only slightly above the level of the plain. Spectators who watch them with both feet planted firmly on mother earth cannot understand how a normally level-headed pupil loses his entire presence of mind on his first flight, but if they would enter the machines, the reason would soon become clear to them. A sharp gust at the moment of starting, the momentum of the machine or a mistake with the stick may hurl the novice some twenty or thirty feet into the air, when his feelings will be somewhat similar to those which a man might experience if, when seated on a chair, he was lifted up and held out of a third-floor window. His discomfort is increased by the rush of the wind on his wings and in the bracing wires as well as by the pace at which the ground

8 KRONFELD ON GLIDING & SOARING

beneath him seems to race past. To preserve one's equanimity under such circumstances a certain degree of self-control is needed, which can only be acquired. Later you realize, of course, that everything is really far simpler than you at first imagined, that every movement has its good reason, that you must make such movements quite gently and coolly, and that the beginners' machine flies best when almost left to fly itself without too much interference from the stick.

When a pupil has progressed sufficiently to feel calm and safe (which generally happens, according to his temperament and aptitude, somewhere between his ninth and fifteenth start) he may try for the "A Badge." To gain this he must make a straight, even flight of thirty seconds duration.

After passing this first test all future soarers are filled with inordinate pride. Each sees himself already as a future "King of the Air," and his exaltation lasts until the young pilot or his machine is thrown out of balance by some unforeseen circumstance, when he makes a mistake with the stick and finds himself a few seconds later lying in the sand, while his comrades gather up the debris of his machine. Such "bump landings" are seldom dangerous, and, indeed, my long experience of such flight has convinced me that fewer accidents occur in gliding and soaring than in almost any other sport. But through such unforeseen occurrences every novice learns that he has still a long way to travel before he can attain full control of his machine. Promoted to the advanced group, he now practises simple right and left-hand turns.

A good exercise is to fly round the course flags. You start from the top of the dune, fly over the gentle west slope to a red flag which the instructor sticks in the sand, turn above it, set your course for the next flag, turn round it in the opposite direction and finally land at a third, which everyone delights to pull out of the ground with his skid if it can possibly be done.

The pupil is now permitted to start in a stronger breeze, and has prospects of passing his "B" test. This is the gliding test; as usual with all gliding flights, it starts at the top of a slope. The pupil must fly for a whole minute

and make good right and left curves around two turning points.

The passing of such a test was always fittingly celebrated, for we were a wild, gay lot of youngsters at Rossitten. If anyone had suggested we should sail across the ocean in the first handy fishing boat, we would have done it. We feared nothing—not even the village nightwatchman, much to that worthy's annoyance.

But for all our pranks we realized the value of the lessons that our experiences of soaring flight at Rossitten taught us. There we attained what we could have attained nowhere else, and with no further equipment than the pocket money we received from home and the boundless enthusiasm that inspired us all. We learnt to fly, to make our turns and to parry the blows of gusts, in short we acquired the first glimmerings of air-sense.

But however industriously we practised our flights, our theoretical and technical education was not forgotten. Machines that were damaged or smashed gave us opportunities to study the craft of repairing and rebuilding them in the workshop and familiarizing ourselves with the elaborate constructions of seemingly simple aircraft. Everyone did his share. One knew something of carpentering, another of tinsmith's work ; all were pressed into service and learnt something. And so a kind of workers' co-operative association developed ; one learned from another, and when amateur knowledge and skill failed, one of the trained artisans was called upon for advice and help.

All learnt how the simple school machine was constructed, and on their return home many built their own machines with money acquired by the sale of a typewriter or a camera, and taught their friends what they had learnt at the school.

We must not undervalue the significance of the work performed by these groups of enthusiastic young men. In this way the brothers Lilienthal built their first plane on one side of the ocean, as did also the two Wrights on the other. The aeroplane designer, Fokker, began in similar fashion in Mainz before the war.

It was their enthusiasm that enabled these men to overcome all difficulties. With wire, steel tubing and insulation

bands, Fokker constructed his first primitive aircraft. To-day his machines fly over the world on many air routes.

When engine-driven flight was restricted in Germany after the war, it was the students who first took up soaring flight. From cheap waste wood and their mothers' bed linen they built their earliest machines, thus taking the first steps on the path that led them to become experts in soaring flights and breakers of the world's records.

In the year 1923 such a soaring plane was built by Ferdinand Schulz, an elementary school teacher of East Prussia. Its fittings were mainly made of old tin cans, its spars were broomsticks, or at least so like broomsticks that this flying machine, the seat of which was fashioned from the lid of an old sugar box, was nicknamed "The Broomstick," but with it Ferdinand Schulz won his first world record on May 11th, 1924. In bitter cold, without gloves or woollen clothing, with both arms raised to hold the stick, Schulz remained in the air for eight hours thirty-two minutes and nine seconds. That was his first record but by no means his last.

A young joiner, Gottlob Espenlaub, also constructed his first plane from primitive materials. He was very poor and often hard put to it to earn his daily bread, but he starved grimly and successfully, begged where he could, personally and by letter, for contributions to his work, and laboured day and night till his machine was finished. At that time he had not yet learnt to fly, and one of his first machines was smashed to pieces for him by a pilot who made a bad landing. Espenlaub clenched his teeth and began again; he learned to fly himself, and made record flights in his own machines.

I could cite other soarers whose careers began in similar fashion. Many are now celebrated constructors, aeroplane manufacturers or pilots, and all are examples of what personal efforts, aided by enthusiasm and grit, can achieve in the field of flying.

All these facts were related to us by our instructors or famous soarers who visited us and inspired us by their examples.

Wet and stormy days were utilized for theoretical instruction; the principles of aircraft construction were explained

to us, and we learnt the meteorological laws that govern weather, clouds, winds and currents. But our chief interests were centred on the visible developments of gliding flight which might enable human beings to remain in the air for hours in comparatively simple flying machines.

What we learnt indoors, we soon found opportunity to put to the test in the open air. At Rossitten the wind sweeps across the bay ; the east slope of the dunes, with its gradient of less than thirty degrees, bars its progress and throws it upwards. This upwind, which is our chief need, is found wherever the wind's course is stayed by obstacles of any kind, such as dunes, hills, houses or trees. There are also thermal upwinds to be found above warm surfaces, such as sand, rocks or cornfields, while other upwinds occur under the great piles of clouds known as cumuli. An upwind also precedes every thunderstorm.

The beginner can only make use of those upwinds which are created by long chains of dunes. Flights are practised over the steep slopes so that the pupils may be prepared to make use of any easterly breeze that may spring up. One starts high up, and, flying over a sudden sharp dip in the ground, suddenly sees the waves of the bay breaking on to the sand two hundred feet below ; then one flies along the chain of dunes and eventually makes a clean, gentle landing on the shore, only a few feet from the surf of the waves.

But matters do not always work out according to plan. For some reason or other the flyer may make a failure of his turn, in which case the machine flies on out over the waters of the bay ; once more he tries to bring off the turn, but cannot succeed in getting his machine to obey him, On he glides, and when his last despairing efforts have failed, he has no alternative but to "take a bath," to the immense delight of his fellow-pupils who throng the shore. The waves surge high ; for a moment the machine is lost in white spray, but after a little while it can be seen peacefully floating beside its swimming pilot. A certificate of ability to swim is required of all Rossitten pupils, and the salvage of the machine, which breaks up in nine cases out of ten, develops into a general aquatic entertainment.

To obtain the full minute's flight required for the " B "

test, the candidate often finds it necessary to fly in the true sense of the word, or, as we say, to sail. This is no easy matter, as it implies power to do what the best flyers among the birds do ; crows, sparrows and many other birds are often outdone in flight by the airman, but the hawk and the eagle can remain circling in the air at the same height for hours. To imitate their feats the steadiest nerves and finest air-sense are needed, so that many who pass the gliding test will fail at the difficulties involved in further progress. The numbers of the band of pupils diminish steadily, but the zeal and tenacity of the survivors remain unshaken.

The second great task of the school is that of weeding out the failures ; out of thousands of young folk who visit it, the best select themselves in the most natural and simple fashion. The surviving group of candidates for the " C " test comprises the hardy souls who refuse to be deterred. Their willpower and enthusiasm were greater than that of their comrades, and they are also the most gifted flyers.

For me, as for so many others, the great moment arrived. Very early in the morning came the message : " Good soaring wind to-day." I was the only one left in Rossitten out of a large group of " C " candidates, and I had sworn not to give in when so near to the coveted goal. It was already icy cold ; the early Russian winter had spread over the land, while the surface of the bay was coated with a sheet of ice ten inches thick over an area of more than seventy miles long and thirty-five miles broad. The school was nearly snowed up ; the icy wind brought a temperature which was hardly endurable except in the immediate neighbourhood of the warm stove. But I was resolved that, in spite of these obstacles I would pass my " C " test that day.

Soon afterwards the machine stood on the sandhill (which was frozen as hard as stone) ready for the start. Once more I tested my steering gear ; the " tail crew " and the " launching crew " were in their places. " Pull out ! " I cried ; " Run ! " " Let go ! ", and with its customary jerk the plane began to move.

Already I am over the edge, I go into a turn and fly along

the slope. The upwind which hurls its icy blast against my face lifts the machine ; now I am high above the ridge and heading for the turning point. Once more I turn but the plane banks, or rather, as it seems to me, the world about me banks and the slope on my other side rushes up towards me. I take my good bird out of the turn and slide along the slope again. Nearly three hundred feet below me lie the piled-up ice-blocks on the strand. Soon I come to a place where a bend in the ridge draws the wind away from me too much and here again I must go into a turn ; once more the machine flies silently onward, rising and falling in the wind. This silence is broken by a soft humming in the wires near me, like the tones of an Aeolian harp in the wind. Another rounding turn is made ; gradually I feel freer ; I am able to look about me and espy, quite small and far away, the village of Rossitten. When the curve is complete I see the village of Pillkoppen and the sailing-sledges that glide along over the frozen surface, which is as clear as a mirror. Far below, the fishermen are busy drawing up the nets, which they let down through holes in the ice.

Hello ! What's that ? Down there on the hill I see all the folk standing in the queerest attitudes ; the launching crew are swinging their arms in the air and kicking up their legs. Seen from a distance they look like a flock of crows, but from their mouths issue the full-throated cry of the crane, the signal that the conditions of the " C " test have been fulfilled. I have soared for five minutes, I was continually above the height of the starting point, and I have flown my rounding turns correctly.

Shall I land now, after waiting so long for this flight ? No ! So I continue from turn to turn. I begin to count : one, two, three, four . . . fifty, fifty-one, fifty-two, and still it goes on ; I know that I am now making a rounding turn per minute. At last someone calls up to me, but I cannot hear his voice distinctly.

I had been flying for half an hour and—the thermometer registering, as I heard later, seven degrees below zero—I began to feel the cold creeping up my legs. The unprotected parts of my face were frostbitten; my left hand

grew stiff. I thought of landing but set my teeth ; Ferdinand Schulz, the East Prussian teacher, had stayed up for fourteen hours at just this place the previous summer. Of course, he had a much better machine, but I simply had to keep on, and so I stuck it. I thought of Max Kegel, the "Thunderstorm Max," who was caught unexpectedly by a thunder squall and, fighting continually against storm, cold, and clouds, soared to a height of six thousand feet ! And then I thought of the time when Ferdinand Schulz, with the aid of the upwind from the sea dam which is here hardly higher than a railway embankment, flew overland from Rossitten to Memel, a distance of thirty-six miles. After an hour and seventeen minutes I landed half frozen. This was my last flight in Rossitten.

He who has once known the joys of soaring can never abstain from them. In spring we all met again in the Rhön Mountains, where there was a training course. Old war pilots, air-mail pilots, young students and old school masters were all drawn by their common enthusiasm to this "Soaring University."

The school machine "Prüfling" hung over the western slope of the Wasserkuppe, three hundred and sixty feet above the starting place, a thousand above the valley. We flew for hours in the squalliest weather, made the steepest turns and landed at a speed of seventy miles.

A Norwegian Flight-Lieutenant was with us. In his own country he flew the finest aeroplanes, driven by engines of many hundred horse-power. When he first arrived, he looked with a friendly and somewhat condescending smile on everything that did not quiver and roar with motor-power. Then he made his first experiments in soaring, and as time passed he grew more and more appreciative. At last he passed his "C" test ; he was so delighted that he could hardly bring himself to land. And when he finally came to earth at a speed of seventy miles, with the wind behind him, he sprang from the machine crying : "I have never really flown till to-day !"

In the beginning we thought that air-sense was everything. Through our "C" test we had discovered how to estimate the strength of squalls in advance by the shape and nature

of the slopes, but here we learnt much about the currents that flung us up and down as well as ascertaining how to calculate the recurrence and velocity of the squalls we encountered. The ocean of air, which had seemed so formless and incomprehensible, began to take shape, because the element through which the flyer moves, and upon the properties of which he is so dependent, was bound to reveal its proportions to the man who sailed through it in a way that it could do to no other. We learnt how dependent we were on the gigantic energies of the aerial ocean and discerned that many accidents could be avoided by an accurate knowledge of the element in which we flew.

Thus Science was now added to sport and instruction in currents and weather lore, the two most important provinces of knowledge for the soarer. The technical side of flying has benefited greatly by our soaring experience, for it is well known that the light aeroplane which will popularize flying for the masses can only be developed from the data we supply. Messerschmidt, one of the best German aeroplane constructors, first found out how to build firmly yet lightly when soaring in the Rhön quite at the beginning of his career. His light motor plane was victorious in the Tour of Europe Flight.

The Klemm aeroplane, with only twenty horse-power, that completed a flight round the world, was directly modelled upon soaring plane building.

Here we see art rather than mere technique. The vital problem is to learn how to build lighter, firmer and cheaper machines. Already there exists a magic bird with which you can fly across country, fight the thunderstorm and defy the heaviest gales, but its wings span from fifty to sixty-five feet, and it weighs only from two hundred to three hundred pounds. It does not cost more than a Baby-Austin.

At first, at Rossitten, we paid little attention to the models we saw flying there. On the Wasserkuppe in the Rhön we all grew attentive when we saw the technical side of flying in actual operation. Models were first tried for gliding and subsequently devoted to soaring ; while we trained, various new aeroplane types were built as soaring machines. A " Duck " and a tailless plane soared on the western

declivity ; at a small cost all the flying peculiarities or specialities of these models could be tested in soarers. The little tailless plane developed a speed of over sixty miles an hour with a motor of only 8 h.p., and is surely a herald of the new type of aeroplane of the near future.

Science, flying technique and training are all united to find expression in this last and the greatest achievement. Racing flight demands flyers superior to all others, and machines that can beat their competitors as well as meteorological knowledge that embraces the least breath of air. Mutual assistance makes for progress ; the man of science helps the pilot, while the latter brings to the former new experience and problems. This is the spirit animating the Research Institution of the Rhön Rossitten Gesellschaft in Germany, which arranges the competitions in the Rhön. It watches over sport, training and research. Machines are constantly being improved, and pilots grow ever more sensitive and skilled, and thus we improve our knowledge in competitions which start from the hillside and continue in the clouds.

We fly over great stretches of land. Never shall I forget how I demonstrated for the first time the practicability of flying quite independently of slopes. I circled under the clouds at heights which had not previously been reached. Then I went in for a record. From the cloud to the slope, from the slope to the cloud, again and again, until I had flown a distance from point to point of more than sixty miles. Such cross-country long-distance flights are not mere sport like endurance flights. To carry such flights successfully through, one must be able to read weather charts, to recognize air currents, and to combine flying skill with nice judgment as to all the possibilities at a given moment.

The soaring flight movement goes forward as speedily as the wind that bears up the widespread pinions of its planes. He who will move with it, must hasten. Yesterday it was only a game, a sport ; to-day it has enlisted technique and science on its side ; and to-morrow everyone will have to recognize it as the basic principle of all flight.



3. THE "CHARLOTTE," A TAILLESS SOARER THAT TOOK PART IN THE RIÓN MEETING OF 1924



4. THE RHÖN-ROSSITTEN COMPANY'S TAILLESS SOARER, THE "STORCH," WHICH WAS GIVEN A LIGHT ENGINE FOR A SERIES OF EXPERIMENTS



5. THE COMPETITION IN 1920, FOR WHICH MANY HANGING GLIDERS WERE ENTERED

Facing page 17

THE HISTORY OF SOARING FLIGHT

THE legends concerning soaring flight take us back to the dim dawn of history. The myths of all religions teach us that before man came upon the earth the immortal gods existed from time immemorial. Winged angels were their messengers, and winged gods peopled both earth and heaven. The human race felt itself so inevitably fettered to earth that it could conceive of only a hierarchy of divine beings as powerful enough to soar free above the irresistible force of gravity.

From the beginning man has longed to fly. His longings are symbolized by the god-like beings clad in ethereal winged garments that we find as objects of worship in the religion of almost every human community. These represented man's earliest desires ; only later did he dare to imagine that he might one day fly himself.

A Babylonian work of art that was produced more than four thousand years ago shows us a certain Etana mounting to heaven to seek the aid of the sun-god. Borne aloft on an eagle, he looks down and sees all mankind carrying on its daily occupations. In the *Talmud* and in the fascinating *Arabian Nights* men sail through the air on flying horses and magic carpets ; the myths of the North American Indians have legends of heroes who clad themselves in the skins of great birds and soared above the earth. The South American tribes and the African negroes have similar folk-tales.

All over Northern Teutonic Europe we have various forms of the legend of Wieland, the smith, who made himself wings of the feathers of birds to escape from captivity, while the Finnish sagas relate of another wonder-working smith who fashioned a steel eagle.

“ Up he swings himself to the pinions ;
On the bird's back see him seated.
Then swiftly flieth the beauteous eagle,
Stateliest of all the birds of heaven.”

The greatest general of antiquity is also represented in art and legend as flying, for Alexander the Great is said to have harnessed to his chariot two winged dragons. His charioteer dangled before their eyes the carcass of a slaughtered animal, affixed to a long pole, so that the king was able to guide his strange steeds by manipulating the bait.

Then we have the Greek legend of Daedalus and his son, Icarus, which Virgil and Ovid retold in Rome. In order to escape from Minos, king of Crete, who imprisoned him in the labyrinth he had built for the monarch, Daedalus fashioned birdlike wings for himself and his son. But intoxicated by the joy of flight, Icarus soared too close to the sun, the warmth of which melted the wax that affixed his wings to his shoulders, and so he fell into the sea. The Greeks also gave us Phoebus Apollo, with the winged horses that drew his chariot, Perseus who wore the winged sandals of Hermes, and Bellerophon on his winged horse, Pegasus. In our northern climes the Valkyries flew through the air on winged steeds, and later the medieval witches on winged broomsticks.

But we must not linger in this fascinating realm of myth and saga, with its infinity of legends, for the stories of the early history of flight claim our attention.

Two thousand three hundred years have passed since Archytas of Tarentum, a pupil of the immortal Pythagoras, built an artificial bird. Later, in English chronicles we find an account of an attempt to fly, that must have been made about the time when Rome was founded. A mighty ruler, the father of King Lear, grappled with the truly royal problem and built a man-carrying airship in which he succeeded in soaring above his capital, Trinovantum. But one day it failed to maintain its balance and crashed down upon the temple, killing its pilot.

The same fate befell the mighty sorcerer, Simon Magus, Not contented with his fame, he thirsted for godlike honours and resolved to outdo all other human beings. He even attempted to convince the Emperor Nero of his Olympian mission by proclaiming that he would raise himself up to heaven from a Roman amphitheatre before the assembled

multitude. All Rome thronged to this unusual spectacle and, as the apocryphal legend tells us, Simon flew up on dragon's wings by the help of demons. But St. Peter sent up a prayer to Heaven, and the evil spirit was paralyzed. The magician fell, and his blood sprinkled the emperor's robe.

An English Benedictine monk was inspired by Ovid's description of the flight of Icarus to construct a flying machine with which he made many experiments. On one occasion he sprang from a tower, hoping to be sustained by a strong head wind that was blowing at the time, and must have actually flown a hundred feet or so before he fell and broke all his bones. In the twelfth century Constantinople was the scene of a similar attempt ; a Saracen who wished to prove himself a wizard donned a white mantle which he had stiffened with willow withes and leapt from a high tower whence he proposed to fly over the hippodrome. But he also fell and was dashed to pieces. Perhaps the greatest genius among the early experimenters was Leonardo da Vinci, the famous painter, sculptor and engineer, who made serious scientific attempts to solve the problem of flight about 1488 A.D. when he constructed out of stiffened linen a pair of wings which he modelled on the membranes of a bat. He made mathematical calculations and a number of sketches to demonstrate his ideas of the possibility of soaring in the wind, but as he came under suspicion of witchcraft he dared not carry out experiments in public. Consequently his intelligent researches, which under happier circumstances might have proved a basis for the development of flight, were wasted.

If we may believe the old chronicles, Dante of Perugia, the mathematician, was among the first to construct a real flying machine. He experimented with it above Lake Trasimeno, where he often succeeded in maintaining himself in the air for considerable periods. At the marriage feast of a celebrated general he sailed over the principal square of the town, where the crowd cheered him enthusiastically. "Suddenly the iron with which he steered his wings snapped; Dante fell upon the roof of St. Maurius' church and broke his leg."

It is, of course, not easy to separate the grain of truth in these stories from the heap of chaff under which an embellishing imagination has buried them. It is no wonder that people who witnessed the first attempts at flying should be carried away by such startling spectacles and sacrifice accuracy to poetic imagination in their accounts of them. But to-day, when we often see gliders capable of carrying men that have been put together out of laths and odd bits of wood spanned with paper or cheap material, it becomes easier to believe these stories.

But fantasy has its rightful place in the world. The poet is a guardian, who watches over a new idea, so that it shall not die. He fans to life the dying ashes of the human spirit until he has created a flame in which technical knowledge may forge discovery and progress.

From the legend of Simon Magus developed the Magus Saga, with its fantastic flight to Rome. We also see in the Dr. Faustus of the Middle Ages another personification of man's will to attain the airy path to heaven. But much time was yet to elapse before the aspiration could become reality.

Goethe's Faust addresses the setting sun as follows :

“ The glow retreats, done is the day of toil ;
 It yonder hastes, new fields of life exploring.
 Ah, that no wing can lift me from the soil,
 Upon its track to follow, follow soaring !
 Then would I see eternal Evening gild
 The silent world beneath me glowing,
 On fire each mountain peak, with peace each valley filled,
 The silver brook to golden rivers flowing.
 The mountain chain, with all its gorges deep,
 Would then no more impede my godlike motion ;
 And now before my eyes expands the ocean
 With all its bays, in shining sleep !
 Yet, finally, the weary god is sinking ;
 The new-born impulse fires my mind,—
 I hasten on, his beams eternal drinking,
 The day before me and the night behind,
 Above me heaven unfurled, the floor of waves beneath me,—

A glorious dream ! though now the glories fade.
 Alas ! The wings that lift the mind no aid
 Of wings to lift the body can bequeath me.
 Yet in each soul is born the pleasure
 Of yearning upward, onward and away,
 When o'er our heads, lost in the vaulted azure,
 The lark sends down his flickering lay,
 When over crags and pineclad highlands
 The poising eagle slowly soars,
 And over plans and lakes and islands
 The crane sails by to other shores."

Does not this sound like the despairing cry of mankind after thousands of years of patient waiting ? But a century after those lines were written man could fly. The poet's dream had become reality, and the reality was pure poetry.

The rapid, feverish, forward movement was followed by a reaction. For nearly two hundred years we hear of no further attempts to fly. It seems, however, that men were only waiting for the time to ripen, and the next to enter into this field of work was the ripe product of his time, perhaps even in advance of it.

"Sir George Cayley may be fairly described as the source of our knowledge of aerodynamic science." So says Bernard Weiss in his excellent book, *Gliding and Soaring Flight*. Cayley recognized that what was chiefly lacking in flying was some knowledge of the forces at work in moving air. He made the first efforts to understand and express the elementary principles of flight mathematically. He built a glider with a surface of three hundred square feet and which approached our modern principles of stability and of steering in many respects. To quote his own words, "When any person ran forward in it with his full speed, taking advantage of a gentle breeze in front, it would bear him up so strongly as scarcely to allow him to touch the ground, and would frequently lift him up and carry him several yards together." In the year 1810 he published his researches in a book written in such a comprehensive spirit that it is the first which may really be termed a scientific treatise on the subject. In this work he shows

himself fully a century ahead of his time. Had more attention been paid to it, the world would probably have achieved flight a generation earlier, thinks Weiss.

Cayley did not actually succeed in flying. The honour of the first authenticated flight falls to that practical experimenter, the French Captain Le Bris, an old sea bear who had sailed much in tropical waters, where he watched with admiration the flight of the great sea birds, especially that of the albatross on its outspread wings frequently spanning twelve feet from tip to tip.

The artificial albatross which Le Bris built had a span of forty-five feet and weighed a little over one hundred pounds. The flyer stood upright in it, and Le Bris had taken pains to reproduce his magnified bird in dimensions and weight corresponding proportionately to those of the original. The apparatus was suspended on a trolley, which was drawn rapidly against the wind by a horse, but on one occasion when the bird rose from its carriage and soared in the air its launching rope became twisted round the neck of the terrified driver and carried him along with it. It is stated that on this occasion Le Bris rose to some three hundred and fifty feet above the heads of the country people who were looking on.

In spite of a broken leg sustained in a fall Le Bris refused to abandon his experiments. In 1867 he built another albatross, for which he used a new launching apparatus, consisting of a rope hanging down from a gallows-like frame on which the imitation bird swung in the air like a pendulum. By artificial aid he contrived to set his apparatus oscillating against the wind, then at the right moment he pressed a lever which released the attachment and free gliding began. Unfortunately the intrepid flyer kept his technical methods secret, so that they were lost to posterity.

In 1864 a Frenchman named d'Esterno built a flying machine which was also the result of experience gained by a careful study of birds for many years.

But his work is insignificant compared with that of his fellow-countryman, Mouillard, whose name was almost unknown during his lifetime despite the fact that he devoted nearly thirty years to the problems of flight. After his

death, however, a complete collection of his notes, sketches and plans was discovered in a cellar of the French Consulate in Cairo, while his work, *L'Empire de l'Air*, shows a vast knowledge of the flight of birds which he studied in his Algerian home and later in Egypt.

He watched the flight of the great soarers of the air, such as the vulture and the eagle, while at sea his enthusiasm was aroused by the albatross and frigate bird. He observed the habits of all birds and noted them conscientiously, a matter which gave him special food for thought being the fact that eagles and vultures only flew when the wind velocity did not exceed twenty-six miles an hour and invariably sought shelter if the air-currents attained a greater speed. On the other hand the long narrow wings of graceful sea birds, such as the albatross and frigate bird, could fly in heavy gales with a wind velocity of more than fifty miles an hour. Inspired by these facts, Mouillard experimented in weights, spans, wing surfaces and velocities, not omitting to inquire into the functions of the tail feathers, of which most previous experimenters had acquired but little knowledge.

Mouillard built four machines, the third of which consisted of two boards to which were attached ribs of agave wood that radiated like the widespread fingers of a human hand. The fabric spanned across these wings formed a tailless plane that assumed more or less the shape of an eagle's outspread wing. The flyer stood upright in his apparatus, holding fast with both hands to strong straps attached under the wings. This glider weighed only thirty-three pounds.

Although Mouillard carried out his experiments on a lonely farm in Algeria he found himself exposed to the ridicule of his household unless he contrived to send all its members away every time that he brought his imitation bird out of the hiding place in which he had secreted it. At first Mouillard took off from only a slight elevation, but later he felt a desire to try his luck in a stronger breeze. When he did so, however, a gust caught him, threw him up thirty feet into the air and carried him back a hundred and thirty feet. It then dropped him very suddenly, so

that he was hurled over backwards, and in his fright he let go of the wings, which were smashed to fragments. He took the bad end of this experiment so much to heart that he abandoned all further efforts.

The most important thing in connection with his work was his enthusiasm, which was far greater than that shown by any of his predecessors. The brothers Wright were inspired by his words, which stimulated them to efforts that finally led to success. They said :

“ We believe firmly that in soaring, the ascent must be made only by skilfully taking advantage of the strength of the wind. The steering in every direction is the result of skilful manœuvring of such a kind that a man provided with a soarer without any motor power can, even in a moderate wind, raise himself into the air and move about in it as he wishes, even against the wind.”

TIME BRINGS THE ANSWER

FEW of the tasks which man has dared to attempt have demanded of him such stern endurance as the solution of the riddle of flight. Some experimenters made calculations, others built machines, a third group studied weights and dimensions. Many drew very near to the long sought goal of free flight ; some few actually contrived to rise into the air. But their successes were mainly achieved by unsystematic and unscientific guesswork until Otto Lilienthal laid the first stone of that strong foundation which supports the edifice of the science of flight of to-day. It is his spirit that inspires our young soarers to seek the training ground of the mountains, for we recognize by the achievements of his best pupils how strong his inspiration was. Let Wilbur Wright speak for him :

“ Herr Otto Lilienthal seems to have been the first man who really realized that balancing was the first instead of the last of the great problems in connection with human flight. He began where others left off, and thus saved the many thousands of dollars that it had theretofore been customary to spend in building and fitting expensive engines to machines which were uncontrollable when tried. He built a pair of wings of a size suitable to sustain his own weight, and made use of gravity as his motor. This motor not only cost him nothing to begin with, but it required no expensive fuel while in operation, and never had to be sent to the shop for repairs. It had one serious drawback, however, in that it always insisted on fixing the conditions under which it would work. These were, that the man should first betake himself and his machine to the top of a hill and fly with a downward as well as a forward motion. Unless these conditions were complied with, gravity served no better than a baulky horse—it would not work at all. Although Lilienthal must have thought the conditions were rather hard, he nevertheless accepted

them till something better should turn up ; and in this manner he made some two thousand flights, in a few cases landing at a point more than a thousand feet distant from his place of starting. Other men, no doubt, long before had thought of trying such a plan. Lilienthal not only thought but acted ; and, in so doing, probably made the greatest contribution to the solution of the flying problem that has ever been made by any one man. He demonstrated the feasibility of actual practice in the air, without which success is impossible. Herr Lilienthal was followed by Mr. Pilcher, a young English engineer, and by Mr. Chanute. A few others have built machines, but nearly all that is of real value is due to the experiments conducted under the direction of the three men just mentioned."

Wilbur Wright and his brother Orville certainly achieved world-renowned success, and we must not omit to record here the names of Herring in America, Ferber in France, and Etrich and Wels in Austria.

Otto Lilienthal was born on May 23rd, 1848, in a small German town, his family being descendants of old Swedish ancestors that had settled in Germany before the Reformation. His father was a tradesman ; after his early death a prudent mother brought up her children carefully and contrived by dint of hard work and strict economy to give both sons a high-school education. Otto soon showed technical talent, but, as is the case with many great men, his progress at school was mediocre. His special gift, however, began to develop in his fourteenth year, when he made himself a pair of artificial wings. It was a dangerous experiment. Though fearless of the risks he took in the air, he had hard work to face the teachers, who could not understand what they termed his "senseless whims," and the ridicule of fellow-pupils who loved an opportunity to jeer at him. Only in the privacy of moonlit nights could he find opportunity to test his wings and essay the first leaps into the air.

At sixteen, Lilienthal entered the Technical School at Potsdam, where he studied to become a sculptor. He was a diligent and eager pupil at first, but soon found his studies too unpractical for his liking and undertook voluntary



6. OTTO LILIENTHAL, THE "FATHER OF SOARING FLIGHT"

Facing page 26

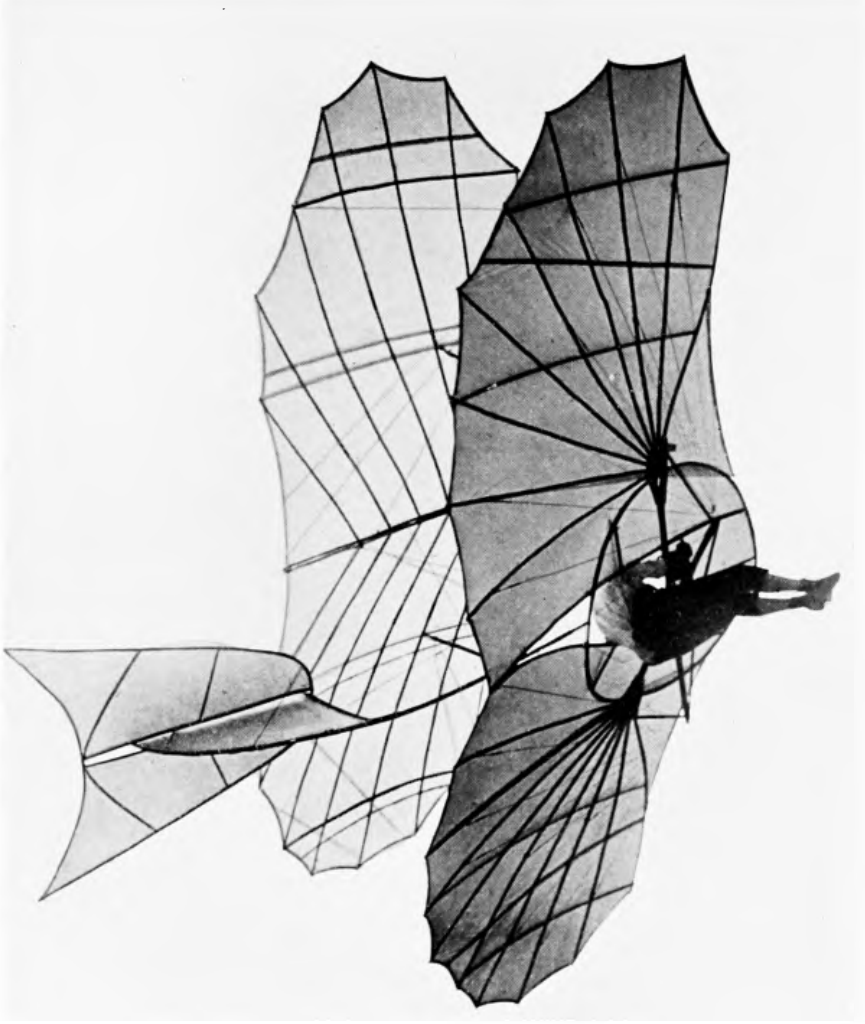

7. ONE OF THE NUMEROUS HANGING GLIDERS BUILT BY LILIENTHAL
After his initial experiments with single-decker gliders, Lilienthal
achieved better results with the double-decker type

work in a machine factory. His technical researches, however, nearly came to a disastrous end when an incubator that the brothers had made as a birthday present for their mother, took fire.

The young Lilienthal's thirst for knowledge was now awake, and at the age of nineteen he took up the study of mechanics. Money was scarce with the brothers, but they held faithfully to one another and made a special study of the art of living without meals. They shared the home of a cab-driver . . . and starved and saved.

During this time their flying aspirations were not forgotten, but for all their pains they made little progress. They could not succeed in rising by means of wings that beat the air, and found that the measurements and researches of others, upon whose work they depended, were incorrect. And yet Lilienthal's motto was : "The art of flying cannot and must not be for ever withheld from mankind."

Their ambitions came into conflict with the struggle for daily bread. When he was twenty-one, Otto obtained permission from the Berlin police to put on the streets of Berlin a vehicle which he had invented, and which a man could propel by means of pedals, but the financial success which he expected from it did not materialize, as the experimental model could only be forced along the rough roads with great exertions. The rent of the shed in which it was stored proved too much for the brothers' resources, so that it had to be sold cheaply, but in his fight for existence Lilienthal developed into a versatile genius. He constructed mining machinery, naval signals, and patented a box of toy bricks for children, which won popularity. In 1886 he invented a steam boiler which bears his name to this day. He even became the owner and manager of a theatre, and in his attempt to promote cheap drama for the masses he added to his experiences that of bankruptcy. He patented a reading game, a reckoning machine and a safety screw. Whoever thought that life and hunger could defeat Otto was greatly mistaken ; the patent for a belt pulley at last brought purchasers and money ; the years went by, and at forty-three Lilienthal had at last reached a point where he could have settled down to enjoy

life as a good citizen, a manufacturer and the father of a family.

But he was still under the spell of the ideas that inspired him as a schoolboy, thirty-two years previously. In 1892 Lilienthal returned with all the old enthusiasm (and now armed with technical knowledge) to his favourite hobby to which he sacrificed all his hard-won gains.

In the garden of his house he had a spring-board, three feet high, put up on the lawn, from which he took off in his first machine and only after he had acquired knowledge through hundreds of trials did he raise this starting point gradually to over six feet. From that height he contrived to float safely over the whole lawn.

The gliding machine he used was tailless. It had a surface measurement of fifty square feet and weighed forty-four pounds. It resembled the outspread wings of a bat, the flyer hanging free in the middle with his outstretched arms resting on two cushioned supports attached to the frame. The hands gripped the cross bars. When he was in the air, he stretched his legs to left and right, moving them backwards and forwards, and skilfully shifting his body's position. By thus changing the centre of gravity he contrived to keep himself and the machine always in the right position. He could fly quite well, when there was no wind, but if a breeze sprang up, the neighbouring houses caused too many eddies. Consequently the eager engineer removed to a lonelier spot.

The first series of carefully planned gliding experiments was concluded. Lilienthal now recognized that he could gain speed and make better landings by flying in stronger wind. From a knoll thirty feet high he succeeded in flying two hundred and forty feet—eight times the distance of the height of his starting point.

Even the lack of suitable elevations near Berlin did not trouble him. Two years after the commencement of his first experiments he built a shed on a hillock, but was compelled to construct a machine that could be dismantled for transport and housing purposes.

Lilienthal now combined the results of all his experiences in the big new machine, with which he flew from the top of

a hill of between two hundred and two hundred and fifty feet high near Rathenow. Its surface measurement was a hundred and fifty square feet, and he started in the simplest way by running with his apparatus against the wind ; when the wings were moved quickly enough they began to carry him ; he rose into the air, and gliding began. Although he went to work, as he tells us himself, with the utmost caution, accidents sometimes occurred. From a fatal end to one of them he was saved by the stabilizing effect of a tail which he had just added to the machine. It is amazing that he never lost his gift of calm observation, even in the most difficult situations, and he was therefore able to record the following impressions :

“ Once, on a soaring flight which I started from a greater height my body and outstretched arms fell into a position in which the centre of gravity was shifted too far back, and I was so exhausted that it was impossible for me to bring my arms forward again. As I sailed along at a height of sixty-five feet and a speed of about fifty k.p.h. the apparatus, which was heavily weighted behind, tipped up more and more, and at last (owing to its motive power) shot up vertically into the air. Desperately I held fast, seeing only the blue sky flecked with white clouds, and expecting from moment to moment that the machine would turn over backwards and end my soaring experiments, perhaps for ever. Suddenly, however, it ceased climbing and began to drop backwards ; it was steered into short circling curves by the horizontal tail which was now slanted upwards, until it turned over so far that it stood on its head and plunged down with me perpendicularly earthwards from a height of sixty-five feet. Fully conscious, with arms and head forward, still holding fast to the machine, I fell towards the green grass. A jolt, a cracking, and I lay with my glider on the ground. The only bad results of this accident were a flesh wound on the left side of my head, which I had knocked against the framework, and a sprained left wrist. The glider, remarkable as it may seem, was quite undamaged. Both the machine and I had been saved by the elastic buffer which, as though guided by a special Providence, I had recently attached to the front of the machine. This

buffer, which was made of willow, was smashed to bits, single pieces of it being driven a foot deep into the ground, so that they could only be extracted with difficulty."

By many tests and trials Lilienthal acquired much knowledge.

He had put his whole fortune and much labour into his work ; he had an artificial hill fifty feet high constructed, which cost him over £250 in wages alone. There he tried out his first biplane, on which he had been systematically working for some time, having previously tested its possibilities with a series of paper models, and his patience was richly rewarded, for the stability of this new type proved excellent.

It was wonderful how at the age of fifty, Lilienthal continued to build new flying machines with undiminished enthusiasm. In 1889 he published a book entitled *Bird Flight as the Foundation of Aeronautics*, in which, after recording his observations of the birds he had watched in the air, he proceeded to narrate his own experiences. He constructed several apparatus on which he experimented with different types of surfaces, and as the result of exact calculations he came to recognize the vital importance of the thick, curved wings that are in general use to-day.

No one who studies the book in which he describes his experiments can fail to be surprised at the success he built up from such slender foundations. He gives expression to the idea that inspired him in a poem, in which a stork addresses mankind :

“ But if you desire, like us in the flow
Of wind currents floating, the rapture to know
Of flight in air’s wide dominions,
Scan the build of our wings, measure our might,
Learn the air pressure that lifts us in flight
And thus study the work of our pinions.
Then try to discover the forces that bear,
When our pinions are beating intangible air,
On the long steady flight when we wander.
In us you will study creation’s intent,
And into your souls may knowledge be sent
To solve the hard riddle you ponder.”

Not only did Lilienthal gain knowledge to solve the riddle ; he acted upon it. With machines far inferior to ours he accomplished far more than we require from the candidates for the Beginners' Gliding Examination of to-day. On the Rhinow Hills he carried out flights of as much as a thousand feet, and frequently rose above his starting point. At the time of his most perfect flying he simply let himself be lifted from his hill-top by a strong breeze, and at the highest point of his undulatory flight he remained hovering for a considerable time, so that, while in the air, he could shout instructions to photographers below about the best positions in which to take him.

“ All the time I felt quite surely that I could fly farther if I inclined a little to one side, made a circular movement or let myself be driven by the wind. The wind itself had the tendency to produce these movements, so that my chief task in the air was to prevent myself from being swung round to right or left, for I knew that the hill from which I had started lay behind and beneath me, and that I could very easily come into disagreeable contact with it if I tried to circle.”

The father of soaring could also depict the beauties of his flights in glowing words that carried his readers with him :

“ It is difficult to convey to those who have never tried this kind of gliding any true idea of the fascination of its swaying motion. The depths over which you swing lose their terrors when you know from experience how safely you may rely upon the supporting power of the air. The gradual climb of these ascents into the air accustoms the eye to a correct view of the landscape which lies beneath. That uncomfortable feeling which assails the climber who places his foot in slippery ice steps on a narrow mountain ridge or on the scree above some yawning abyss often mars the enjoyment of a glorious view, for he knows himself beset by many perils lurking about him, any of which might lead to fatal results. The discomforts of vertigo do not oppress the flyer who trusts himself entirely to the air, which proves itself our bearing force, because it not only separates us from the abyss but supports us when we hover above it. He who soars on his broad pinions,

removed from contact with anything but air, propelled only by the breeze which, obeying the slightest pressure, lends itself to his will, soon loses all thought of danger in a wonderful feeling of security. . . . And such a soaring motion is a rich reward for all the trouble of attaining the necessary skill, for it is an indescribable pleasure to be rocked high in the air above the sunny hillsides, free from crowds, free from noise, lulled only by the soft music, like that of an Aeolian harp, which the breeze draws from the wires of the machine."

More than a thousand gliding flights had been carried out successfully when, on August 19th, 1896, the catastrophe occurred in the lonely Rhinow Hills that snatched away this heroic pioneer of flying from his work. He wanted to test a motor plane which he had built himself. As the benzine motor was still too heavy, the machine was to be driven by compressed carbonic acid. No one knows exactly what happened. The single spectator, Lilienthal's old assistant, only saw the apparatus suddenly heel over in the air and crash to earth with its pilot. It is believed that some error in the new method of construction rather than any mistake on the part of the pilot was the cause of this tragic end.

The day after the fall Otto Lilienthal died from his serious injuries. His whole life had been lived in the spirit of his last words : " Sacrifices must be made."

In Lichterfelde, a suburb of Berlin, where the intrepid apostle of soaring made his first flight, in his own garden, a monument is erected to the memory of this heavenward striving man. Upon it are engraved Leonardo da Vinci's prophetic words :

"The great artificial bird will some day set out upon its first flight from the summit of a hill. It will fill the universe with amazement and all books with its fame. And the nest where the bird was born shall be glorious for ever."

SPEEDIER PROGRESS

IN the history of flying we find that the deterrent effect produced by the sacrifice made by one man for the common good is only an apparent one. In reality the valiant, resolute spirit of humanity says : “ Now less than ever will we yield.” Consequently those who followed Lilienthal put all their strength and energy into the work they did.

Percy Pilcher, who may be rightly termed a direct follower of Lilienthal, was an engineer and a lecturer at Glasgow University. In 1895 he built a machine from his own designs, which show that he took pains to follow in Lilienthal's steps. He had endeavoured to acquire a correct conception of the machines and methods of his great teacher from reports appearing in newspapers and journals that were often exaggerated and incorrect.

His first apparatus had a surface of one hundred and fifty square feet and weighed fifty-five pounds, but his experiments made little progress. At last, however, he set out for Germany and visited Lilienthal in his workshop. In the master's well-developed machine he made several gliding flights and waxed enthusiastic over what he saw and learnt.

When he returned home, he set to work with renewed energy, and on one of his first efforts he was lifted by an upward gust to a height of twelve feet above his starting point and remained twenty seconds in the air. He subsequently carried out numerous gliding flights, in which he covered distances of from fifty to four hundred feet after launching himself into the air from heights varying from seven to twenty feet. But his machine was too light of build, and its wings were frequently damaged in rough landings.

He therefore constructed a stronger machine, but its steering gave him trouble, though he was the first to

recognize that it is not advisable to place the weight of the flyer too far below the bearing surface of the planes. His most successful machine was his fourth and last, which he proudly named "The Hawk." This beautiful apparatus contained various improvements, and its vertical supports were furnished with small wheels that facilitated his starts and rendered the landings far less dangerous for the pilot's body, which in Lilienthal's machines had to perform the work done by a modern aeroplane's undercarriage.

His starting method was new. A rope running over a pulley was attached to the machine and drawn by a horse or a crew of men, so that a quick run gave the machine an impetus which enabled it to rise into the air like a kite. As soon as the machine was fairly started, the connection was severed and gliding began.

To-day we should describe this machine as a braced monoplane. But in spite of his numerous improvements Pilcher still retained Lilienthal's method of steering by shifting the weight of his body. In this art, which demanded the muscular strength of a professional acrobat for its accomplishment, Pilcher attained such a high degree of skill that he remained immune from accidents until the fatal one which occasioned his death. This occurred through no fault of his own.

He had calculated that with the aid of a two-horse power engine he could remain indefinitely in the air, and constructed a light benzine motor which was estimated to produce four horse power. But before he was able to test this machine he followed Lilienthal to a flyer's death.

In 1899 he was anxious to exhibit the flying machine with which he had already made so many flights to the members of the English Aeronautical Society. He was flying at a height of about thirty feet above the ground when a bracing wire connecting a plane with the tail broke ; the machine fell before the eyes of the horrified spectators, and Pilcher crashed from this comparatively slight elevation so disastrously that he died of his injuries.

Pilcher's death evoked in England the same obstinate enthusiasm as Lilienthal's in Germany.

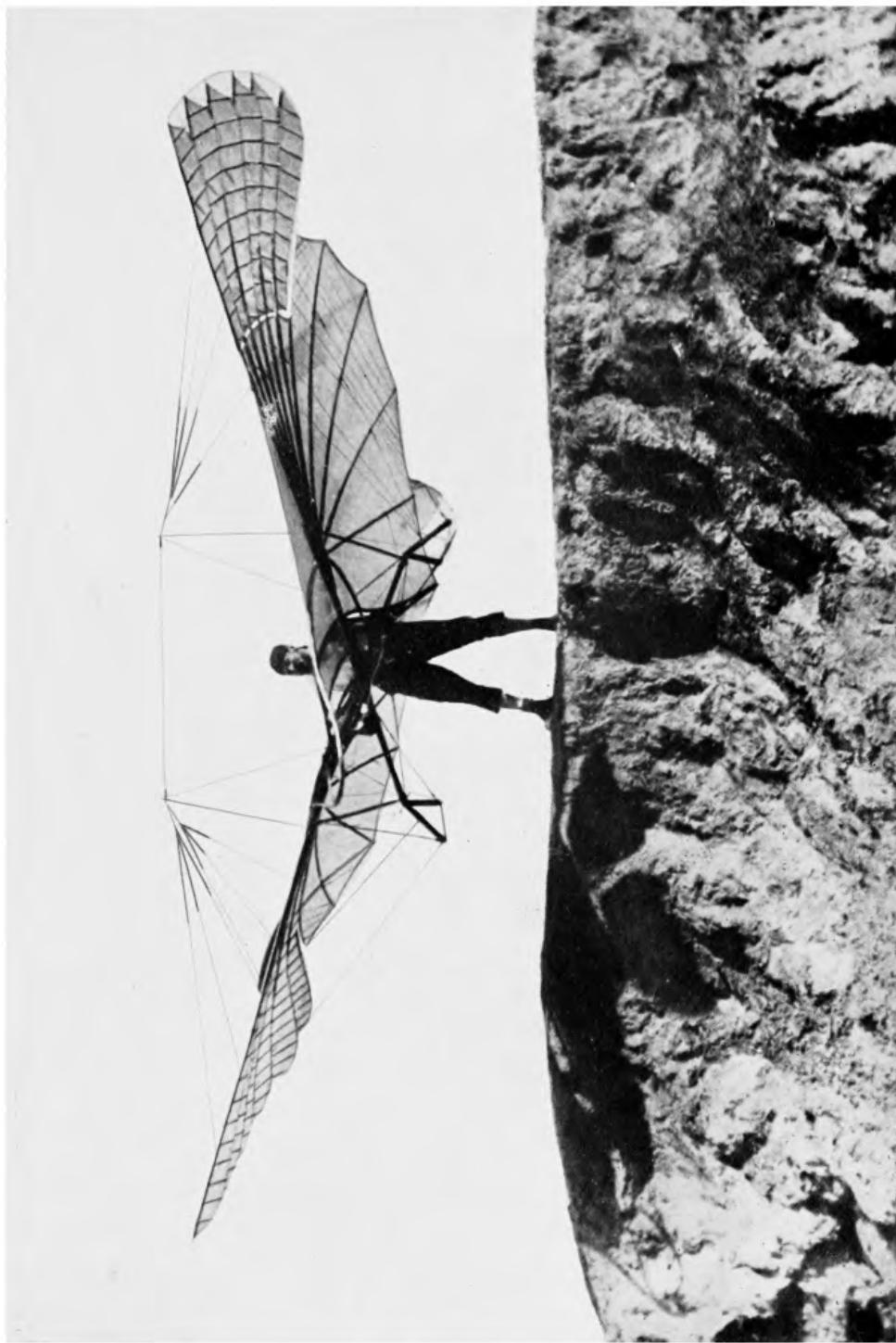

8. OTTO LILIENTHAL'S LAST MACHINE, IN WHICH HE CRASHED TO HIS DEATH IN 1896
It is curious to note that the pioneer of soaring flight met his end in the first machine he
equipped with an engine that was driven by liquid carbonic acid



9. A WRIGHT GLIDER OF 1902. ONE OF THE MACHINES IN WHICH THE BROTHERS WRIGHT CARRIED OUT THEIR SUCCESSFUL SERIES OF EXPERIMENTS

The development of aviation now became the common task of all mankind, instead of devolving on a few individuals. All over the world men took up the work of their predecessors in other lands and strove to carry it a step further towards the common goal.

From the vantage point gained by the experiments of Lilienthal and Pilcher, Octave Chanute initiated experiments in America in original and independent directions, and constructed a number of gliders. He had followed with interest the accounts given in American papers of Lilienthal's flights, and as a youth he had studied with avidity all contemporary works on the problems of flight. He undoubtedly derived much inspiration from Mouillard's *L'Empire de l'Air*, and in his own work, *Progress in Flying*, which appeared in 1893, he was the first to do justice to the efforts of the French pioneer.

He set to work scientifically. As a professional engineer—he was one of the best railway engineers of his time—he took the point of view that he could only learn from the failures of others, and therefore studied all the attempts made to imitate the flight of birds during the previous centuries, reconstructing each case and endeavouring to obtain a clear idea of the typical errors of every experimenter.

From the result of his investigations he deduced that the most important problem was that of stability. While fully appreciating their personal courage, he realized how primitive were the methods of Lilienthal and Pilcher, who had used their own bodies as counterweights to the forces of Nature. It seemed to him far more reasonable to achieve stability by means of movable planes.

Under Lilienthal's system the pilot submitted himself to the whims of natural forces, but Chanute set out with the assumption that it was necessary to compel those forces to serve man's will.

In his work he was assisted by A. M. Herring, a civil and mechanical engineer who had already made experiments of his own for some years previously. After testing several models they constructed their first glider, the "Ladder Kite," so called on account of its peculiar shape, a machine which made several good flights. But before

embarking upon researches into the realm of the unknown they desired to make further experiments on familiar ground ; Herring therefore constructed a model of Lilienthal's glider, with which and the "Ladder Kite" they undertook a series of tests in June, 1896, among the sandhills of Lake Michigan near Chicago. First the Lilienthal was tested ; then Chanute and his assistants proceeded to a number of original experiments.

They made trials with the most varied types of machines, some of which displayed extraordinary eccentricities of form, though all bore signs of the remarkable technical talent of their gifted constructor. One of these machines had six pairs of wings.

The best results were obtained from a biplane model, spanned with bracing wires. The wings were curved to precisely the same angle which Lilienthal had discovered to be the most favourable. The apparatus had an horizontal and a vertical rudder on the tail. Its stability was so good that the pilot only needed to move from two to three inches to maintain his equilibrium.

After numerous trials, all systematically and scientifically carried out, and all of which demonstrated the suitability of movable wings, Chanute summarized his experiences. He was firmly convinced that men would some day succeed in flying like birds, but not until the problem of automatic stability was solved. The present need was for a flying machine of such light build and so easily navigable that the personal strength of the steerer would suffice to control it in wind. Chanute recognized the great advantage of experimenting machines of the simplest type that could carry a man, and thus he was able to verify and extend his observations step by step.

Herring did his share by increasing the contemporary knowledge of stability and the interplay of aerial forces on a machine's wings.

Chanute and Herring were equally enthusiastic about flying, and maintained that gliding was superior to any sport then known.

Herring's share was mainly the whole-hearted support he gave to Chanute's work, and when the latter, owing to

his advanced age, could no longer take an active part in the tests, Herring conducted most of their practical experiments.

In addition to this Herring followed special paths of his own which led him to concentrate more and more upon the construction of a power-driven plane, and in 1896 and 1897 he published an account of his rich practical and theoretical experience.

We now reach a period in which it is hard to distinguish between the development of motor and soaring flight. An interesting example of this difficulty is the work done by Langley.

Professor Samuel Pierpoint Langley was an American astronomer and physicist. In 1886 he diverted all his energies to a study of the technique of flight, and five years later published his book, *Experiments in Aerodynamics*. He conducted his investigations in masterly and model fashion, as is shown by the revolving apparatus which he invented. It had a diameter of sixty feet, and to its arms small experimental planes were attached.

Langley measured the wind resistance of different plates at various speeds. He observed that the resistance varied according to the angle at which the surface was propelled through the air. He also measured the falling speed of plates upon stationary and rotating apparatus, and found that the results were quite different for long, narrow and short, broad surfaces. Two surfaces imposed above one another behaved quite differently in an air current to those placed side by side.

In a word, Langley weighed and measured everything that possibly could be weighed and measured. He was the first expert in aerodynamics in the modern sense of the word. In 1893 he published his *The Internal Work of the Wind*, in which he propounded that the wind is not, as was commonly supposed, a homogeneous stream with a more or less uniform velocity.

His investigations showed that not even the tiniest particle of air in motion pursued a steady course, as there were continual agitations, upward and downward expansions, whirls, backward and forward thrusts, all of which were

independent of the general movement. This was the internal work of the wind.

Later Langley built flying models, but always propelled them by motor power.

Langley's chief merit lay in his researches. He raised the work of the experimenter in flying to the rank of a science.

Two other men of whom far too little has been heard, Professor J. J. Montgomery as constructor and Daniel Malony as pilot, were the next to carry on in America the work of experimenting with airplanes that could carry a man.

The best machine built by Montgomery was a single-decker tandem based on one of Langley's models. The pilot's seat was in the framework between the two mighty wings, which were placed one behind the other, and there was also a tail with horizontal and vertical steering surfaces. But the great novelty on this plane was the device by which the curves of the plane could be varied to modify their buoyancy.

Montgomery carried out a whole series of single-handed experiments. The problems of balance and steering seemed to him still unsolved, and he reserved the problem of actual flying for later tests.

In the midst of his work he was debarred from further practical experiments by an injury to his leg, and in order to complete it he gave instruction in gliding to several men who were interested in his experiments. He may thus be said to have founded the first school of gliding.

Montgomery's best pilot was Maloney, who made a daring experiment in 1905. He had his flying machine carried up to a height of four thousand feet by a balloon inflated with hot air, and after cutting the connecting rope was able to test the possibilities of steering and various evolutions in his subsequent glide to earth. It is reported that Maloney flew in spirals and circles and could shoot forward as rapidly as the wind and then stand almost still, also seemingly against the wind. With amazement the spectators followed his movements from the ground; by means of the variable curves of his planes he was able

to perform such remarkable evolutions that the people safe upon the solid earth felt their hair stand up on end. But his most wonderful feats were his landings, which he accomplished with such ease and grace that they seemed to be attended with no difficulties whatsoever.

In order to truly appreciate the boldness of such flights we must put ourselves back into the spirit of that time. We may confidently state that Maloney's courage as a soarer has not been surpassed to this day.

The greatest success is often only separated by a hair's-breadth from the greatest danger. At the beginning of one of his ascents a rope from the balloon caught in the framework of his machine. Maloney did not notice it, started as usual and crashed. The impact was not very severe but he was picked up unconscious and died later, apparently from heart failure, as no serious injuries were discovered.

Montgomery, too, was the victim of an accident. One day he was caught by a wind eddy ; the steering gear of the apparatus was not sufficiently powerful, and the plane was dashed violently to earth. His injuries did not seem serious at first, but they proved severe enough to end his productive life.

THE WRIGHTS

IT now becomes impossible to follow the development of gliding and soaring chronologically. Every country was at work ; all over the world construction, flying, testing were going on simultaneously. We will first consider the activities of some men who saw their results.

As the brothers Wright themselves inform us, their interest in the problem of flight was stimulated when they learnt of the death of Lilienthal in 1896. As children little Wilbur and his brother Orville had played at flying ; they were fond of their kites, and still more so of a little screw-plane which their father, Bishop Molton Wright, once brought home to them from a journey.

Lilienthal's fatal accident reawakened the slumbering idea. All sorts of books were sought and studied, especially the works of Chanute, Langley, Lilienthal and Mouillard. "Mouillard and Lilienthal, the great missionaries of the flying cause, inspired us with their own unquenchable enthusiasm and transformed idle curiosity into the active zeal of workers." There were at that time two directions in which flying was developing. Professor Langley was building his steam-driven models, while in England Sir Hiram Maxim constructed at enormous expense (he probably spent about £9,000) a large, carefully designed machine driven by steam. This, however, was damaged in its first trial and never really flew.

The other direction was that represented by Lilienthal, Mouillard and Chanute. "Our sympathies were with the latter school, partly from impatience at the wasteful extravagance of mounting delicate and costly machinery on wings which no one knew how to manage, and partly, no doubt, from the extraordinary charm and enthusiasm with which the apostles of soaring flight set forth the beauties of sailing through the air on fixed wings, deriving the motive power from the wind itself."

The Wrights calculated that in five years of laborious endeavour Lilienthal only spent five actual hours in the air, but they were surprised that he attained such results with, relatively, so little practice. Thereupon the brothers took in hand the construction of a flying machine which was to develop only a low degree of speed, as it was their intention to fly it against a wind of its own velocity. In this way they believed that they would be able, while hovering over one spot, to remain in the air for long periods easily and safely. To produce such a machine they found it necessary to increase the area of their planes considerably, and they therefore did not deem it feasible to steer by shifting the centre of gravity as Lilienthal and Chanute had done. A movable elevator was attached in front of the double deck surfaces, while lateral balance was obtained by manipulating the wing tips.

In the summer of 1900 they began practical experiments at Kitty Hawk in North Carolina. They first sent up the machine as a kite, in which fashion it could lift a man with the aid of a stiff breeze. All sorts of experiments were made, and it was clearly shown that a variable curvature of the wing tips was far more effective than shifting the centre of gravity by body movements.

Soon the eager experimenters were ready for gliding trials. For this purpose they moved farther south where higher sandhills were more suitable for such flights.

It was not easy. Unlike their predecessors, the Wrights lay prone upon the surface of their machine. In order to start they had to run and then jump on to the machine as it rose ; when they landed, their legs had to take the shock.

The long flights for which they hoped were reduced to periods of two minutes, but they were well satisfied when they concluded their first trials, especially as they achieved a more perfect control over the machine than they had expected.

In the summer of 1901 they went again to their southern camp of Kill Devil with a new plane. It was bigger than the first, having a surface of three hundred and eight square feet, being, in fact, the largest gliding plane that had been built till then. The span of the great double decks was

twenty-two feet, the length fourteen and the height six.

With them went various people who were interested in the experiments, including Chanute, so that there was quite a little flying camp among the dunes.

The 1901 experiments were anything but hopeful, the only person to praise and encourage them being Chanute. Their machine would not soar, and so the Wrights had to rest content with their conviction, deduced from numerous gliding flights, that apparently all the measurements of their predecessors were inaccurate. At least correct measurements were so mixed up with incorrect ones that it seemed better to begin again from the beginning.

“We had taken up aeronautics merely as a sport. We reluctantly entered upon the scientific side of it, but soon found the work so fascinating that we were drawn into it deeper and deeper.”

So they set to work eagerly on laboratory experiments of their own, calculating the buoyancy of various kinds of surfaces. According to the experience thus gained a new plane was designed, and once again they went to the camp at Kill Devil.

The new biplane of 1902 had a surface measurement of three hundred and five square feet, and its weight without a pilot was one hundred and sixteen and a half pounds. It was so well built that it could withstand even bumpy landings, and carried out many gliding flights without suffering from wear and tear. Landing methods were now changed; the pilot remained prone in the machine while two skids broke the shock of contact with the ground.

The highest point on Big Hill lay a hundred feet above the level ground. According to wind conditions and other circumstances trial flights were carried on from this or various lower points.

In September and October of 1902 the results obtained were highly satisfactory. Many flights extended more than six hundred feet, and some were accomplished against a wind velocity of thirty-six miles an hour, a sign of the excellent control the Wrights had over their new airplane.

Constantly helped and encouraged by Chanute's advice,

the brothers made steady progress. They had recognized that true soaring demanded not only better machines but also better trained pilots. The Wrights still interpreted the word "soaring" as the power to maintain a position in the air above one spot. Often they succeeded in doing so for a time, and they also knew the difference, not yet clear to many even to-day, between soaring and gliding. They said: "In principle soaring is exactly equivalent to gliding, the practical difference being that in the one case the wind moves with an upward trend against a motionless surface, while in the other the surface moves with a downward trend against motionless air."

The only difference between this and our present conception of soaring is that now we not only hover in the wind, but can even make headway against it and climb.

In the autumn of 1903 the Wrights had achieved flights of more than a minute's duration. Often the plane hovered calmly above the same spot so that an onlooker ignorant of its nature might have thought that it only needed feathers on its wings to fly like a bird.

By this time they had accumulated a mass of material for their calculations, and the problem of balancing in steady as well as in gusty winds was practically solved.

The further work of the Wrights belongs to the history of motor flying. Through them the great importance of soaring and gliding had been demonstrated for the first time, and the addition of a motor was a step towards perfection. The way of experiment and apprenticeship in gliding flight had been a long one, but it was a silent and almost invisible herald of the victorious career of motor-aided flight.

Although, yielding to the spirit of their time, the Wrights devoted themselves later entirely to motor flying, they were nevertheless the first to realize fully what might be achieved by means of soaring. They were convinced that men would one day be able to build themselves wings which would surpass those of even the best soarers among the birds.

"However, when gliding operators have attained greater skill, they can, with comparative safety, maintain themselves in the air for hours at a time in this way, and thus by

constant practice so increase their knowledge and skill that they can rise into the higher air and search out the currents which enable the soaring birds to transport themselves to any desired point by first rising in a circle and then sailing off at a descending angle."

In spite of the brilliant progress made by motor flight Orville Wright tried his luck still once more, on October 24th, 1911, among the sandhills of North Carolina. He succeeded in remaining in the air for nine minutes and forty-five seconds, after which he was forced to descend because the contours of the dunes cut off his breeze. This was the brothers' last experiment in motorless flight.

Thus it came about that ten years were to elapse before the Wrights' record was to be beaten by a flight started on the German mountain known as the "Wasserkuppe."

FAMOUS CONTEMPORARIES

OTHER men were also doing good work at the same time as these brilliant, world-famed "Flight Kings." Lilienthal's influence on America had been an intellectual one, for the Wrights, Chanute and Herring all united to honour him. Meanwhile in Austria the traditions of the old master were being carried on ; in 1897 Nimführ acquired from Lilienthal's heirs his glider with movable wings and brought it to Vienna, and a year later a Berlin lawyer sold one of Lilienthal's original gliders to Igo Etrich, a manufacturer. Etrich and his father were regarded as visionaries by their contemporaries because of their interest in the problems of flight.

Nimführ's Lilienthal machine proved too worn out for safe use, but he devoted himself with much enthusiasm to theoretical work while the Etrichs carried out practical experiments. In 1899 the father and son built a glider with a span of thirty-three feet that was designed to be started from a trolley running on sloping rails, but this mechanism was found useless for large-sized machines.

As flying was still regarded as an acrobatic feat at that time, Etrich engaged Wels, the Viennese teacher of gymnastics and fencing, to carry out his practical experiments. After a long pause in his constructive activities Igo Etrich brought out in 1929 a small sporting motor plane built in accordance with his earlier experiences, but in more modern form. He tells us : " We, too, were prepared to learn from Nature. We studied the flight of birds and even enlisted as teachers two living vampire-bats. Among my father's many books on flying we found a work by Prof. Ahlborn, of Hamburg, *On the Stability of Kite-like Planes*. In this work the investigator drew attention to the flying seeds of a Javanese palm, *zanomia macrocarp* which can cover wide distances

" We regarded this phenomenon as a signpost of Nature.

We made paper models, increasing their size as we gained experience. In 1904 a big model of a gliding machine carrying a load of fifty-six pounds made quite considerable flights. A year later we designed a large machine with a span of forty feet, which was completed in the following year. Started from a rail trolley and carrying a bag of sand, it flew down into the valley in a beautiful, calm gliding flight, and landed smoothly, without any artificial steering, a thousand feet from its starting point."

How was this possible without any steering gear?

"The chief peculiarity of the flying seed is that its wings have a pronounced backward and upward curve. The action of the *zanonia's* surface is therefore the same as that produced by the combined effect of a wing and a stabilizing plane. The typical feature of my flying machine was that it consisted of nothing but carrying surfaces, which were nevertheless stable."

On October 8th and 13th, 1906, Wels carried out successful gliding flights in the presence of numerous spectators and flew a length of eight hundred and sixty-five feet and a height of sixty-five feet.

During the following winter Etrich built a motor plane which he provided with flexible wing tips, although he was still ignorant of the Wrights' experiments, which did not gain publicity in Europe till 1908.

Etrich was an inventor of an original turn of mind. When Wels, his fellow-worker, saw the brothers Wright fly in Paris and refused to have anything more to do with monoplanes, he struck out a line for himself by designing the Etrich-Taube, which, owing to an agreement with the German, Rumpler, concerning patent rights, is better known under the latter's name than that of its real inventor.

The Etrich-Taube was certainly as famous in Europe as the Wright biplane in America. It was the steadiest aircraft the world has ever seen and a notable product of the research carried out in the field of gliding.

FRANCE

Since the year 1898, Ferber, an artillery captain, had built and tested six different types of gliders. He was

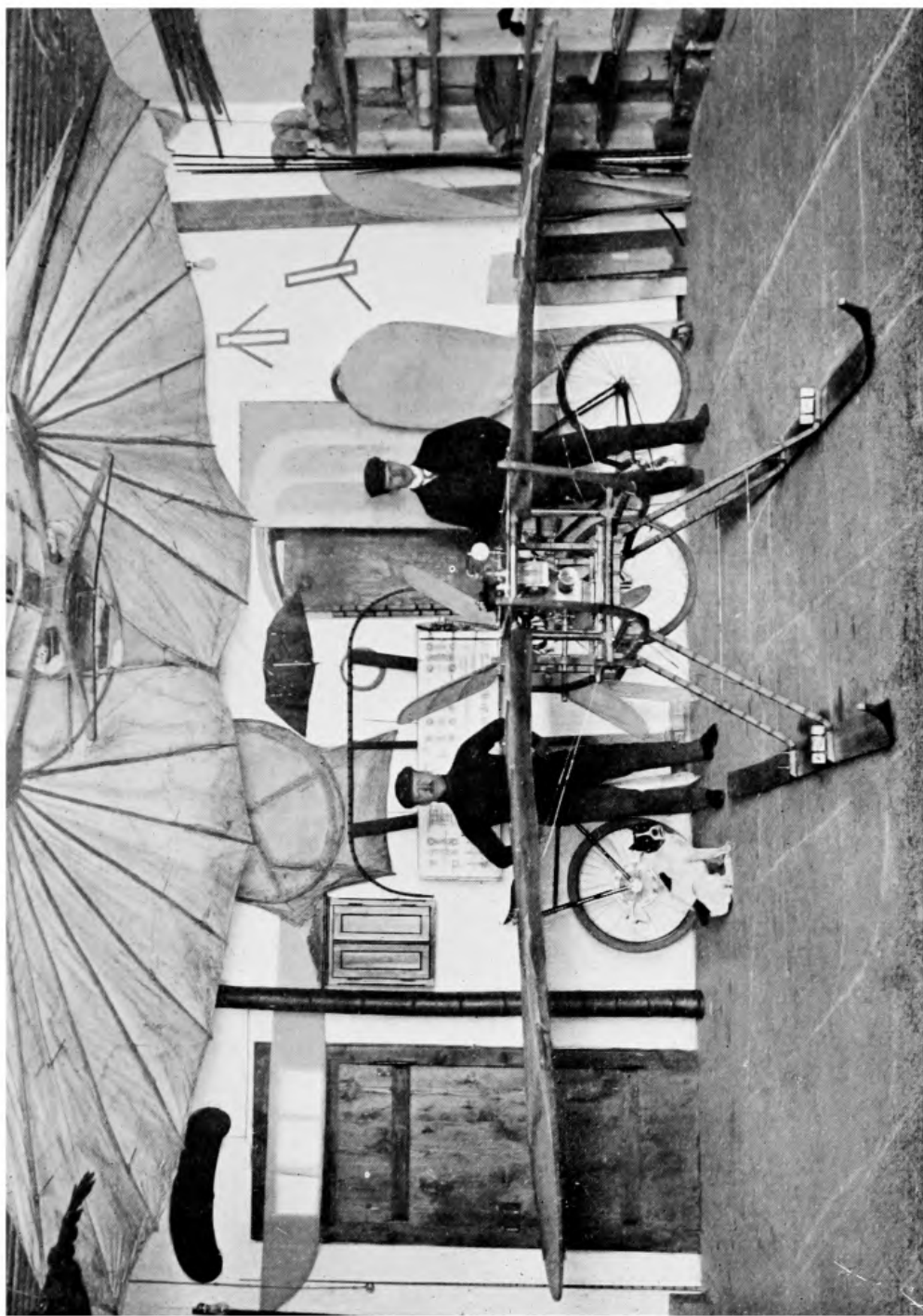

10. A VIEW OF THE WORKSHOP OF ETRICH AND WELS, TWO AUSTRIAN PIONEERS, AT
OBERALTSTADT, NEAR TRAUTENAU

A Glider of 1904 with skids and a 4 h.p. motor-cycle engine. Above: A Lilienthal Glider



11. MARTENS IN THE "MORITZ" (LEFT) AND THE DOUBLE-SEATER OF THE DARMSTADT FLYING GROUP (RIGHT)

only successful when he began to imitate systematically the types of machines brought out first by Lilienthal and later by the Wrights. Building upon the foundations, he proceeded to original work.

Ferber undoubtedly inspired the movement which afterwards led to the rapid successes of flying in France. He it was who supported that enthusiastic patron of experimental flying, M. Archdeacon, with advice and assistance when he organized the first gliding trials at Berck-sur-Mer in 1904. He also showed the young mechanic, Voisin, how to handle the new apparatus, and carried out several scientific experiments in person. With much detail Ferber tells us how the brothers Voison began the career that was to end so brilliantly.

“After a lecture which I gave in Lyons, Gabriel Voisin came to me and told me that he wished to devote himself to flying. We recommended him as a workman to the engineer, Archdeacon, but he received him coldly and said that he had no opening for him. Voisin left Archdeacon’s house downcast but espied before its door a broken-down motor-car. Always industrious, he set to work to repair it, and by a happy chance Archdeacon came out and saw the quick, neat work of the young mechanic. Convinced by it that such a talent might be useful to him, he gave Voisin a job in his works, even although there was no vacancy at the moment.”

At first Voison was used for experiments. At Berck-sur-Mer he undertook a number of trial flights of various kinds in gliders, after which he had to fly for Archdeacon and later for the celebrated Blériot in all sorts of airplanes over the Seine and Lake d’Enghien. He was a veritable odd job man ; he patched planes, rivetted fittings and repaired everything.

With a hydroplane which was started by being towed out by a motor boat Voisin reached a height of fifty-five feet and flew nearly five hundred. One such flight nearly ended fatally when he tried out a machine intended for Blériot, as it crashed into the Seine, and the daring pilot had much difficulty in emerging from beneath the floating wings

In 1905 Voisin left his employer and, with the help of Blériot who put up a capital of six thousand francs, he made himself independent, opening an aeroplane factory under the style of Blériot & Voisin. But Voisin soon outgrew this partnership and founded with his brother the new firm of Voisin Brothers, which made an early success with the Farman and Delagrangé machines.

The brothers Voisin built everything that could be built if anyone would pay for it. They allowed themselves the liberty of turning out some strange machines to designs supplied them by their customers because they had proved satisfactorily that the aeroplanes built on their own plans always flew.

Voisin's steady progress was a great encouragement to many who subsequently made use of his practical experience. Langley in America, Maxim in England and Kress in Austria had endeavoured to help mankind to fly by experiments based on a profound knowledge of the science of engineering, but it is curious to note that while the latter two spent enormous sums on machines that were severely damaged or totally wrecked on their early trials, the brothers Voisin, a couple of simple mechanics who could not solve arithmetical problems, built aeroplanes with the knowledge they had gained from practical experience with gliders . . . and they flew.

“ My worthy friend, grey are all theories,
And green alone Life's golden tree.”

says Goethe, while Ferber, the teacher and patron of the Voisins, impressed it on his pupils that it was no great achievement to design a flying machine, that the man who built one had made some progress, but that the really important thing was that it should be able to fly.

Voisin always waxed enthusiastic over the gliding experiences that had helped him to his fame, and described gliding as the most exhilarating sport that could be imagined. “ By means of incessantly increasing practice a glider pilot undergoes an extraordinary physical development. He rapidly gains power of decision, an accurate sense of aerial motion, and above all, the faculty of reacting instinctively

to unforeseen events, all of which qualities are of the highest value to him later when he must handle a heavy engine-driven machine which exacts the highest degree of concentration and extreme rapidity of decision at critical moments.”

ENGLAND

“ Mr. José Weiss—as is our English custom—is much better known in the United States as a great painter of English landscapes than he is in this country in his more important manifestation as a great pioneer of aviation.” Thus speaks Mr. F. Grey, the editor of the English aviation journals, *The Aeroplane* and *All the World's Aircraft*, in his preface to a book by Weiss's son, Bernard, who gives an excellent account of the development of gliding and soaring up to his time in his *Gliding and Soaring*.

“ In 1909, when I first had the honour of meeting him, José Weiss knew more about the aerodynamic design of an aeroplane than do any but a minute number of our leading aeroplane designers and aeronautical scientists to-day. I say this deliberately and not as a figure of speech, for our brightest brains to-day are constantly announcing with the air of a Christopher Columbus discoveries which to José Weiss were mere commonplace facts.”

Everyone has seen in the circus artistes who balance various objects on their noses and foreheads. When such a man has acquired sufficient practice he can hold a walking-stick so still that you would think it was suspended in the air. But should the attention or the activity of the artiste falter for a moment, the stick falls to the ground at once. With a pendulum the exact opposite occurs. You may place it in any position you like, but it returns of its own accord to the only one in which it can find safe repose. It corrects mechanically every disturbance of its equilibrium.

This maintenance of equilibrium is what José Weiss meant by “ natural stability.” His train of thought was a completely independent one, and yet it developed along very similar lines to those which Etrich had followed. Both told themselves that an aeroplane must be able to fly by itself before human beings could be entrusted to it.

Weiss was not afraid to differ from the current opinions of his day. He sharply criticized Prof. Langley's views concerning the internal work of the wind on the ground that the steady ascent of smoke, clouds, or a balloon seriously contradicted the presence of this inner activity. In this respect he carried out innumerable experiments, chiefly with models, from which he gained rich experience. "I have," said he, "been experimenting with models of gliders on and off ever since I was a boy, but it is especially since Lilienthal's unfortunate death that I have taken this up as a regular hobby, and in these past five years alone I reckon that I have constructed no less than some two hundred of these models."

The models he designed and the experiments he made with them are typical features of Weiss's work. None of his predecessors made so many trials or obtained such good results with small models that cost hardly anything. He even succeeded in calm weather in approaching the ground at an angle of only three degrees, i.e., his model, starting from a height of three feet, could glide a distance of sixty. These little artificial birds were possessed of such intrinsic stability that they could fly by themselves like real birds. About one of them he says : "I launched it yesterday and the results were so remarkable that I hardly expect to be believed ; I do not know that I should believe in them if I had not seen them myself. There was a north-east wind blowing at the rate of about twenty miles. I had favourable circumstances and I launched it about twenty times. Once it stood for forty seconds quite motionless. It was launched on the ground, rose to thirty or forty feet, did not turn, die nor lose its height and remained hovering like a hawk or a kestrel. It is a positive fact."

There have been and are to this day innumerable theories concerning the flight of birds. Some of them are most confused, and many of their exponents believe that Langley's conceptions are the only acceptable bases for arriving at the nature of bird flight. Weiss, however, held that if it was once realized how slight a gliding angle may be made, how little energy is necessary to change this gentle downward movement into hovering or even climbing, it

would never be necessary to seek such complicated explanations.

Weiss did not stop short at his experiments with models. He built man-carrying gliders, the first of which was constructed in 1909. These machines differed from the models only in size, and were similar in flying capacity. The 1909 machine had what Weiss calls automatic stability ; it was unbraced, and therefore a predecessor of many high-grade modern machines. Even inexperienced pilots made considerable flights in it.

At first a new starting arrangement was employed. The take off was accomplished by the aid of two steel hawsers which were laid in the direction of the wind each time, the machine rolled downwards on a trolley, and its descent was hastened by a drop weight which reacted upon a starting rope. Later Weiss substituted steel rails for the hawsers and made alterations to his catapult which enabled it to be turned against the wind. His simplest and last discovery was that if the machine was merely rolled on wheels down a slope towards a sudden fall in the ground it would be lifted by the wind when it reached the edge, if its velocity was sufficient.

Unfortunately Weiss had to give up his experiments for lack of money, but his experience was not lost. Mr. Handley Page had always been especially interested in his work, and built his first aeroplanes in 1911 and 1912 on designs based on his deductions. Likewise, Weiss had imitated Nature, deriving much assistance from Alexander Keith, who was a student of birds and had an exact knowledge of their anatomy. From what they had learned from Nature they drew conclusions which led them to principles of construction that could be applied to the building of flying machines of any size, and they pointed out that such planes would be found to possess a high degree of efficiency which could only be properly appreciated when they were in the air.

Have you ever seen a boomerang which, when skilfully thrown so that it whirls in the air, climbs high and then returns to its starting point ? Have you ever asked a learned man to explain this phenomenon ? I do not believe that

he could do so quite accurately, as the Australian boomerang is still a great mystery to us Europeans. Captain G. W. Dunne, an officer in the Royal Engineers, was greatly puzzled by the problem of the boomerang ; moreover he had long been interested in problems of flight, and we are told that the celebrated writer H. G. Wells helped him in his inquiries.

Dunne kept all his researches as secret as possible, but contemporaries who knew his work are of the opinion that his planes were in many respects better than those of the Wrights.

He constructed his machines according to the principle of boomerang flight, and his gliders therefore differed greatly from all that had gone before. Here it is very interesting to observe that by entirely different methods he reached conclusions almost identical with those obtained by Weiss from his observation of bird flight and by Etrich from the study of his flying seed. Like Etrich he built a tailless plane in which longitudinal stability of the wings was obtained by an arrow-shaped arrangement of surfaces. The wing tips were curved upwards, like those of the Taube.

To-day many experts are interested in the idea of a gigantic aeroplane without a tail. It would consist of nothing but a vast wing capable of harbouring passengers, engines and freight, and would be able to fly great distances. It is certain that this type will be achieved at some future date because gliders and soarers had almost developed it before a practical engine-driven aeroplane was evolved.

BACK TO GERMANY

The circle of the wonderful development of a technical novelty is now completed. It began in Germany ; England took it up and studied and tested it. America and Austria developed it practically ; French ardour and enthusiasm converted a whole country to a love of aviation. But in his homeland Lilienthal and his work seemed almost forgotten.

In 1907, however, Offermann experimented at Aachen with a biplane built on the Wrights' system. Later

he went to the Harz Mountains, where he had an artificial starting-hill laid out for him. He started his machine by means of a catapult and a drop-weight.

In 1909 and 1910 he began original experiments with two new machines, which were so constructed that he could turn his two wings in similar or opposite directions. His most interesting machine was a so-called "Duck," a fuselage machine with very low resistance and an elevator that rose from the body which projected in front of the wings.

There is one man in Germany who does not forget Lilienthal, and that is his brother Gustav. If to-day you should arrive by aeroplane at the Berlin Air Port you will find in one of the side hangars a grey-haired man working on a gigantic bird, and when you tell him that you have just arrived by the regular Air Service he will shake his head. "That is nothing," he will say, "nothing at all; that is only brutal force. The engine drags you through the air. Also what soarers do to-day is nothing. They fly, it is true, with their stiff, stark wings a hundred miles across country and rise to a height of ten thousand feet, but it is all nothing. Look here, you must be able to beat your wings like my bird; then you will easily fly like birds."

Then the old man will resume work on his apparatus. He will turn a crank, and great wings will rise up groaning. At one spot a spar may crack and a cloud of dust whirl up.

Reverently we must listen to the tale of how he and his brother searched and strove and flew. And if he then speaks of his own work in the days when he trod the path which we now know to be a false one despite the many grains of truth with which it is strewn, we dare not contradict the man who swore to be faithful to an idea, and cannot now free himself from it.

Outside, before the great hangar, the aeroplanes start and land, and among them you will see light machines designed on models constructed from the experience won in gliding and soaring. Their diminutive engines are almost toys, but they have a great future.

Sport, youth and technique pursue hand in hand the path to victory.

TEN YEARS OF COMPETITION—TEN YEARS OF EXPERIENCE

EVEN many of those who are well acquainted with the history of the Rhön gliding and soaring movement believe that it began with the first competition in 1920, and that no work was done between 1910 and 1920. The tests and experiments made by the Darmstadt High School boys in their free time were generally regarded as mere amateurish sport, but nevertheless we owe them far more than might appear at first sight. The soaring flight district of the Rhön was first opened up by these boys.

In the year 1909 one of them, Hans Gutermuth, went with his friends to the International Aeronautic Exhibition in Frankfort-on-the-Maine. Impressionable as such youths are, they went home filled with enthusiasm and began to make and fly their own models. They founded a Flying Sport Club, and proceeded to construct monoplane and biplane hanging gliders on the model of Lilienthal's machines. The first flights were made from a woodstack and from "Chimborazo," an elevation on the Darmstadt parade ground. Young as were these enthusiastic disciples of flying, they were heart and soul in their work. They built planes of varying types, learned much, gained much experience by each new effort and kept careful technical records of all their work. Soon they felt the need of higher hills for their starts. In the autumn of 1910 Hans Gutermuth and his friend Berthold Fischer set out on a tour through Germany and carefully explored many mountain regions. They wandered through the Thuringian, the Harz and the Rhön Mountains, and in the Rhön, on the Wasserkuppe, they discovered the ideal field for flying practice, although it was only possible for them to begin their trial flights there when a cowshed was placed at their disposal. It was workshop, dormitory, and hangar. Then, in the

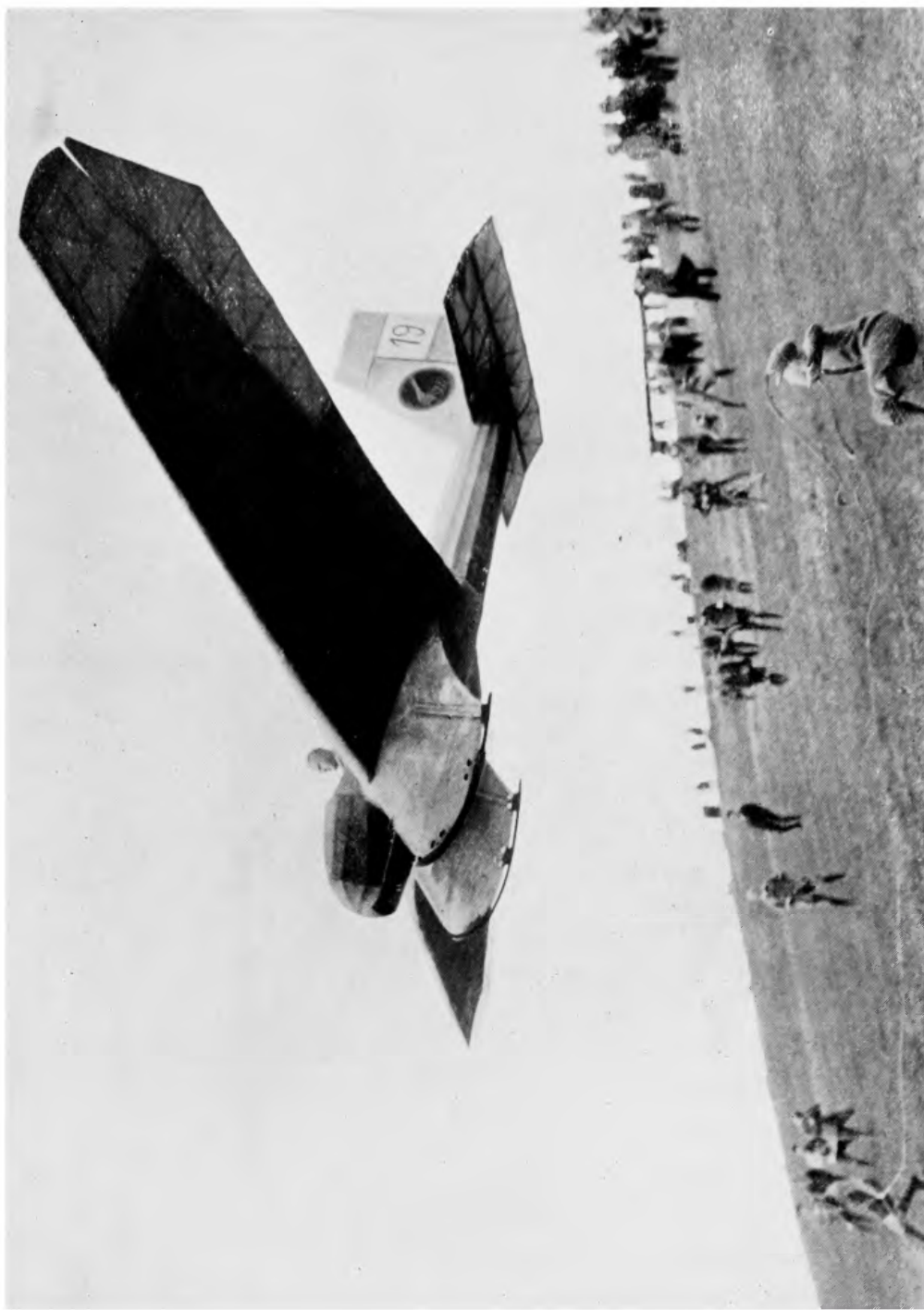

12. THE MACHINE BUILT BY KLEMPERER FOR THE AACHEN FLYING CLUB. KLEMPERER'S WORK WAS SIGNALIZED FROM THE VERY BEGINNING BY A SOUND KNOWLEDGE OF AERODYNAMICS



13. "KONSUL," THE MACHINE BELONGING TO THE DARMSTADT ACADEMIC FLYING GROUP. A PROTOTYPE OF THE MODERN HIGH-PERFORMANCE MACHINE WITH A WIDE SPAN

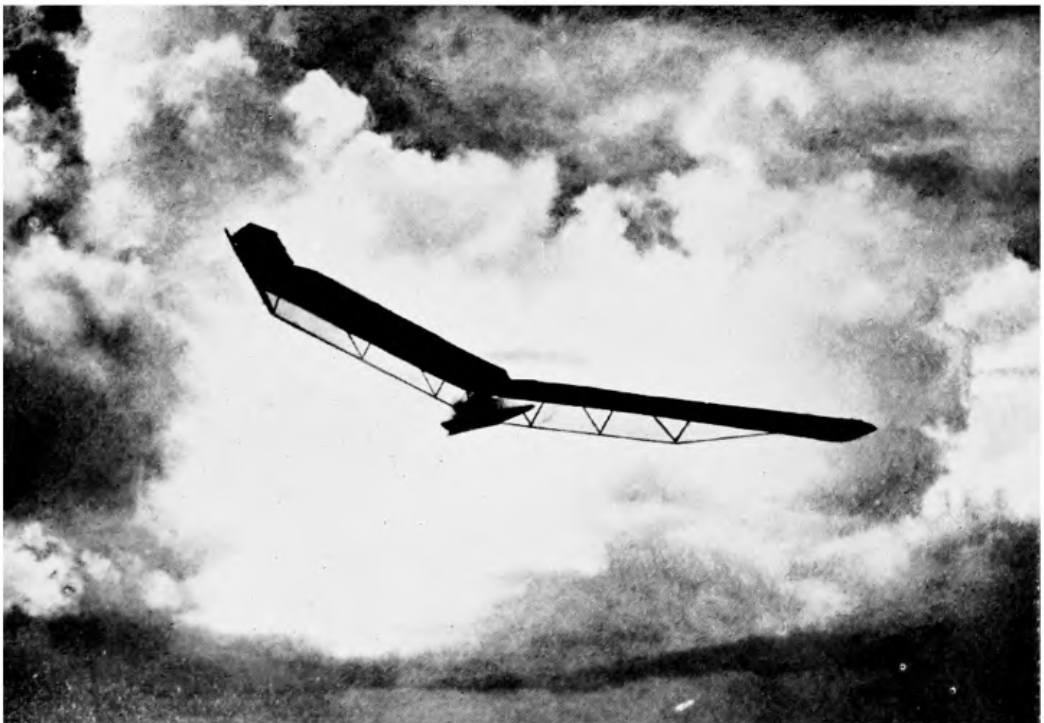

14. THE TAILLESS MACHINE IN WHICH LEUSCH CRASHED TO HIS DEATH IN CONSEQUENCE OF A BROKEN WING AFTER A SHORT BUT PERFECT SOARING FLIGHT

Facing page 55

holidays of 1911 and 1912, the hilltop became the home of eager building and flying activity. How enthusiastic they were may be gathered from the fact that nearly thirty gliding planes of different types were built. The first of these, which were spanned with linen sheets, carried out from the Wasserkuppe flights of from six hundred to a thousand feet long. As early as in 1912 Hans Gutermuth flew a distance of nearly three thousand feet and remained in the air for one minute and fifty-two seconds.

When criticizing these results, we must not forget that it was not easy to find young people of that age who were ready and willing to take up such earnest work and face all the hardships it involves or who possessed the necessary patience and staying power. The reason that so little is known about this labour of love on the Wasserkuppe may be due to the fact that five out of the ten comrades who took part in it found an airman's death on the battle-field. But their tradition of comradeship and of mutual assistance in scientific and technical work was taken over by the Academic Flying Group of Darmstadt, which has played a part of the greatest moment in the development of soaring flight.

The activities on the Wasserkuppe—that eyrie on the Rhön—form the finest memorial to these young pioneers.

THE ROUSSEAU OF FLYING

At the Jubilee prizegiving after the tenth great Rhön Flying Competition a man stood with the successful pilots who was destined to take no large sums of money home with him, to receive no silver badge or cup.

He was greatly surprised to receive anything at all, for he was not a pilot. And yet he was presented with a special honorary prize! A hat! Yes! A fine, new broad-brimmed hat!! But the hat itself was not the essential thing. What really mattered was its ribbon band, which bore the legend—"For the next ten years."

And so his old hat was superseded, and high time too. That old hat, so runs the saga, Father Ursinus of the Rhön first placed upon his head in the year 1920, swearing that

he would wear it and no other until Soaring Flight had become alive, independent and vigorous.

And indeed such strong measures seemed necessary at that time, for the work required to bring about the desired result seemed to assume gigantic proportions to the soarers of that day. They had no basis to start on—no experience—no enterprise—no money. In those dreary days that followed upon the end of the war even the boldest hung their heads for a time, but then it was that Oscar Ursinus, a civil engineer of Frankfurt-on-the-Maine and publisher of the magazine *Flugsport*, arose and called about him a body of disciples. Even as Rousseau preached the return to nature to a world rigid in its conventionality, so Ursinus preached to aviators the return to gliding and soaring.

Everyone knew that the flying barndoor or wire cage with its 400 h.p. engine was not on the right path to the future development of flying, but Ursinus was the first to point out and open up the correct way. He emphasized again and again that flyers must go back to the era of motorless flight in order to free themselves from the habit of relying upon a too great reserve of mechanical power. He urged them to pursue the personal and practical study of gliding and soaring side by side with that of the constant improvement of scientific technical equipment. Their primary object, he maintained, should be to make flying once more a sport in the true sense of the word and so to acquire new knowledge and perhaps eventually lay the foundations for the development of the new light flying machine that was to come.

First a fund was collected. Clubs, industrial concerns, and the state all contributed to it—some of them freely, others unwillingly enough. But this did not suffice. Man is a sluggard and must be shaken up from time to time. So articles accompanied by maps began to appear in *Flugsport*; they described the part of the Rhön district and gave information as to how to reach this “wild country” by train. A depôt for the supply of materials was opened, and ways and means for lodging moneyless young folk were thought out. Then it was that Ursinus, the aeroplane constructor, planned the “sleeping-box,”

a collapsible box that could be carried easily from one spot to another, set up anywhere on the mountain and used as a bunk.

And then came the announcement of the first meeting.

Prizes were offered for flights in motorless gliders, with the object of promoting gliding as a sport.

There was a prize for the best utilization of the wind as a lifting power, and another for a flight actuated by man power, the object of which was to develop the length of gliding flights and bridge over gaps between upward gusts of wind by human skill and strength.

There was also a competition for planes provided with small auxiliary motors that would do the work otherwise done by man power. The highest motor power allowed for these was 5 h.p., the special aim of this class being to decrease as far as possible the motor power of aircraft.

“ It is difficult to leave the old paths for new and unknown ones. Efforts to develop in new directions the flying modern machines, in which the flyer may be said to sit upon the motor, will not help us far towards the attainment of our ambitions. It is better to begin again from the beginning. How much horsepower is necessary to enable us to fly? This is the question which the Rhön shall answer. . . .”

And, positively, things began to move everywhere. The Society for Scientific Aeronautics became honorary patrons of the scheme. Four wooden barracks were put together on the Wasserkuppe, in which a dormitory, a workshop and a meteorological observatory were fitted up. Tents were erected, and thirty camp beds were provided. And now began—very gradually at first—a pilgrimage to the Wasserkuppe. Each pilgrim had to bring his own pillow and blanket ; very grand folk had sleeping sacks and hammocks. Camp stools, cameras and the like were luxuries, but pots and pans and tools were matters of great importance. Ablution facilities were arranged in the open air at the spring which is the source of the Fulda.

Under these conditions flying enthusiasts worked happily together ; there were senators and students, carpenters and engineers, war pilots and men who could not fly at all.

And what a beginning! There were many useless efforts! And then, on August 6th, 1920, at four in the afternoon, a little white monoplane was seen to float for nearly ten seconds above the same spot! Two days later Freiherr v. Lössl, flying a machine of his own construction, remained in the air for forty seconds and covered a distance of four hundred and fifty yards.

It was not easy at first, but their hopes ran high. At one time, however, it seemed as if they were to be denied even the consolation of hope.

On August 9th, v. Lössl started with the intention of carrying out a longer flight. The weather was unreliable, the wind very capricious, and great clouds hung above the summit. Maintaining a good height, v. Lössl was gliding along over the steep hillside, when suddenly a heavy squall took him by surprise. His elevator was not strong enough; it broke, and he crashed after a flight of eighty seconds, in which he covered a distance of eight hundred and eighty yards. On August 9th, 1896, Lilienthal had crashed, all alone in the Rhinow Hills, and now, twenty-four years later, when the German soaring flight movement was making its first efforts towards a new and vigorous life, the supreme sacrifice was exacted from its second pioneer.

But those who thought that this accident would check the movement failed to realize the wonderful Rhön spirit. Just this flight had demonstrated the possibilities of utilizing a strong wind. The highest honour that could be paid to Lössl was to carry on his work, and this was done with redoubled zeal.

But at that stage very little could be achieved. The results almost seemed to show that flights in a hanging glider after the model of Lilienthal's (Pelzner demonstrated his marvellous bodily skill in one of these) were to be our best feats. Then, a few days before the close of the meeting, a new machine arrived. Herr Klemperer, an engineer of Aachen, had constructed it on a totally new plan; it had thick cantilever wings, and was lighter than any machine of the new type which had been hitherto built.

With this "Schwarzer Teufel" (Black Devil) Klemperer, a former war pilot, flew on September 4th, 1920, for two

minutes and twenty-three seconds, covering a distance of over a mile. Three days later he made a highly interesting flight in which he flew for forty-five seconds at a wind velocity of from fifteen to twenty yards per second, covering a distance of only two hundred and fifty yards, but rising thirty-three feet above the starting place. This was real soaring.

This was, of course, only a modest beginning, but the real success was not to be reckoned in figures. The right people had come together; enthusiasm had been awakened. "Next year we will be here again with twice as many machines, which will be very different ones from those of to-day. And at least, we know now how to fly them." These and many similar words were heard when the camp broke up.

Moreover, various independent experimenters were present who did not take part in the general competition, among them being Herr Harth, an architect, who had been experimenting since 1910. In 1916, starting from the Heidestein, a hill in the Rhön district, he had flown for three and a half minutes without losing height, using a machine he had planned and constructed in conjunction with a certain Messerschmidt. He made some good flights in the course of the meeting.

Meanwhile an interesting model was being tried out in all secrecy in the Black Forest. Wenk had designed a plane without a tail, which was as far as possible an imitation of the pinions of an albatross. On August 15th, 1920, this plane described a complete figure of eight, in the course of which the soarer flew twice over the starting place on the Feldberg at a height of sixty-six feet. The flight lasted two minutes and a half and finished quite near to its start.

In 1921 there were twice as many competitors as in the previous year. Among the newcomers was Ferdinand Schulz, who was destined to rise to fame later, and several interesting groups of flyers from the Universities and Technical Colleges of Darmstadt, Hanover and Munich. In a fortnight a hundred and twenty-eight flights were made.

One of the prizes offered this year was known as "The Great Rhön Prize." To win it a flight of five minutes was required, which had to finish at a landing place not

more than one hundred and sixty-five feet below the starting-point. This demanded true soaring, and no one succeeded in fulfilling the conditions. The indefatigable Pelzner had often succeeded in flying for fifty seconds in his hanging glider, and later he increased his time to more than a minute. His feats alone justified the severe demands made upon better machines.

Klemperer had brought his excellent plane, and on August 8th he made a gliding flight of thirteen minutes and a half. But now he had a rival, for the Hanover student, Martens, beat Klemperer's distance record on August 21st by nearly two miles. He had a new plane, the " Vampire," which had been designed by an engineer, Dr. Madelung, with the help of Prof. Pröll and another engineer named Dorner. This is the machine that for years remained the best type for soaring flight and may be regarded as the first example of a modern high efficiency machine. The fundamental principle in the construction of this plane was the resemblance of its wings to those of sea birds, their span being very wide and shallow. A few days after its trial flight it carried Martens for a gliding flight of over two miles, in the course of which he described two complete circles. Then Klemperer regained the record with a flight of nearly four miles and a half, only to have it wrested from him again by Martens shortly afterwards.

But in spite of all efforts these flights were merely glides ; the art of soaring still remained a sealed book to most flyers. The industrious Harth undertook further secret trials, and at length showed the world how soaring flights could be accomplished. On September 13th, 1921, he gained a world record by flying above the Heidelstein for twenty-one and a half minutes, in the course of which he soared correctly in a wind of from ten to twelve yards per second. He circled repeatedly above his starting-place, flew along a considerable stretch of slope ; demonstrated his ability to turn, and finally landed only 170 yards from his starting point and forty feet below it. It was a fine piece of flying work.

This year also demanded its sacrifice. Wenk's tail-less soarer, which had been flown in the Black Forest the

year before, had come to the Rhön meeting this year, and on August 14th an experienced war pilot, Wilhelm Leusch, started in it.

This machine started differently from the others ; it was hoisted on the shoulders of several men, who ran with it against the wind. Silently the plane rose, and began to climb towards the storm. The impression made upon everyone present was indescribable ; hitherto they had only seen gliding flights, but this was soaring. When the machine had been little more than a minute in the air and flown about a mile above its starting place, a cloud compelled the pilot to turn away. The turn became steeper and steeper until people realized that something—probably the steering—had gone wrong. Suddenly a wing broke off, and the plane crashed down, burying the pilot beneath its wreckage.

Those were heavy hours and days, but soaring flight could not now be checked, even by such sad accidents. Before the end of another year exploits were to be performed which would be famous all over the world. The way had been wearisome and hard, but the ideal that was behind the movement had become reality and deed.

RECORDS

DEVELOPMENTS followed as a natural result of what had been learned. We may undoubtedly call this first period of soaring flight the technical period, for at that time the primary need was to create a machine which should enable the pilot to show his skill. The tradition of heavily braced machines had been broken, and the instructors had learnt to combine extreme lightness with extreme solidity. Klemperer had pointed out the way with his "Schwarzer Teufel," while the Hanover man's "Vampire" was a technical triumph of its epoch.

The inevitable results followed. It was the turn of the pilots to get out of the machines all that there was to be got. The sporting period, therefore, began, the importance of which was the publicity given to the exploits and feats of the pilots. Many who knew little or nothing of the activities in the Rhön Mountains now became aware that something great and new had come into existence.

Many sacrifices were made and many things which we should have liked to do were postponed in order that we might concentrate upon advancing as rapidly as we could the promotion of the highest possible efficiency and practical usefulness. We centred our endeavours upon true soaring, and consequently the chief prizes offered in 1922 were: one for the longest duration flight, one for the lowest sinking speed and one for the longest distance flight. The conditions laid down for the competitors were so extraordinarily difficult that it seemed dubious whether it was possible to fulfil them.

The whole course of the 1922 Meeting was extremely exciting. Continual contests took place between single pilots or groups of pilots. For one prize which had been offered for a flight to a goal, a veritable duel was fought out between Botsch, of Darmstadt, in the "Edith," and Hentzen, of Hanover, in the "Vampire." First Botsch

succeeded in flying to within one hundred and sixty-two feet of the goal—a feat in itself—but the next day Hentzen came within one hundred and forty-four feet of it. This spurred on Botsch's ambition once more; he started out and completed the first true soaring flight of the Meeting in the presence of a cheering crowd of spectators. He worked up from the south slope of the Wasserkuppe until he had attained a height of two hundred and seventy feet above the starting place, and then shot forward like a bird of prey towards the goal, landing only forty-eight feet from it. But meanwhile Hentzen was again in the air, and this time his landing place was only thirteen and a half feet from the goal. His feat enabled the Hanoverians to gain the victory in this contest.

Two days later came the first great event of the competition—the soaring flight. Martens, of Hanover, started in his “Vampire;” on the west slope he soon rose in a graceful flight to a height of three hundred and thirty feet above the starting point. He soared far above it over the heads of the watching crowd, who, never having seen such a thing before, stood spellbound with amazement, while he continuously circled above them. Forty minutes flying time were required by the conditions of the great prize, but when twenty-five had passed the wind weakened and continued to drop until Martens could hardly keep himself up. But suddenly he rose again and flew onward like a great bird, remaining in the air (for the first time within human ken) for more than an hour without the aid of motor power. To cap this exploit, Martens finally embarked upon a long distance flight and landed six miles away from the starting place, and one thousand six hundred and fifty feet below it in the valley.

This feat was hailed with mingled joy and amazement, for it seemed to us that the whole world must now be convinced of the possibility of motorless flight. But on the very day this record, too, was broken, for Hentzen, a fellow-student of Martens, made a flight of two hours and ten seconds duration in the “Vampire.” But this failed to satisfy him, and on August 24th, 1922, he gained his world record of three hours and six minutes by reaching a height

of somewhere between one thousand and one thousand one hundred and fifty feet above the Wasserkuppe.

Another marvellous affair was the struggle between the Academic Flying Groups of Darmstadt and Hanover during the last days of the meeting. Far, far up on high hung the "Vampire" and the "Geheimrat," and below them various other machines. In the strong wind the planes remained nearly motionless in the air (at times they were even driven backwards) and the mighty crowd which had been attracted by interest in our feats, followed their every turn with rapt attention.

One achievement continued to surpass another, until it was difficult in the end to say which had made the deepest impression—the wonderful duration flights or Botsch's amazing storm flight in the "Edith."

By this time other countries had begun to be interested in gliding and soaring. This year the Dutchman, Fokker, the famous designer of aeroplanes, had come to the Rhön with a two-seater plane, and was the first pilot to remain in the air for any considerable period in a motorless plane carrying two persons. His time was a quarter of an hour. Technical experts from Holland, Scandinavia, and America spent many days on the Wasserkuppe, and the evenings were filled with lively and most interesting discussions between theorists and practical men.

The exploits recorded above were performed in machines constructed on familiar and approved lines, but many technical novelties were also on exhibition. In addition to new designs brought forward by the Darmstadt, Hanover, Dresden, and Munich Groups, there were the remarkable tailless aeroplane of the Berlin Scientific Flying Association and Klemperer's "Duck." Characteristic of the far-seeing work done by the constructors of that day is the fact that even then they built types of machines that are as interesting to-day as they were then, while the exploitation of the possibilities they afforded is by no means at an end.

The Meeting of 1922 was a tremendous stride forward in every respect. For the first time in a Flying Meeting the results had far surpassed all expectation. We knew

exactly along what lines we must work and could look forward with confidence to the next year.

It was a matter of course that, inspired by these results, men in other countries should try their luck at gliding and soaring. In France there were great differences of opinion as to the value of the movement ; but men of position and name, such as Farman and Bréguet, took up the cudgels for it, while the effective propaganda of Magnan, who is noted for his research work in connection with soaring, caused the offer of a prize for competitive soaring flight. The stretch of country over which the flights were to take place was not so favourable as that of the Rhön Mountains, but this was not the sole reason why this Meeting, in which so many competitors had entered, showed results far behind those of the German competitions. The experience in construction and in the art of flying, which had been acquired with such patient effort in the Rhön, was lacking here. The longest flight which was made with a Farman plane, lasted five minutes and eighteen seconds.

Very noteworthy in the French competition was the plane flown by the American, Allen, which was planned and built by the teachers and pupils of the well-known Massachusetts Institute of Technology. Towards the end of the Meeting a monoplane tandem built by Peyret arrived, but failed to achieve anything of note.

In England the *Daily Mail* took the lead in the movement by offering a large prize. The first English Meeting took place from October 16th—21st at Itford Hill, where the territory was most favourable and the results excellent. The Frenchman Maneyrol, flying a monoplane tandem, broke the German record by remaining in the air for three hours twenty-one minutes and seven seconds, while a series of other fine flights were made in which many of the flyers remained aloft for more than an hour at a time. How good the upwind conditions must be there is evident from the fact that Grey flew in a machine which had been put together from the wings of one motor-plane and the cockpit of another. This plane, which was at first treated as a huge joke, was christened the "Brokker" because the fuselage had been taken from an English Bristol warplane

while the steering gear had belonged to a German machine, the Fokker "D.7." But so good were the flying conditions that even this plane did great things under Grey's wonderfully skilful piloting.

The hilly land on which this competition took place extends in both northward and southward directions. The wind on the chief soaring day had a velocity of forty-nine feet per second. The greater steepness of the slopes produces better upwind conditions but demands special flying tactics, and the thanks of the promoters are due to Fokker for having made this clear from the very beginning. He arrived there in good time to study the country and made careful observations by means of kites. So cleverly was he able to take advantage of the strong currents that on September 16th he soared with a passenger for thirty-seven minutes. Five days later the Englishman Olley flew in the Fokker plane with a passenger for forty-nine minutes.

On the whole planes that could do very little in the Rhön were able to make quite good flights under the more favourable wind conditions in England.

Undoubtedly the best machine there was the "Maneyrol," which was in fact an exact, full-sized replica of the model which Prof. Langley had built long before. Although technical experts had expressed the most unfavourable opinions with regard to the chances and capabilities of this machine, it proved, in spite of them, what a genius old Langley had been.

In the meantime Germany was preparing for another competition. In Berlin was founded the Soaring Flight Association, the forerunner of that great Association which to-day directs flying progress in Germany—The Rhön-Rossitten Gesellschaft. It had as its objects the furtherance of Soaring Flight in all respects—commercially, scientifically and as a sport.

Great expectations centred round the forthcoming competition, but difficulties soon began to arise. In the early period of soaring flight in all countries we find that over-much importance is attributed to endurance flights

and their records. Although duration flying was very necessary in the early days in order to accumulate soaring experience, persistence in such flights after their purpose has been served is the surest way to bring a promising beginning to a standstill. Duration flight only trains pilots with staying power and neglects the sensitive ones. It does not lead to that progress in the technical and scientific directions upon which all future development must be based. Many flyers recognized this fact, but they were uncertain as to the direction in which progress was to be expected and looked for it along the lines of the previous year's developments.

Prizes were offered for distance flights of more than twelve miles, during which a height of over one thousand one hundred and fifty feet should be attained. Soaring with the aid of a small engine, which had fallen into the background during the last meeting, was again brought forward, but the general interest was so concentrated upon soaring proper that few competitors were found to enter for this prize.

On the other hand there once more appeared a whole host of new machines of notable and interesting construction. In addition to various experiments with planes provided with wings that could be turned or curved, the constructive type which promised most for the future was the "Konsul," sent by the Darmstadt Group. It had pinions with a span of sixty-six feet, which were attached to a slender cockpit of ply-wood. This was certainly a daring experiment at the time, but later it fully proved its value.

In spite of its ninety-seven entries, the Meeting of 1923 fell far below the level of the previous year. No one succeeded in reaching prize standard. The extremely unfavourable weather must be blamed chiefly for this result. The best achievements were an eleven-mile distance flight by the "Konsul" and a flight in which Hackmack attained a height of a thousand feet. This flight of Hackmack's was made in a heavy storm, and was chiefly valuable for its demonstration that soaring was possible in all kinds of weather, provided that the machines were sufficiently strongly built.

The day after this flight was devoted to the unveiling and dedication of a memorial which had been erected on the summit of the Wasserkuppe to the memory of those who had lost their lives in the service of flying. It had been arranged that flights should be made in their honour, and in spite of a violent storm the chosen pilots started. Dramatic scenes were witnessed, because in spite of the bad weather no one could be dissuaded from putting his machine and skill to the test in honour of this ceremony. Thomsen's plane, however, proved unequal to the struggle with the heavy squalls ; the wings began to sway more and more violently, and he tried to land. He brought his machine to within six yards of the ground, where one wing broke off suddenly, and the plane crashed. Trachinsky's " Galgen-Vogel " (Gallows Bird) had no better luck, as it was dashed against a hillside and wrecked. Both pilots escaped with injuries, but the day demanded its human sacrifice. The plane piloted by Max Standfuss was not strong enough for the storm, so that the breakage of a wing at a height of a hundred feet caused it to crash.

But once again the tragedy only served as an incitement to the survivors. The flights in the storm had made a tremendous impression upon all who saw them. But, nevertheless, and in spite of the fine distance flight which Botsch brought off shortly before the close of the Meeting, it ended on a note of depression.

The official French Meeting of this year achieved no noteworthy results, a flight of three miles by Flight-Lieutenant Simonet proving the highest attainment. There was also a fatal accident when the over-weak wings of Hemmerdinger's plane broke. But certain special flying feats before this Meeting had already demonstrated the good results of the experience which had been gained from the first French competition. For one of them a very fine flying field was chosen, and it proved so excellent that Flight-Lieutenant Thoret was able to keep on soaring in his motor-plane of the " Hanriot H.D. 14 " type when the engine stopped. This record flight of seven hours and three minutes was flown in the neighbourhood of Biskra on January 3rd, 1923.

This feat of endurance was beaten by Louis Peyret with the plane with which Maneyrol had already done great things in England. Peyret flew for eight hours and five minutes at Vauville, near Cherbourg, and two days later Georges Barbot, flying a Dewoitine monoplane, beat his record with eight hours thirty-six minutes and fifteen seconds.

The balancing of our accounts for that year would show Germany best in distance flying but France more than twice as far ahead in endurance flying.

THE LEAN YEARS

BUT other results were obtained which proved far more important than mere records. In the first place it was demonstrated that gliding and soaring were practicable over various types of country.

The German flyers came together for a meeting in Vienna, where Martens flew six miles, remaining in the air for three quarters of an hour, while the tailless plane belonging to the Berlin group made itself conspicuous by many pretty flights. The Vienna meeting was also noteworthy for the appearance of a new "ace," in the person of "Espe," as his comrades nicknamed young Gottlob Espenlaub. He was one of the early pioneers of the Rhön, where he had even spent the winters of 1921 and 1922. A shopkeeper in the district told me later that "Espe" had come to him one autumn and bought a sack of oatmeal, which, with a little dripping, was his sole supply of food for the winter. But he brought to Vienna two planes he had built with his own hands. He could not fly! So he had to look on while a strange pilot smashed one of them to pieces.

"I couldn't do it worse myself," said Espenlaub, and started off in the other machine one morning before anyone was awake, although he had not the least notion of what to do in the air. This first flight of his life was made from a hill a thousand feet high, and he flew nearly two miles—a most unique feat, for his maiden flight won a distance prize.

From that time on "Espe" made his own crashes, and played a great rôle in the history of German soaring flight. He is a living example to flyers of what it is possible to accomplish alone and unaided. He is the son of a shepherd, and began his associations with the Wasserkuppe by fetching water for the landlord of the "Baude" (The Hut) as we call our first shelter there. Thus he earned many a plate of hot soup.



15. THE "ESPENLAUB 5" IN FLIGHT. ONE OF THE MACHINES WHICH ESPENLAUB, THE JOINER, BUILT AND FLEW



16. FERDINAND SCHULZ IN HIS "BROOMSTICK," A MACHINE WHICH ACCOMPLISHED MARVELLOUS FEATS IN SPITE OF ITS PRIMITIVE FORM

Facing page 71

In the year 1923, soaring flight freed itself from its dependence upon the Rhön, and became popular in many hill districts of Germany. But everyone was greatly surprised when the East Prussian Flying Association ventured to announce a Soaring Competition in Rossitten, which was carried out in spite of many difficulties.

Such spectacular achievements as those of the Rhön were not to be expected here. But the East Prussian, Ferdinand Schulz, an elementary school teacher, had demonstrated that soaring was feasible over low sandhills. Like the brothers Wright, whose work he may be said to have continued, he started from dunes, the greatest height of which does not exceed two hundred feet, and flew along them. He remained in the air for six minutes and attained an elevation of a hundred feet above his starting point.

In order rightly to appreciate his feat, it must be remembered that his machines were primitive in the extreme. He had built them himself, without suitable material, and overcame their technical deficiencies by his marvellous skill and tenacity.

Experiments were also made with a sea-glider, but the results were unsatisfactory. The important thing was the recognition of the district as good flying country, for the noteworthy successes achieved at Rossitten in later years were undoubtedly built up on the experiences of this first meeting.

Before the end of the year a flying meeting took place in England which clearly demonstrated the practical side of soaring, although the meeting was originally arranged for the purpose of promoting the development of aeroplanes with light engines. It proved a complete success, some marvellous results being obtained with machines carrying motor-cycle engines of from ten to 20 h.p. In certain machines, as for example the Handley Page aeroplanes, it was easy to trace the direct results of soaring flight; they were, in fact, merely soaring planes with an auxiliary engine. In other types, too, the influence of the experience gained from the designing and building of soaring machines was clearly visible. Great progress was made in the designs for lightly built machines, while considerable improvement was noted in steering gear.

We looked forward hopefully to 1924. Early in the spring things began to liven up. The Rossitten Meeting revealed the ardent enthusiasm and desire for new achievements that had developed during the winter.

The finest feat of this Rossitten Meeting was the duration feat made by Schulz, a man who has fought his way to the front in spite of all the obstacles attendant on his lack of technical knowledge and all the various resources which were at the service of the academic flying groups. His planes were so weak and primitive that they had been condemned at the technical tests applied to machines that were entered for the competitions of the Wasserkuppe the previous year. But here in East Prussia, his home land, Schulz was bent upon showing what he could do. He could not bear the thought that Germany had lost the record for duration flying, and so he flew for eight hours forty-two minutes and nine seconds in his old "Broomstick," thus breaking Maneyrol's world record. But the important factor of his feat was his demonstration of the possibility of great achievements with the very simplest resources.

His victory was not attained without a struggle, for he had formidable rivals in Martens, Hackmack, and Spiess, all of whom flew machines that were recognized as the best of their kind.

Once when Martens had flown over six miles he was compelled to descend in order to avoid crossing the Lithuanian frontier and thus creating official complications.

At this Rossitten Meeting experiments were also carried out with soaring planes provided with small auxiliary engines. Martens mounted a light engine, of five h.p. on his "Max," which proved sufficiently powerful to sustain the machine in an horizontal flight.

Still more notable was Budig's experimental plane, a small biplane on which various novelties were tried out. For example, Budig attempted to obtain automatic stability by utilizing the pressure on the wings (which varies with differing flight conditions) to create stabilizing surfaces. Budig employed engines of various h.p.'s, and though his flights were short, they were particularly

interesting on account of the accurate scientific investigations he always made when engaged on them.

The development of light flying machines with the lowest possible auxiliary engine power was made a special feature of the 1924 Rhön Meeting.

The shortest course for soaring planes in this competition was fixed at fifteen miles, with a minimum height of eleven hundred and fifty feet.

Comparatively few new types of machines were seen this year. Martens brought with him six machines; Espenlaub was there with an improved machine of his own construction, while naturally the successful planes of the previous year reappeared. Two machines of a new type are worthy of special mention, because they represented an attempt to obtain better facilities for flights in gusty weather by variable wing curvatures. One of these planes, which was constructed by Herr von Schertel, did nothing of note, but the other, the "Roemryke-Berge," won the second prize for distance flight; this was the machine in which Nehring made his wonderful record flight years later.

The achievements at this meeting were, however, so poor that even the most incorrigible optimists began to doubt the possibilities of further development in soaring, but it is only fair to mention the fact that out of the twenty-eight days of its duration twenty-five were foggy or rainy. There were no feats comparable with those of the previous years, the longest flight being the seven miles covered by Fuchs in the Darmstadt "Konsul," while in the "Alte Dessauer," the same pilot attained the greatest height of six hundred and sixty feet above the starting point.

The engine-driven machines did better. Udet, the celebrated stunting and war pilot, brought a splendid machine, the "Colibri" (Humming Bird), in which he made a beautiful cross-country flight, gained a prize for height, and finally succeeded in screwing up the duration record for machines with light engines to four hours and thirty-nine minutes. A very interesting machine was Bäumer's "Roter Vogel" (Red Bird), which was, in fact, an "engined" soaring plane that could soar equally well with or without its motor power.

All these experiments with motor planes only served, however, to show that the Rhön was not the right sphere of activity for them, and they were, therefore, eliminated from the competitions of following years. Flyers were far from satisfied with the results of this Rhön meeting.

It was thus quite natural that German pilots should look forward enthusiastically to the Italian Flying Meeting in the September of the same year, when they hoped to do some better flying than had been possible under the wretched weather conditions of the 1924 Rhön Meeting. But there further disappointments awaited them.

German soarers had been invited to this competition by the Italian National Air League, and a picked team set out under the leadership of Oskar Ursinus. They found that the starting place was on a mountain more than four thousand feet high, among shell holes and trenches of the former war zone. The first to start was Martens, who found it impossible to carry out anything but a gliding flight, and later the difficult starting and landing conditions led to many accidents. On one occasion the "Konsul" barely escaped a fatal crash after grazing a high tension wire with its wings. Martens smashed his two-seater "Deutschland" (Germany), while his record distance flight ended in a crashed landing. The Germans were not too well satisfied with this last achievement, in spite of the acclamations which it earned, as it was, strictly speaking, not a true soaring flight but rather an extremely skilful utilization of the enormous difference in height between the elevated starting point on the mountain and the valley below. The longest flight was thirteen miles.

At this period the interest in soaring flight began to fall off, as adherents of any cause invariably become lukewarm when they have no progress to point to and no new records to fire them. Consequently the pilots were not particularly hopeful about 1925, and their despondency proved to be fully justified, as the year had no special achievements to show. Its brightest and most important feature in connection with the future of soaring flight was, however, the appearance of new and young pilots. The Darmstadt student, Nehring, made his record flight of



17. THE QUICK-RELEASE OF ESPENLAUB'S SOARING PLANE

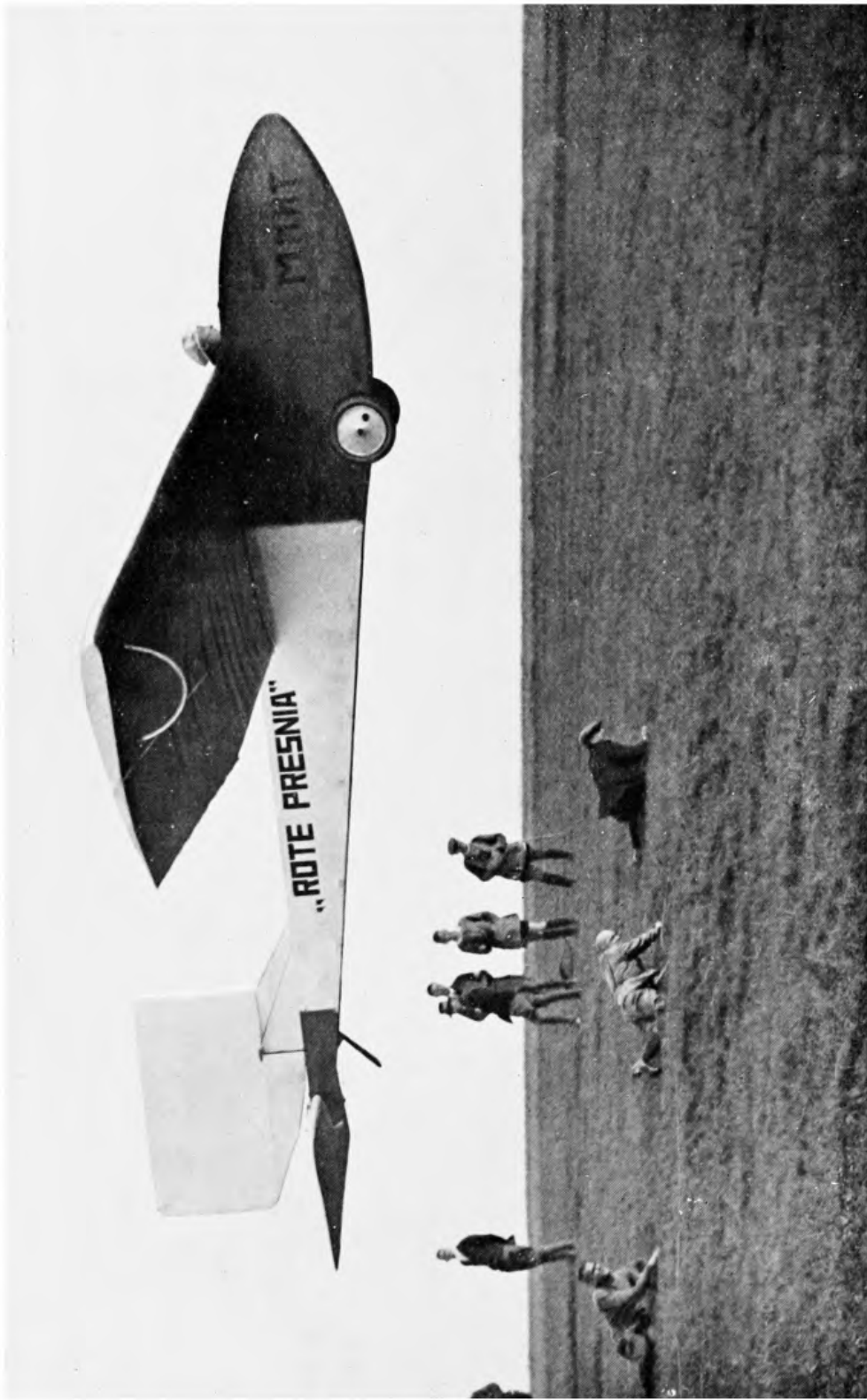

18. A RUSSIAN SOARER ON THE RHÖN IN THE 1925 MEETING. IT IS NOT GENERALLY KNOWN THAT THE SOARING FLIGHT MOVEMENT IS EXTREMELY POPULAR IN RUSSIA, WHERE THE CHIEF CENTRE OF ACTIVITY IS IN THE CRIMEA

thirteen miles, while his friend and fellow student, Hesselbach, broke the two-seater record with a flight of three hours five minutes and fifty-five seconds.

The only interesting soaring planes at this uneventful meeting were those of the Russians, who took part in a Rhön competition for the first time.

Following the example of Germany, Russia had held the first All-Russian Soaring Meeting in 1923. Russia contains much good flying terrain, and an excellent site had been chosen for this first meeting after a long and thorough search, in the course of which practically the whole land was explored. This was a stretch of land in the Crimean Mountains where, as the Russians said, the wind streamed up as though from an oven. Very few machines appeared, but much experience was gathered from the results of the meeting, and many technical faults were overcome. The steering surfaces of most of the machines were too small and had to be enlarged during the meeting, but on November 5th Jungmeister made a distance flight of one thousand seven hundred yards, and ten days later achieved a soaring flight in which he reached a height of three hundred and thirty feet. The following day this indefatigable flyer started again and flew for one hour two minutes and thirty seconds. There were several technical novelties, the most interesting being the parabolic plane which consisted of one vast parabolic surface.

And now the hard-working Russians were with us in the Rhön, and vied with the pick of the Germans in sporting spirit and flying enthusiasm. The way in which they "torpedoed" their planes untiringly, one after another, into the air was exemplary. They set a sharp pace. They even flew on foggy days when they could barely distinguish the outlines of the slope.

There was still much interest in the development of an aeroplane with an engine of low power that would be capable of soaring by its own unaided efforts. The "Karl der Grosse (Carl the Great), belonging to the Darmstadt Academic Flying Group, fulfilled these conditions so satisfactorily that the press devoted much space to descriptions of this new "Magic Flying Machine," in which the pilot

could fly with or without motor power at will. One of the best among the pilots who flew this plane was young Peter Hesselbach, who passed his Soaring Flight tests at this meeting in company with his fellow-student, Laubenthal. But no one then imagined that these were the men destined to demonstrate our soaring flying to the Americans at Cape Cod.

But in comparison with the previous years external triumphs were few, and much thought was given to the problem of how it might be possible to re-invigorate the movement. It was recognized that sportsmanship had brought us thus far, but other factors were needed for further progress. Up to 1924 new constructive work had been done, even though its inspiration dated back to the stimulus of the first meeting, but in 1925 no novelties appeared. There were not sufficient new pilots ; no new methods of soaring were discovered ; no new machines were brought forward.

In order to remove the first of these disabilities the Rhön-Rossitten Gesellschaft, which was founded in that year, acquired Martens' Flying School on the Wasserkuppe. The Institution for Research work which formed part of the school, and which possessed departments for the study of the technique of flight, aerodynamics and meteorology, was henceforth to devote itself to genuine scientific work in the field of soaring flight in addition to its original task of discovering new methods of soaring. In the following spring the new school at Rossitten was opened, and thus was established the predominance of the Rhön-Rossitten Gesellschaft in all matters connected with soaring flight.

The Rossitten meetings had always provided close-fought contests, and in 1925 a galaxy of soaring flyers entered. The best Rhön flights were not equalled, but Martens did some excellent work, including a distance flight of nearly nine miles. It must be borne in mind that in the Rhön a long flight of this nature can be accomplished purely and simply by a skilful glide from the Wasserkuppe down into the valley. In Rossitten, on the other hand, continuous soaring is needed if a flight of any distance is

to be carried out. A new feature of this Rossitten meeting was the successful night flying of Schulz, Martens, and the Darmstadt group.

The French meeting in Vauville, which took place almost simultaneously with the Rhön competitions, afforded a splendid proof of the enthusiasm and skill of the French and Belgian devotees of the new sport. That year they were favoured with excellent weather. The Belgians broke Schulz's record of the previous year twice, Major Massaux remaining in the air for ten hours and nineteen minutes, and Lieutenant Demblon for ten hours. The Frenchman Auger climbed before a thunderstorm to a height of two thousand three hundred and seventy-six feet, but his flight could not be recognized as a record because he had not complied exactly with the rules governing the registration of records. It was, nevertheless, a splendid feat. At that time, however, flyers had no clear knowledge how they might best utilize the energies of the thunderstorm, and several years were to elapse before they acquired it.

On the whole that year's French meeting was most successful, although it was somewhat clouded by the fatal accident to the Belgian pilot, Simonet.

The German flyers were invited to an autumn meeting in the Crimea and warmly welcomed the opportunity to show what they could do, the more so as their home results for the year had been so mediocre.

The Russians who were with us in the Rhön had much to say about their splendid flying region, and we found that their enthusiasm was fully justified. Excellent upwind was supplied by a mountain ridge three miles in length, with slopes of from five hundred to six hundred and fifty feet high. At his first attempt Schulz flew five hours and fifty-one minutes, but the next day the Russian, Jakobtschuk, achieved a flight of nine hours and a half. This spurred on "Uncle Ferdinand," who arrived at the starting place early in the morning of the following day armed with three sandwiches, a pocket lamp and his native obstinacy, and brought off a characteristic flight of twelve hours six minutes twenty-five seconds, of which over an hour was flown after night. In the course of this flight he also

established a height record of one thousand three hundred and forty feet. Then, inspired by the Master's example, young Nehring, who had already distinguished himself in the Rhön, started in his "Konsul" on one of those distance flights for which he had shown great aptitude, and on this occasion his performance was truly masterful. For the first time he worked his way systematically from hillside to hillside, making the most of every foot of height and planning out his course carefully with regard to the lie of the land. A distance flight of twelve and a half miles was the result, but the most noteworthy feature was the fact that the landing place was higher than the starting point. Nehring had made the first long distance flight in which height was not lost.

A great storm brought the Russian meeting to a premature end. More than thirty Russian planes and seven German ones were housed in tents pitched at some distance from the place where the competitors were accommodated. The tents were guarded at night by a few Russians, but one night towards the end of the meeting a whirlwind tore across the country. Its onslaught was so sudden that it was impossible for the watchers to summon help, and when the pilots went out next morning to investigate the damage they found the camp a mass of ruins. All the Russian tents and machines were destroyed, but the German tent still stood erect, with all its planes intact! With inimitable good comradeship the Russian sentinels had devoted their energies to the preservation of their guests' property.

ON THE WAY TO SCIENTIFIC FLYING

IN soaring flight circles, 1925 is often termed the year of crisis. It is noteworthy that in nearly every land where gliding and soaring flight was taken up, the interest in the new sport rose rapidly and fell again with equal rapidity. For example, no permanent results were achieved by the successful English meeting; in France, too, the movement soon came to a standstill, while in Germany things were hardly better. Then came science and helped us over the dead point.

Early in 1926 Professor Georgii was called to the Chair of Flight Meteorology at the Technical College in Darmstadt, where he entered upon his duties on May 1st of that year. At the same time he was nominated director of the Research Institute of the Rhön-Rossitten Gesellschaft. His appointment to these two offices brought about a close connection between the practical work of the company and the academic studies of the College, with the result that the Research Institute on the Rhön became the workshop of many young students who devoted their holidays to flying and other kindred sciences.

Science helped soaring, and soaring helped science. This, of course, had always been the case to a certain extent, but the twofold appointment, coming as it did just at that time of depression and of crisis, proved to be of decisive importance. In Professor Georgii German soaring flight found a scientific leader who was capable of helping it over many difficult moments.

The previous year's results had shown that the movement suffered from lack of concentration. For this reason the coastal Flying Meeting at Rossitten was reluctantly abandoned, while the time allotted to competitive flying in the Rhön was severely curtailed. The prize money was likewise concentrated on fewer events.

A complete novelty was introduced in the form of

experimental competitions with the aim of stimulating constructive creativeness and developing technical progress. Some time before these competitions opened, announcements appeared in the technical journals, calling on all persons who believed that they could contribute to the development of flying by bringing forward new ideas and problems to submit their suggestions to a special Research Committee. Among the mass of chaff received, most of which consisted of idle fantasies resting upon no practical foundation, were found a few valuable grains capable of being used as the seeds of future development. The Darmstadt Group's "Hessen," a plane which had not been sufficiently tested in the preceding year, attracted great attention by reason of its variable wing curvatures, which its inventors claimed as factors that would enable it to fly at both faster and slower speeds than had hitherto been deemed possible.

The indefatigable Espenlaub appeared with a plane furnished with a span of nearly eighty feet, which unfortunately did not fulfil the expectations of its creator owing to aerodynamically faulty designing. There were also two experimental planes which could beat the air with their wings and an interesting model of a helicopter.

In any case the entries for this new prize showed us that a valuable stimulus might be given to technical research by such a competition.

The sporting side of the meeting was also a great success. The young flyers went industriously to work; the old brigade "kept its end up."

A noteworthy feature of that year was the way in which the pilots contrived to render themselves comparatively independent of the weather, and still more worthy of special attention was the masterly flying technique which Nehring now displayed for the first time, which can only be described as truly scientific. Kegel's somewhat unintentional utilization of the energy derived from the movements of free air was another phenomenon of an interesting nature.

It was Ferdinand Schulz who initiated the practice of starting out in atrocious weather and incited the others to fly even in rain and hail. But far more important were the

flights suggested by Professor Georgii and carried out by Nehring ; these were carried out in quite light breezes by the aid of currents engendered purely by heat. When Professor Georgii urged on the flyers the necessity of endeavouring to fly on windless days, deriving their motive power solely from the warm air rising from the valley, most of them refused. " It will only mean," they said, " flying down into the valley and then having to transport the plane back all that way up the mountain." Nehring alone made the attempt, but with wind velocities of only three or four feet per second he contrived to attain to a height of three hundred and thirty-three feet above his starting place.

Nehring revealed himself as a true master by his flight to Milseburg and back. When he had reached the mountain which was selected as the goal (at a distance of about three and a half miles from his starting point) he began to lose height rapidly. After careful consideration he flew to a slope above a gorge in which the wind was driven upwards as if in a shaft. Here he succeeded in regaining his lost elevation, but nevertheless afterwards dropped to some four hundred feet below the starting point. The spectators who were watching from the Wasserkuppe were convinced that he could not recover his lost height, but by skilfully making the best of his situation he succeeded in doing the impossible and climbed so far that he actually contrived to land at an elevation higher than that allowed him by the conditions of the flight. On this occasion Nehring demonstrated in wonderful fashion the true significance of slope soaring, for he did not call upon chance to aid him but made a carefully calculated plan in accordance with the prevailing wind and land conditions.

Fundamentally different, though also most interesting, was Max Kegel's distance flight. On August 12th he was surprised in the air by a thunderstorm which had gathered with unusual suddenness. Landing was impossible ; for a moment he disappeared into the clouds. He had no clear conception of the meteorological processes which lead to a thunderstorm, such as the cold air which inserts itself under warm air, thus flinging it up into a " thunderstorm front " and forming a roller of clouds from which issue

lightning and rain. To take advantage of the storm, the pilot must fly along the front of this roller ; Kegel did not contrive to do this, but he was flung so high by the strong upwind that when he had happily escaped from the clouds he was able to make a long gliding flight of over thirty miles. As he had no barograph with him, he could not determine accurately the highest point he reached, but it must have been at least two thousand three hundred feet higher than his start.

Kegel's description of his terrific struggle with the storm was so eloquent that everyone was strongly dissuaded from imitating his example, and in the following year flying experts pointed out that it was most inadvisable to attempt thunderstorm flying.

1926 was again a year of records. The flights of Nehring and Kegel had convinced many sceptics that good soaring demands a profound knowledge of air currents and their laws and that we still possessed all too little of this knowledge. An acute observer must have sensed the dawn of a new era in soaring.

With his usual tenacity Ferdinand Schulz refused to let 1925 pass without the accomplishment of some special feat in his homeland. On June 3rd, some time before the opening of the Rhön Meeting, he created a world record for two-seaters by remaining in the air above the sand dunes of Rossitten for nine and a half hours with a passenger. This fine flight must certainly have helped to prevent interest in Rossitten from dying out, and the Rossitten Meeting in the spring of 1927 showed how important it was that it should be kept alive.

Max Kegel had added an engine to his thunderstorm machine, and hummed about the district in his new-fangled nine h.p. aeroplane, thus wiling away some dull hours ; not that there were really many of those during that meeting. Coast land is and will always remain the best territory for duration flights on account of the steady winds and areas of strong upwind. Ferdinand Schulz was naturally once more to the fore in these achievements ; on May 3rd he made a flight of fourteen hours and seven minutes in his " Ostpreussen " (East Prussia). Nehring and

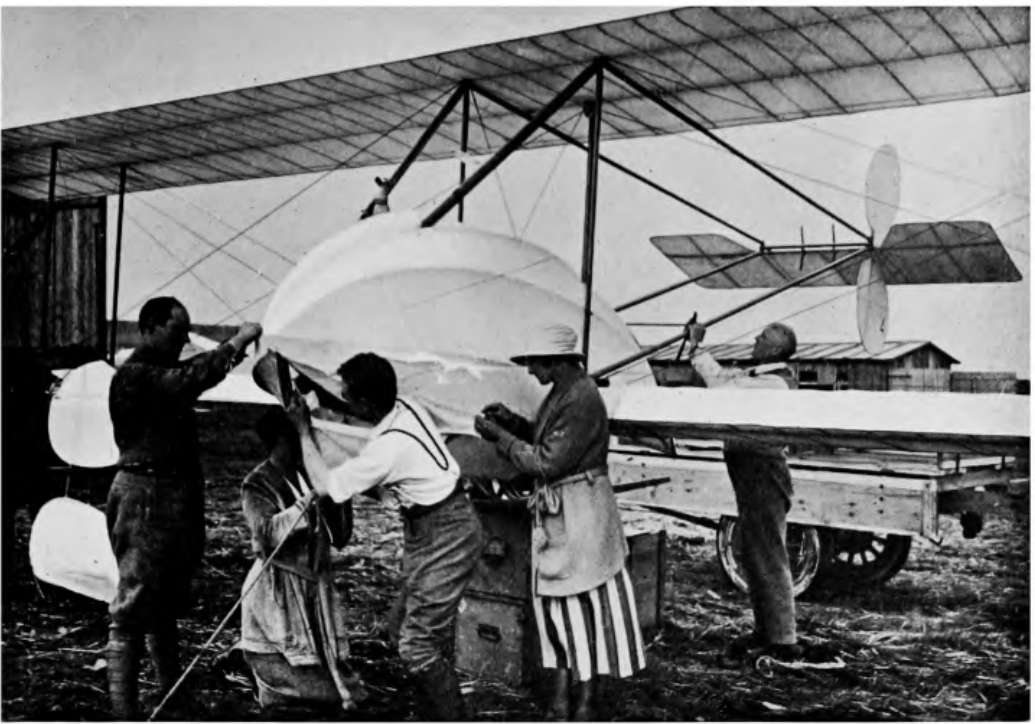

19. THE FAMOUS AIRCRAFT DESIGNER, FOKKER (LEFT), WHO WAS ONE OF THE MOST ENTHUSIASTIC DISCIPLES OF SOARING FLIGHT, AT A RHÖN MEETING



20. SOLDENHOFF'S TAILLESS MOTOR-PLANE. BUILT AND FLOWN BY ESPENLAUB, THE WELL-KNOWN SOARING FLYER

Facing page 82



21. THE WASSERKUPPE DURING THE 1926 COMPETITION

Reidenbach flew together in the two-seater "Margarete" for five hours and fifty-five minutes.

Far more interesting, however, were the distance flights, which were specially remarkable feats because the sea dunes over which they were made seldom rise to a greater height than thirty-three feet. Schulz worked his way along these insignificant hillocks and succeeded in reaching Memel, which lies somewhat over thirty-six miles away. Often his wing slid along a hair's breadth above the dune when he was trying to utilize some solitary gust to gain height, while his method of bridging gaps between the slopes which he had to cross was simply masterful. The upwind area is often so narrow that it is difficult to keep aloft a machine of any considerable span, and frequently he had to fly over the heavy Baltic surf, where there was no possibility of landing. His sporting spirit and marvellous skill overcame all difficulties.

It was almost even more amazing to watch Schulz rise to a height of over one thousand six hundred and fifty feet above the dunes. In the Rhön Hentzen's 1922 height record had not yet been surpassed, but here, on these low slopes where it was least to be expected, such a height had been attained.

Young Nehring did not hesitate to attempt to rival the older master's feats in this territory that was unfamiliar to him. As usual, his sporting feats were enhanced in value by the interesting observations he made. He pushed out to sea for a distance of three hundred and thirty feet and established the fact that very heavy surf causes upwind, but his greatest feat was a flight over the seaside resort of Cranz. There is a gap in the dunes a mile and a half long, this flat area being occupied only by low trees, strand pavilions and hotel buildings. But Nehring was not deterred, for he found out that even the houses and trees could supply him with sufficient upwind, and, as a matter of fact, he attained his greatest height directly over the people who were strolling on the beach below.

Science has given us the explanation of these remarkable phenomena. In such cases the upwind is not produced by the objects in question but by the check such houses

and trees give to the air currents streaming in from across the sea. Eddies are formed, over which the aircurrent must climb, and in it the flyer soars.

Thus Rossitten also demonstrated the value of the union of practical and theoretical work and pointed out many new paths. But if the possibilities of the Rossitten country were most fully exploited by Ferdinand Schulz, Johannes Nehring had now become the master of the mountainous Rhön, and in the eighth Rhön soaring competition he showed us what he could do.

The meeting was once more a great success, as is proved by the fact that competitions took place for all the prizes that were offered. To promote the new developments, prizes were offered for proficiency shown by pupils, for the best courses of training and for all-round achievements. The first was to serve the purpose of attracting a succession of younger gliders ; the second was to ensure good training of the " C " pilots, that is to say flyers who have passed their final Gliding and Soaring Flight Examination, while the Achievement Competition was intended to encourage the most efficient forms of flying, to create new flying possibilities and to stimulate " Record " pilots to surpass their previous feats.

The desired results were obtained. Although Nehring's distance flight was shorter than some flights of the previous year, such as those of Schulz (in Rossitten) and Kegel, it proved their equal as a fine piece of flying. When judging distance flight it is always necessary to take into account how and under what circumstances they are carried out. Starting from the Wasserkuppe, Nehring flew a good thirty miles as the crow flies, but they were forcibly wrested from the slopes in the most literal sense of the word. There was no thunderstorm to bear him on high, no coast land with its even contours ; he was constantly seeking out new fields of upwind, struggling against downwind, thinking, calculating ; in short he made a masterful flight. His barograph shows clearly how continuous was his struggle to maintain the necessary height.

Still more masterful was the way in which Nehring won the prize offered for a goal flight to the Heidelstein and back.

The distance from the starting place to the goal was nearly five miles, and the hillsides along which he had to fly there and back are most unfavourable. It is therefore not possible to carry out this flight by ordinary methods. But Nehring did not hesitate for a moment; after cool calculation he flew some distance beyond the goal, sought out a slope which did not lie directly in his course but which had good upwind and lingered there until he had gained sufficient height to fly gracefully back in a long curve right round the Heidelstein. Once on the return flight it seemed as if he must drop down to earth, but again he looked for a favourable slope and landed not far below the starting point, thus displaying extraordinary air-sense in the way in which he coped with the prevailing conditions.

Kegel, too, had a very fine flight to his credit. At that time the state of the German soaring movement was such that its friends were constantly on the lookout for new methods of preventing it from coming to a standstill. A goal flight was therefore announced when the wind was blowing in a direction which had hitherto rendered long flights impossible. Following the example set by Nehring in the previous year, Kegel utilized the prevailing conditions to the fullest extent and carried off the prize.

One special feature of that year's flying was the immense gulf that separated the masters from the younger men who aspired to be their successors. Apart from Nehring, Schulz, and Kegel, no one showing great ability was to be seen, all the other pilots falling far below the standard of these three. The Munich youth, Thoenes, attempted the Heidelstein flight in his "Münchner Kindl," and reached the goal without much difficulty, but on the return journey he crashed on rocky ground and was indeed fortunate to escape without injury.

Nevertheless the general results of that year's meeting were very satisfactory. Sixty-eight planes had appeared (a sure sign of interest) and five hundred and fifty flights were made—twice as many as in the previous year. But now the criticism which is always helpful to progress began to appear. What was to be the next step? Nehring's slope soaring had pointed out many new possibilities which

were assuredly open to further development. He knew his flying area well, and it was to be presumed that skilful handling of his machine would enable him to add on a few extra miles—but only a few. The Rhön district had already been thoroughly flown in all directions along lines radiating from the Wasserkuppe as a centre, down almost to the plain where a wide landscape without hill or mountain stretched to the far horizon. Not much more was to be expected from slope soaring, and consequently the coming year was looked forward to with much interest and some anxiety.

But before the flyers met again in the Rhön, new and exciting developments took place in the spring of 1928. Two expeditions from Germany to foreign lands were organized and carried out.

America, the land in which motor flying had been developed from the gliding and soaring experiments of the brothers Wright, seemed almost to have forgotten their work during the period in which engine-driven flight had made its way so rapidly, but there were some Americans who still followed with interest the progress of soaring in Europe. They desired to see young America waken up to the interesting possibilities of soaring sport, and a German-American, Mr. Fröhlich, of the North German Lloyd, was eager to arrange for a visit of German soarers to America. The American Motorless Aviation Club was founded and three German soaring pilots were invited to visit America and give practical demonstrations of gliding and soaring. The leader of the expedition was Captain Röhre, the Director of the Rossitten Gliding and Soaring School, and with him went two members of the Darmstadt Academic Flying Group, Peter Hesselbach and Laubenthal. They took with them the "Darmstadt," the fine machine in which Nehring had made his best flights, which was now destined to show its capabilities in the hand of a skilful pilot on the other side of the ocean. But first of all the expedition had a long search through the vast land for a place suitable for their demonstrations. This was found at last at Cape Cod; there were still many difficulties to overcome, but finally, on July 26th, the first good soaring



22. NEHRING, A VERITABLE MASTER IN THE ART OF SLOPE-SOARING. HE CRASHED TO HIS DEATH IN A MOTOR-PLANE IN 1930

Facing page 86



23. THE DARMSTADT ACADEMIC FLYING GROUP'S D.18. FUSELAGE AND WINGS SHOW THE EFFECT OF THE EXPERIENCE GAINED IN SOARING FLIGHT



24. THE DARMSTADT ACADEMIC FLYING GROUP'S "MOHAMED," A TYPICAL DESCENDANT OF THE SOARING PLANE FITTED WITH A LIGHT ENGINE

flight was made. It lasted for fifty-eight minutes and enabled Peter Hesselbach to break Wright's old record.

And now this great country, which is always so enthusiastic for sporting feats, began to bestir itself. When, three days later, the young pilot from Darmstadt broke his own record with a flight of four hours and nine minutes, his achievement was welcomed with acclamation. But records were not the sole aims and objects of the expedition ; the most important problem was how best to pass on to others the accumulated experience obtained at home, that might save them from going astray on many wrong paths at the beginning. Through much mutual understanding and camaraderie there grew up that German-American co-operation which was to bear such good fruit later and which had left as its memorial the Cape Cod Flying School.

In this spring France also announced another great international flying meeting. The two Frenchmen, Auger and Abrial, had been in the Rhön in 1927, where both had been popular. Abrial's sportsmanship and tranquil, helpful temperament had especially endeared him to his German colleagues. These two procured an invitation to the German pilots to take part in the competitions.

The meeting took place on the old, familiar slopes of Vauville. The conditions there, especially as regards wind and weather, are very similar to those at Rossitten, with the additional advantage of a vast drop of five hundred feet towards the sea which supplies splendid upwind, but one serious drawback was the difficulty of finding good landing places on a coast where the surf breaks directly upon the cliffs of the different capes.

Five German planes arrived, but only two French ones. Abrial's "Vautour," piloted by Auger, was too heavy for the light winds which prevailed during the competition, while the "Hirondelle," which was piloted by its designer and constructor, Savoya, reminded us of many failures which appeared in the Rhön in 1920. It was entirely unsuitable for competitive flying, so that the meeting resolved itself into a German competition under French management.

The greatest height was reached by Hirth in the "Württemberg," designed by Laubenthal. The chief interest,

however, centred, as usual, around the distance flying. Nehring, who was the first to fly for the distance prize, started in a wind with a velocity of twelve feet per second, rounded a difficult cape and landed after a flight of fifteen miles, a daring exploit in view of the light breeze and the unfamiliar territory. In his next attempt he did not succeed in rounding the rocks of the cape and had to make a forced landing on rough ground where a crash was inevitable. Hirth had learned much from these flights ; realizing that the wind was held up within the bay and that the true upwind began to rise from the water far out at sea in order to pass over the aerial dam, he endeavoured to escape Nehring's bad luck by flying right out to sea. He rounded the dangerous point in splendid style close above the spray of the surf. After negotiating a difficult cape, he finally landed on the beach of a seaside resort more than seventeen and a half miles from his starting point. This feat should not be undervalued, as it calls for more pluck on the pilot's part to experiment with a new course over the sea where failure means a descent into the waves than it does when he is flying above solid ground where he can always find a landing place in an emergency. To attempt the former expedient a man must have immense faith in his theory.

There was no one who did not rejoice in the victory of this comrade who was so universally beloved. Wolf Hirth, one of the pioneers in the early days of the Wasser-kuppe, is unsurpassed in his devotion to soaring ; in spite of several bad crashes which kept him in hospital for long periods he returned again and again to his favourite sport ; not even the loss of a leg in a motor-cycle accident deterred him from flying, and such is his tenacity that the greater number of his successes have been gained since his disablement.

During this French meeting the other machines also did good flying under the guidance of their expert pilots. Kegel's plane, in particular, made many fine flights, and it is hard to say whether the Germans had more pleasure in their successes or in the exceedingly hearty welcome and co-operation that they found in a foreign land.

In the meantime matters were by no means at a stand-

still on the Wasserkuppe. The staff of the Technical Department of the Research Institute had been working indefatigably for years, and undoubtedly their most interesting experiments were those made with new machines of the tailless types and the "Duck." It is known only to the few initiated that the first experiments with a new propulsion force for aeroplanes, i.e. the rocket, were made with soaring planes. After numerous tests with models propelled in this fashion the experimenters proceeded to equip the "Duck" with a rocket apparatus. The few people in the secret had followed this experiment with lively interest, the more so as at one of the later trials a model attained a speed of three hundred miles an hour. It is obvious, of course, that these tests had to be conducted with the maximum of caution, but on June 11th, 1928, Herr Stamer, the director of the Flying School of the Rhön-Rossitten Company's Research Institution, made a flight of eighty seconds in a rocket plane constructed by Alexander Lippisch, in the course of which he described a complete circle.

Hissing violently and emitting an immense volume of smoke, the plane shot forward without any difficulty, but at the second attempt matters did not progress so smoothly. The start was a good one, but a few seconds afterwards the rocket exploded with a report like that of a bursting shell. The nine pounds of explosives contained in its metal sheath were scattered far and wide, incidentally setting the plane on fire. Herr Stamer went into a dive to extricate himself from the flames, and landed in the nick of time with two large holes burnt in the back of his coat.

Thus ended the first attempts to pilot a machine propelled by a rocket. The experiments were carried on in all secrecy, so that the only modest record of Herr Stamer's wonderful feat is his "Rocket Coat," which has been preserved in memory of the perilous day.

OUR EFFORTS REWARDED

AND now the days of the ninth Rhön Soaring Meeting draw nigh. The entries for all events exceeded those of any previous meeting—a tribute to the growing interest in soaring—and whereas on previous occasions the outstanding feats were performed by a few experts, this time every prize was keenly contested. Above all, the younger generation began to make its presence felt.

The enthusiasm of these young folk was shown by the record number of entries. A hundred and five planes were entered, and nearly all of them appeared. The new and vigorous life infused into the soaring movement this year is best demonstrated by the fact that it witnessed the breaking of the Rhön duration and height records which had stood intact since 1922.

In the July of that year I was fortunate enough to break Hentzen's endurance record of three hours six minutes with a flight of three hours twenty minutes. His height record was surpassed no less than eleven times—by several pilots.

Although, as I have previously remarked, duration flights as such can hardly be considered an important phase of expert flying, they are, as their name implies, excellent practice for all flyers. This time the contest for the endurance prize was fought out with the utmost obstinacy; on August 9th Pomnitz broke my Rhön record with a flight of four hours seven minutes, only to be vanquished on the same day by Dittmar, who flew for four hours twenty-two minutes. Finally, on one of the last days of the meeting, I succeeded in recapturing the record with a flight of seven hours fifty-four minutes.

As it had not been possible to calculate the exact height reached by Kegel in his thunderstorm flight of 1926, the old 1922 one still stood. It was no mere matter of chance that 1928 saw it broken.

The most important novelty in this competition was the systematic utilization of what is known as cloud upwind, i.e. the air currents rising under cumuli. As I was instrumental in developing its technique, I think it will not be out of place if I take up the tale and give my readers a direct account of my experiences.

In the spring of that same year the upwind under cumuli had been the subject of experiments carried on by the Research Institution of the Rhön-Rossitten Gesellschaft above the flying ground in Darmstadt. Professor Georgii reported to me that Nehring had succeeded in keeping up close under clouds for a considerable time without loss of height when flying a light-engined aeroplane. He had even contrived to do so with his engine shut off—a feat which promptly roused in me the desire to try the same experiment with a soaring plane.

On the day of the first big Cloud Flying event I went up without any special ideas about cloud flying but with a hope of breaking the duration record. But duration flying is such monotonous work that the pilot must always look out for something to distract his mind if he is to keep awake, and this time I concentrated my attention on the fact that my plane climbed every time a cloud drifted over the summit ; when, therefore, I saw a gigantic one drawing near, I resolved to try to gain contact with it. Even then I realized that the chief difficulty in cloud flying was that of obtaining contact at the right moment. But my very first attempt was a success, and soon I found myself nearly one thousand four hundred feet above the starting place, travelling with the cloud. At first I flew on purely on account of my interest in the new phenomenon, but at last I began to wonder, while still circling under my cloud, whether the aid of this new method of soaring would enable me to fly round the Himmeldank Mountain. Now with the wind in the direction in which it then was I could have reached this mountain, but I could not have managed to fly back from it by our usual methods of slope soaring. I therefore pushed away from the cloud just as it drifted obliquely past this goal, dropped down to the hillside and maintained myself in the upwind there for a long time

Although many of the spectators on the Wasserkuppe could not make out what I was trying to do, I had already began to hope for great things from my new experiences.

And so I hung above a slope on the Himmelbank Mountain, patiently oscillating like a pendulum, while a cloud which I had noticed far away a little while before drew slowly nearer and nearer. I thought that I could only succeed in flying back to the Wasserkuppe by the same means which had enabled me to perform the outward journey, but I was beginning to feel by no means too sure of my theories. Then Max Kegel ("Thunderstorm Max") started from the Wasserkuppe and soon joined me over the Himmeldank Mountain, but as I had already been pottering about there for quite a long time, his height was greater than mine and he turned at once in order to get back before me. That was a critical moment; I was fully convinced that the Wasserkuppe could only be reached in this wind by the help of the clouds, but none the less it needed great confidence in my new theory to refrain from turning and hastening to join Kegel on the return flight. I became, however, more content to remain where I was when I saw that he was gradually losing height. At last he encountered the downwind of the Wasserkuppe and was compelled to land deep down in the valley and far away from the starting place.

In the meantime my new cloud had drawn so near that I expected every moment to feel its upwind. Suddenly I was in it, just as I had been in that of the other cloud when I started from the Wasserkuppe. All at once the plane rose rapidly, so that in a very short time I found myself again under the base of the cloud. It was evident that I had grasped instinctively the right way of getting into contact. To avoid forging too far ahead of a great cloud, you must keep on circling beneath it, and if you cannot manage to spring across to the next one, your speed will be exactly that of the prevailing wind velocity. Luckily I found for my return flight this time a continuous highroad of clouds stretching from the Himmeldankberg to the Wasserkuppe. Under this I proceeded in a straight line back to the starting place flying almost directly against the wind,

From time to time I turned out of my course in order to discover where the most favourable upwind fields were to be found. I was so high above the mountain tops that there was no danger from the Wasserkuppe downwind ; consequently I attained my greatest height of one thousand seven hundred and eighty feet on the homeward journey, dropped down from it in a spiral glide and settled to a hair's breadth on the spot from which I had started.

I was received on the Wasserkuppe with cheers and congratulations, for just this last part of the flight had shown everyone the vast difference between Nehring's last year's distance flight and that which I had just concluded. Nehring had adopted his flight to the formation of the land in the most masterly way, while I had paid hardly any attention at all to it. This was the first step from the old method of flying from slope to slope to the new one of flying from cloud to cloud.

Not many of the flyers present realized at once what I had done ; only the few who had watched the flight closely had drawn conclusions which they proceeded to put into effect. Thus Bachem was the second to fly to the Himmeldankberg and back, though he contented himself with attaining by the help of the clouds a height of two thousand one hundred and seventy-eight feet shortly after his start and then making use of this elevation for a gliding flight which carried him round the goal and back. He had no need to seek further assistance from the clouds on the return flight.

These flights undoubtedly laid the foundation for the development of cloud soaring, though the practice did not become general until the following year, when distance and height records were gained by its means, and its usefulness thus demonstrated.

Professor Georgii expressed himself on the significance of cloud flying for soaring flight as follows : " Kronfeld's is the credit of having been the first soaring flyer to make use of this upwind, which is entirely independent of the slope upwind which soarers have hitherto employed. On his flight to the Himmeldank Mountain he employed these new tactics so systematically and skilfully that the significance

of cloud flying immediately became so obvious to every soarer that during the further course of the competition all the pilots strove to gain contact with the clouds. The large number of high flights and notable distance flights made with help from the clouds before the end of the meeting proved that this contact was comparatively easy to attain and that splendid results might be expected from this new method of soaring. Undoubtedly cloud flying has placed soaring flight upon a completely new basis, which opens up further great possibilities for the future."

That same year I had a further opportunity to demonstrate another beneficial aspect of cloud flying. I was flying for the prize offered for the exploration of a district, and flew for twenty-four and a half miles through a stretch of land entirely unknown to flyers. My course led me for the most part above downwinds or over absolutely flat country where no upwind was to be expected ; the only way of crossing this gap was therefore to attach myself to a cloud and drift along with it. The second in this event was Ferdinand Schulz with a flight of twenty and a half miles, which he made by means of slope soaring. The conditions of this competition, I might say, demanded a minimum distance of fifteen miles, most of which was over country where no flyer had hitherto penetrated.

Although at this same meeting Dittmar achieved his Rhön height record of two thousand five hundred and seventy-five feet by the aid of cloud upwind without any clear comprehension of the phenomenon that had aided him, the duel between slope and cloud flying methods had apparently not yet been fought to a finish. Nehring's splendid distance flight, the longest hitherto made by any soaring plane, was evoked as proof of the superiority of slope flying by its supporters. Traversing the same terrain as in the previous year, he succeeded in adding twelve miles to his record, and thus established a new world record of forty-two and three-quarter miles. He also attained far greater heights over particular localities that year, which proved that he had increased his capacity to take advantage of the upwinds of a given area. When he had left his last point of support in the mountains, the front

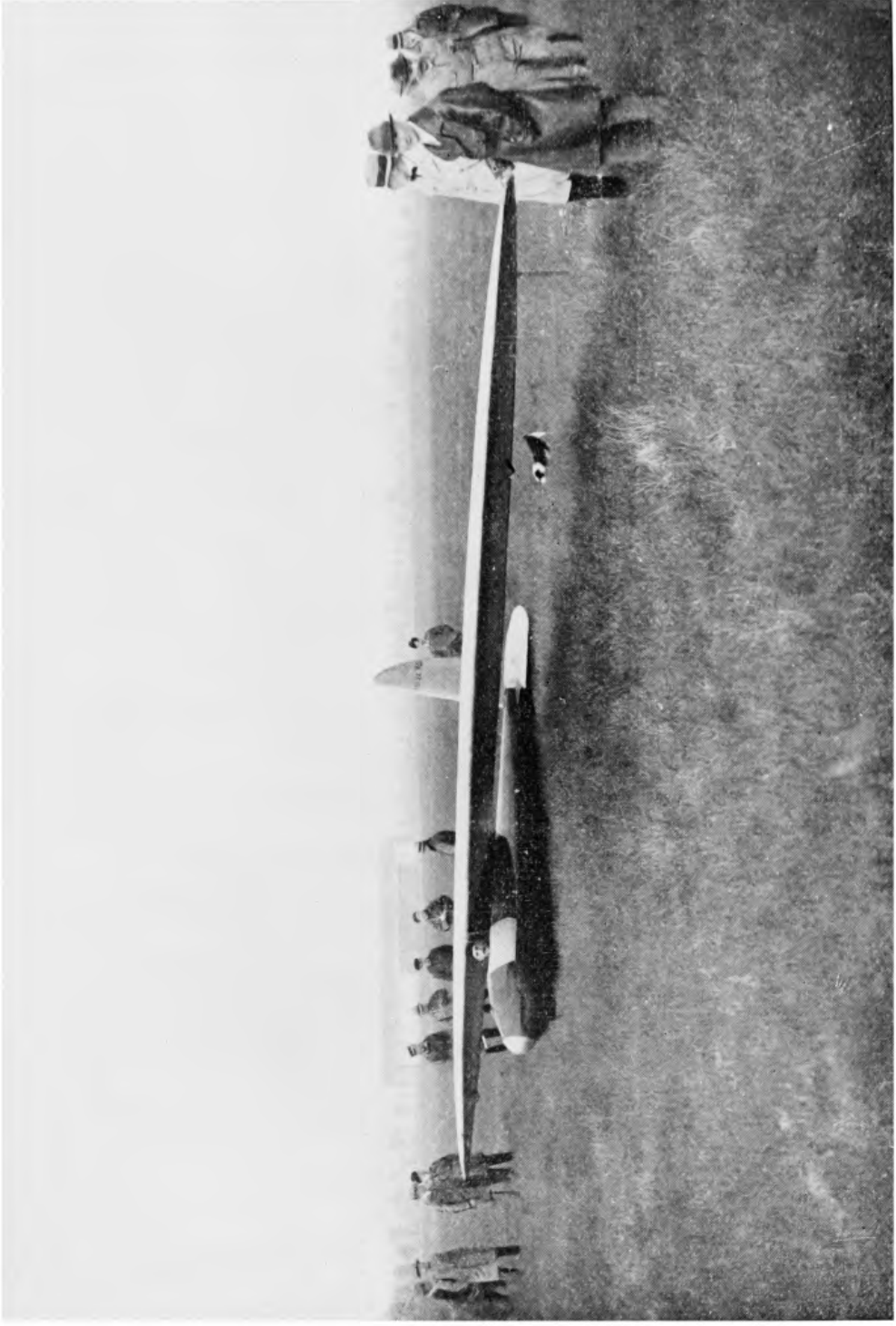

25. THE "RAPACE." A FRENCH SOARER DESIGNED BY ABBIALAND BUILT BY LOUIS FEYRET, WHO ALSO TURNED OUT THE MACHINE ON WHICH MANEYROL ACHIEVED HIS SUCCESSES
Facing page 94



26. THE "DUCK"
The Property of the Rhön-Rossitten Gesellschaft

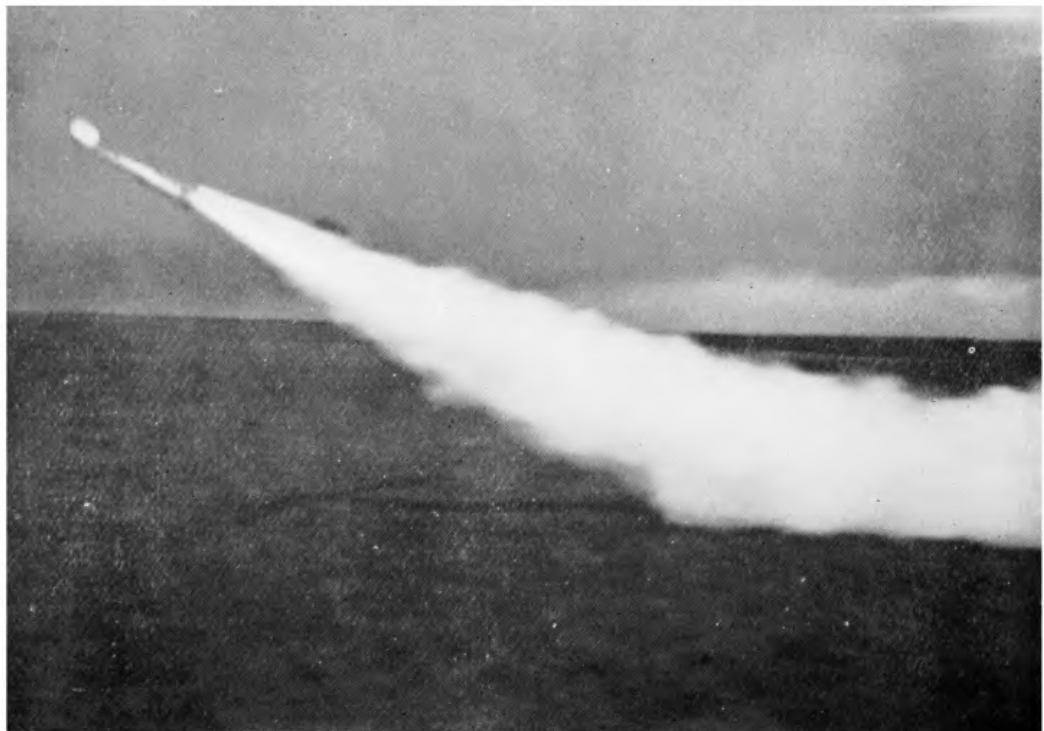

27. A TAILLESS ROCKET MODEL TAKING OFF

Facim: page 95

of an approaching gale came to his aid, enabling him to fly over his landing place of the previous year at a height of six hundred and sixty feet and thus gain contact with another hillside. His journey over so large a tract of country by means of slope flying was undoubtedly a masterly display of expert air-sense, but unfortunately it was impossible to increase the distances flown by this method, in the Rhön district, at least. The Rhön mountains are surrounded by plains from which not even the smallest slope rises, so much the more must we appreciate Nehring's skill in taking advantage of the tiniest hillock.

This competition yielded great results for soaring flight. Moreover the young pilots who took part in the training competitions were most energetic, especially Krause, of Berlin, who put in an aggregate flying time of seven hours seventeen minutes fifty-eight seconds. But the greatest value, however, must be attached to the new methods of flying which were demonstrated for the first time, on account of the stimulus they gave to later special flying achievements. Taken as a whole, this competition may be fairly called a record one. The number of the competitors, planes and flights all exceeded the respective figures of the previous year, while the standard of efficiency was undoubtedly superior to that shown at any of the earlier meetings.

Then came autumn and winter, when soaring hibernated. Only in the Alps was soaring research still carried on.

Many starts had already been made from the edges of precipices, but nearly all of them took place in calm weather, while the higher peaks still remained virgin soil for soaring research. Udet, the celebrated stunting and war pilot, had made one flight from the summit of the Zugspitze (nine thousand seven hundred and seventy-eight feet), in the course of which he glided down into the valley below, but he was not able to do any soaring.

An expedition was arranged to the Rax Alp for the purpose of investigating the air current conditions, and the possibilities of soaring over steep slopes and precipices in the High Alps. As high mountains present special obstacles to the development of flying traffic, there is obviously a necessity for a careful investigation of the laws

which govern upwinds and downwinds and their intensities in those regions.

I was called upon to execute a number of flights under exceedingly difficult conditions. The first of these were three long gliding flights, the object of which was to ascertain the possibilities of flights from the edges of precipices in motorless machines and the limits of the advisable proximity to the precipice walls. Especially interesting was a flight in the "Prüfling," in which I succeeded in flying right out over and away from the rock-wall in a dead calm and without any appreciable loss of height. As we cannot count upon warm currents in winter in the neighbourhood of even medium-sized mountains, this flight, which was only rendered possible by the help of a warm upwind, gave us valuable statistics concerning the prevailing intensities of upwind currents engendered by thermal conditions in the mountains. The first soaring flight in the High Alps, which took place in the course of this expedition, was something quite new in the annals of flying. It was carried out on February 12th, 1929, and lasted for half an hour in a wind velocity of fifty-one feet per second and a temperature of thirty degrees (centigrade) of cold, but we were able to land again on the plateau at the top of the precipice. This expedition proved the possibility of making such investigations in the high mountains by means of soaring; it also brought back much information that proved to be of practical value to the pilots of engine-driven aeroplanes. Our observations of the formation of eddies were most interesting; the strength of these eddies may be deduced from the fact that only a few weeks later a triple-engine traffic aeroplane with one thousand four hundred h.p. at its disposal dropped perpendicularly a good thousand feet when it encountered a downwind. The experience gained in soaring flight would enable soaring pilots to avoid such danger-spots.

THE FIRST SIXTY-MILE SOARING FLIGHT

FEW forms of sport have risen in popular favour so rapidly as soaring. This is not surprising, however, when we consider its attractions for the younger generation, its accessibility to all and sundry, and its infinite variety, and manifold grades of achievement, beginning with the first little "hop" and culminating in the great record-making feats which often bear a significance that lifts them far beyond the limits of mere sporting affairs. It is therefore not surprising that the press has always displayed a great interest in soaring, and after the ninth Rhön Meeting the *Grüne Post*, a well-known journal, offered a prize of £250 for the first pilot who should fly sixty miles in a motorless plane.

At first we pilots shook our heads thoughtfully at the mere idea of so long a flight and not a few impolite remarks were made about its promoters. But it was ever thus ; pilots grumble and then do what is asked of them.

Though the offer of this prize did not attract much public attention, all expert soaring flyers were immensely interested in it, and many trial flights were made. Ferdinand Schulz tried his luck over the dunes, Hirth and Laubenthal in their native mountains, and Kegel also made an attempt. From time to time we heard that somebody somewhere had started a flight for the new prize or crashed his machine while trying for it. Many waited with a patience born of despair for suitable weather for the record flight.

Schulz made one fine flight ; he remained in the air for four hours in the depth of winter but eventually had to give up on account of the difficulty of flying in driving snow. In the spring I made two flights from the Wasserkuppe in my new plane, the "Wien" (Vienna) which I had had built for me because I felt the necessity of acquiring a machine superior to any of the ones then in use, and in her trial

flights she showed that she could do all that I expected of her. Once that spring I rose so high under a cloud that the height could no longer be registered by my barometer, which was only capable of recording up to six thousand six hundred feet. Another time I gained valuable experience of flying in bad weather on a flight in heavy snow squalls.

The competition for this prize became serious when Johannes Nehring set out on a long-distance flight from a locality in the Odenwald, not far from Darmstadt, on April 3rd, 1929. He flew along the whole mountain range to Heidelberg, a stretch which could be accomplished by slope soaring, and then encountered the great gap which separates the Odenwald from the Black Forest. After a flight lasting one hour and forty minutes in which he covered a distance of forty-two and a quarter miles he was compelled to land. The bridging over of such a difficult gap as the one which brought Nehring's flight to a premature end can assuredly only be successfully achieved by the help of cloud soaring, but Nehring, the master on the hillsides, had overlooked this fact.

Undeterred, he tried his luck a second time, but could only manage an extra mile and a quarter. Although he did not succeed in winning the sixty-mile prize, he broke his own world record of the previous year for distance flights with the flight of forty-three and a half miles he made on April 25th.

By now it had become high time for me to get to work if I had any serious intentions of trying for this prize. I had selected for my attempt the terrain of the Teutoburger Wald, a district which, as far as flying was concerned, bore more similarity to the Rossitten dune country than to the mountains of the Rhön. The slopes of its hillsides were very low, the starting place lying only sixty-five feet above the surrounding level country. I had explored the district several times on a motor cycle, but its wide expanse rendered it impossible for me to make the close investigation I should have desired. However, time was pressing.

My first start resulted in a failure. While Nehring had tried on his last flight to make use of cloud upwind, I



28. THE AUTHOR'S RETURN FROM HIS FIRST CLOUD FLIGHT
(The Himmeldankberg flight in the Rhön 1928 Meeting)



29. A GROUP OF SOARING FLYERS AT THE RHÖN IN 1928. LEFT TO RIGHT :
Wolf Hirth, Ferdinand Schulz, Max Kegel, Edgar Dittmar, Fritz Stamer, Robert Kronfeld,

had resolved to make a trial of slope flying. But this proved insufficient ; after covering twenty-one miles, I was forced to land in a gap.

Ultimately I found that although this first sixty-mile flight was chiefly a slope-soaring affair, it could not have been accomplished without the aid of cloud upwind. On May 15th, 1929, a beautiful day, I started and flew along the hillsides, waiting for the help of a cloud only when slope upwind threatened to fail me entirely. At the same time I did no actual cloud soaring, but merely delayed my passage across the gaps until a cloud travelling in my direction floated above me and gave me the support of its upwind. Consequently I had often to wait a long time before I could pass from one upwind slope to another ; the whole flight was (like all slope soaring) difficult, detailed flying work, and I only barely contrived to cover the required distance.

It was this flight that revealed to me most clearly the drawbacks of slope soaring in comparison with cloud soaring. By the latter expression I do not mean merely a flight with cumuli, but also the utilization of atmospheric conditions which are quite independent of the influences of the ground and its formations. For a long time I had been wondering how it might be possible for me to progress to further achievement, as it was necessary deliberately to explore fresh fields of enterprise if the tenth Rhön meeting was to be a worthy successor of its predecessors.

Looking back, we can distinguish three phases of development. First came the technical development whereby the machines that could soar were evolved ; then followed the sporting period during which these machines were made to do all that it was possible for them to do ; finally there was the sporting-cum-scientific period in which trained thought had to direct the efforts of both sport and technique.

The extremely limited means at our disposal for flying sport in Germany made it impossible for us to hold a pupils' competition on the Wasserkuppe this year at the same time as the events for trained flyers and experts. Although the result of this was that comparatively few

planes were entered, there were certain exhilarating moments when we could watch more than ten planes tacking silently off the hillside at the same time. A duration prize had again been offered to the young flyers out of their apprenticeship in order to encourage them to cultivate staying power, and there was also a prize for the greatest elevation attained that would accustom them to cloud flying. On principle the conditions governing the events for the experts were left unaltered.

The standard of this year's meeting was clearly shown by the results of the trained flyers' events. Achievements that would formerly have constituted records were now quite commonplace. The young flyers had one and all mastered the technique of the cloud flying which I had demonstrated for the first time the year before, and consequently heights of from one thousand six hundred to two thousand feet were frequently reached. Even Dittmar's record height of 1928 was broken several times by newly-trained flyers. The average achievements were so high that it seemed entirely a matter of course that a pilot who had passed his "C" test during the competition should fly up to a height of over two thousand feet above the Wasserkuppe the very next day. Here, also, we perceived the value of soaring as schooling for flying in general. A young pilot named Bedau got into the clouds with his plane for a short time and was forced to "fly blind." He emerged with credit from an ordeal which is considered a most trying one even by pilots of engine-driven aeroplanes.

Meanwhile the planes "Darmstadt" and "M 1" were fighting for the trained flyers' duration prize. The "Darmstadt" was piloted by Neiningner, a colleague of Nehring, who was taking part in the "Tour of Europe" flight. Neiningner set up a new Rhön duration record with a flight of eight hours twenty-six minutes thirty seconds, while Herr Mayer of Aachen, an engineer, piloting a machine of his own design, was only four minutes behind him. Although the staying powers of the pilots were still unexhausted, this contest had to be broken off on account of a fog that arose with nightfall and rendered further flying dangerous.

FIRST SIXTY-MILE SOARING FLIGHT 101

With greater eagerness even than usual we looked forward to the experts' events. In spring a flight of sixty miles had been made over specially chosen country, and the question at issue now was whether it would be possible to repeat this performance from the mountains of the Rhön. The speculations of those pilots who placed the welfare of the movement above their personal ambitions were anxious ones. One thing was certain: the new record was hardly likely to be broken by slope soaring alone, at least as far as a start from the Wasserkuppe was concerned.

On the third day of the meeting a thunderstorm passed over the Wasserkuppe. I had already given much careful

KRONFELD'S RECORD FLIGHT BY THE HELP OF THUNDERSTORM SOARING

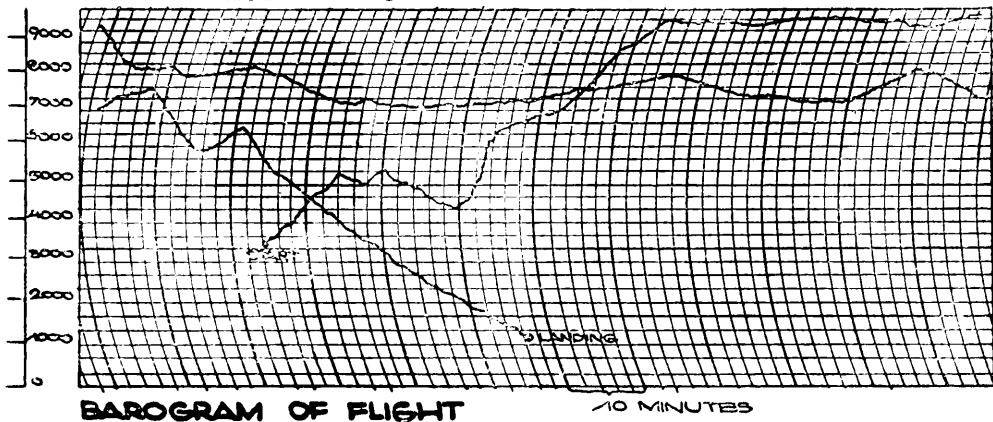

thought to the chances of utilizing the energies of such a storm and as it did not seem wise to attempt to battle with the difficulties of such weather unaided in my light machine, I had equipped the "Wien" with a contrivance for carrying a parachute.

I started at the exact moment when the storm burst over the summit. According to the plan I had already worked out and discussed with Professor Georgii, I set myself to keep my machine continually before the front. At first I was by no means certain whether this would prove possible as the wind was so violent that the steering power and flying speed of my plane hardly seemed capable of enabling me to remain in advance of the storm roller which was driving over the land. For a time I flew quite close to the cloud wall and struggled with violent gusts,

but during this early stage of the flight it became clear to me that I was entirely independent from any influences created by the formation of the ground. The plane, with which I had not made a single tack on the slope, continued to climb and at last, after a hard fight, I rose above the actual thunderstorm roller and could observe from above the projections of the front and the direction in which it was travelling across the land. After careful consideration I followed the course which suggested itself to me as best. The difference between my flight and Kegel's in 1926 lay in my systematic use of meteorological information. For a time I maintained a position immediately before and above the storm where upwind was to be expected, but later I tried to push out before its majestic front. I succeeded in doing so and discovered that even two or three miles in advance of the storm there was still enough upwind to keep me aloft. So I flew on at a height varying from six to ten thousand feet above all the influences of the earth and travelled far across the plain. I was only forced to land by the coming of night.

Thus, on July 20th, 1929, I established a double world record by making deliberate use of a meteorological phenomenon. My distance from start to landing place was eighty-five and a half miles, and I attained a maximum elevation of seven thousand five hundred and twenty-five feet.

My trusty "Wien" had suffered some slight damage during this thunderstorm flight, and the next few days were taken up by repairs. Meanwhile Hirth performed a masterly exploit by accomplishing a goal flight to the Schweinsberg and back. He set off from the mountain which was his starting place at a height of one thousand three hundred and twenty feet, and as the Schweinsberg itself offered no favourable upwinds he remained above a neighbouring hillside for a considerable time in order to increase his elevation. During this time he also made use of the upwind under a passing cloud, and the height he thus gained enabled him to fly to the goal. But the return journey proved more difficult than had generally been anticipated, so that Hirth was forced to reach the Wasserkuppe



30. THE "RUÖNGEIST" (SPIRIT OF THE RUÖN) BEING PREPARED FOR A FLIGHT WHEN THE TEMPERATURE STOOD AT 20 DEGREES (CELSIUS)



31. KRONFELD IN THE "WIEN"

by soaring along slopes far below it and then working himself up, thus reminding us of Nehring's magnificent technique. He landed three hundred and forty-five yards from the starting place after a flight to a goal nearly seven miles away.

This same pilot gained the prize for regional exploration by two flights, one over a course of seventeen miles, and the other over one of twenty-four and a half miles.

Ten days after my two world records the weather conditions of the area we intended to use for our flights were excellent. Mighty cumuli drifted over the summit, and everything that could fly was in the air. That day witnessed a whole series of fine flights, among them a cloud flight by a young pilot named Groenhoff, who flew with a passenger. He reached a height of four thousand one hundred and twenty-eight feet, from which elevation he glided twenty miles—a double record for a two-seater. I started about the same time as the others, worked my way up under a mighty cumulus and flew into it with the aid of the strong upwind. My plane, which naturally could no longer be seen from the ground, climbed and climbed. Flying within the cloud was not easy; traffic pilots who must sometimes "fly blind" for long periods take special instruments with them, for, as is well known, nothing whatever can be seen inside the cloud and even the most necessary points of contact are lacking. Without an artificial horizon many pilots lose control of their machines. Greatly to my sorrow, my speed indicator struck work in consequence of the choking moisture, and for more than half an hour I flew in the clouds by instinctive airsense alone, climbing continuously. At length I emerged at a height of one thousand five hundred and fifty feet from the same cumulus which I had entered at four thousand six hundred and twenty feet, thus accomplishing the first flight with a soaring plane in which such a cloud had been climbed through and the plane enabled to soar above the cloud ocean. I flew among the cloud peaks for an hour.

Meanwhile the last machine had landed on the Wasserkuppe and as nobody expected a great record in that weather, the good folk began to be uneasy about my non-

appearance. But I flew steadily on. First I crossed a plain fifty miles wide to the next hillside ; then I worked my way over the Frankenwald and the Fichtelgebirge for four hours by slope flying, in which the experience I had gained in the course of my flight in the Teutoburger Wald, when I had so often had to do such detailed flying, stood me in good stead. I landed at last in rain and wind and a foggy twilight after a flight of nearly ninety miles. My greatest height above the starting point was eight thousand five hundred and forty-six feet, so that I broke my own

KRONFELD'S RECORD FLIGHT BY THE HELP OF CLOUD SOARING

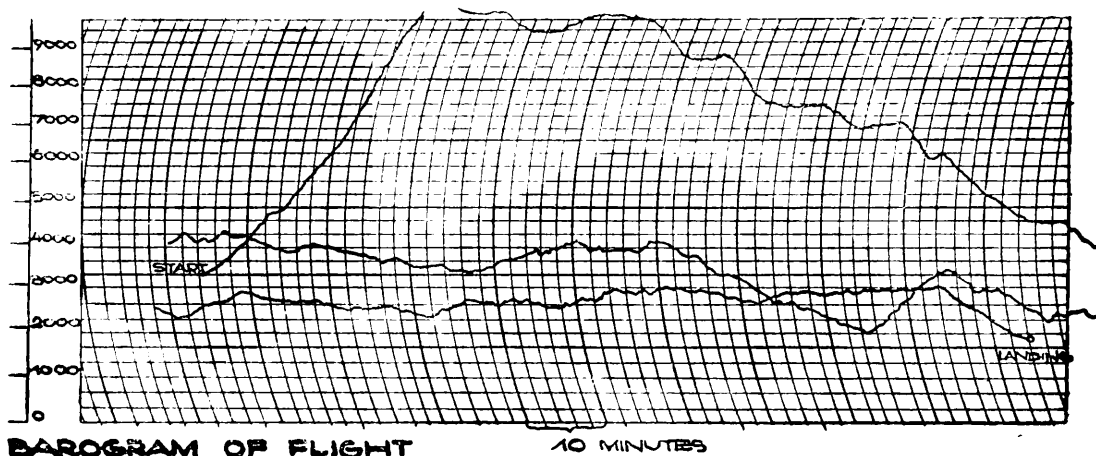

two world records in weather in which such long flights had hitherto been deemed impossible. But the records were not the most valuable results of this flight, for, as on the previous occasion, I was able to indicate the lines along which soaring must be developed if it was to produce the greatest results. Consequently the highest trophy of that year's competition, the Hindenburg cup, was awarded to me in recognition of the flying and scientific knowledge which my flight had acquired.

And so the tenth, the jubilee, competition, ended with a height record three times as great as that of the year before and a distance record twice as great.

Ten years of competition had passed by. Up on the Rhön, where formerly a few idealists whom most people ridiculed had pursued a new and uncertain idea, there is now a home for serious sporting and scientific work. Great

32. KRONFELD'S RECORD FLIGHT BY THE HELP OF CLOUD SOARING

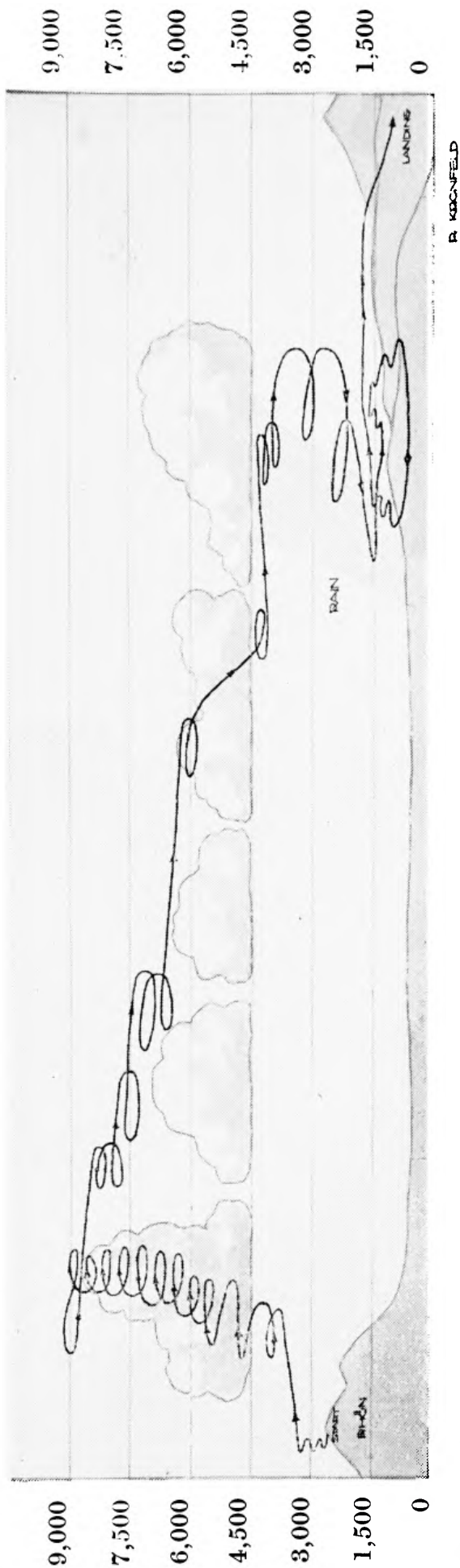



33. THE LIGHT WIND SOARER IN WHICH LIEUTENANT DINORT ACCOMPLISHED HIS FAMOUS DURATION FLIGHT



34. CUMULUS SEEN FROM ABOVE

Facing page 105

aeroplane hangars have been put up as well as accommodation for many hundreds of people. Pupils come from all the ends of the earth to imbibe the knowledge and experience which we have gained by long and strenuous work. When once a year the best pilots meet in emulation on the Rhön, the green hillsides are black with human beings. They come in thousands to marvel at motorless flying, to see and to learn. All languages may be heard there ; people from all lands are encountered.

The machines, which are finer and more skilfully built than any other flying machines, the successes and experiences which are reflected in the records achieved, and countless details connected with flying in general and with wind and weather lore will unite to proclaim the stupendous fact :

“ Ten years of soaring competition lie behind us, ten years of sacrifice, struggle and success.”

SOARING PILOTS REPORT

AS the great success of soaring flight on the Rhön during these ten years was achieved by the co-operation of all concerned, it is only just to allow those who put their best efforts into our work to tell their own tales.

NEHRING TELLS THE TALE

I

Alas for our poor "Margarete"! Why was I destined to be her murderer?

It was one of those lovely days which are so rare on the Wasserkuppe—blue sky, beautiful, white, heaped clouds and withal a steady, warm south-easterly breeze—just the weather for a roving flight! At that time we had only our good old "Margarete" on the Kuppe, as the "Darmstadt" was still at home in the workshop, where it had to be nailed and glued and painted. But we did not need it; in this wonderful breeze "Margarete" was the best possible flyer.

So, one after the other, several passengers went up with me, and they were all enthusiastic about the delights of soaring and the splendid bird's eye view of the Rhön. In the meantime a special prize had been announced for the longest flight of the day. "Margarete" must win it, I decided, and, in order to take advantage of every chance, I went up alone this time. The decrease of weight enabled me to gain a greater height, but when I was over the Pelznerhang I turned to fly back to the Kuppe, towards which I now rushed madly with a cross-wind behind me. For a moment my attention wandered. I turned a trifle too late above the Flying School and was carried by the wind beyond the "Baude" (the Inn on the top of the Wasserkuppe). It was lucky for me that I was still about one hundred

and thirty feet high. "If only I am not forced down on to the 'Baude' or into the downdraught behind the Kuppe," I thought, "or, worst of all, among the people who are standing about in such dense groups." I pressed the bird as strongly as possible in an effort to push forward against the wind, which is always strongest close above the hill tops. I was just flying over the "Baude" at a height of about fifty feet, and hoping to reach salvation in the upwind in about another thirty.

Suddenly the stick jerked in my hand! "The aileron!" I cried.

The steering cable had not been strong enough to stand the immense pressure; it had snapped. "Margarete" went over with a jolt on to her right wing. I tried all I knew to get her level again with my remaining controls, but in vain! We were too low down to do any good. Beneath me were two flying machines at the starting place and a black, moving throng of people. Heaven be thanked, the strong wind was driving me past them; I descended but Margarete's right wing hit the ground with a crack, and a groan and the next moment her body crashed. I found myself entangled in a mass of spars, ribs and fabric, and the cracking continued. I tried to turn round; then I saw Chief-Instructor Stamer come running towards me with horrorstruck eyes. I looked up, and saw that the other wing, which was standing upright, was about to collapse. Seeing the danger, Stamer caught the wing and managed to ease it off a bit; I turned my head aside, and it crashed into the grass close beside me, groaning in every joint.

Good old bird! How we tended and cherished you. At every competition something new was added to you. In 1923 you wore a yellow dress and had a very, very shaky elevator and ailerons. That was soon altered. In 1924 we gave you beautiful white wings, and your white dress suited you on the dazzling dune sand of 1925. We always thought of something new for you when we took you to a Meeting. And how the Russians admired you who came to the Rhön in 1925, and they also adored you in the Crimea, when you sailed with Hesselbach through the air for flights of three and six hours. In 1926, on the day

that Kegel brought off his thunderstorm flight, you demonstrated in storm, rain, and hail squalls that you still remained young in spite of your three years. That time you were rewarded with a prize for special merit. In Rossitten in 1927—we had started you with a beautiful new gown of varnish—it was your ambition to break Schulz's endurance record. Oh, that wind! After six hours it stole the upward current that bore you aloft. You fought like a lioness that time for every foot of height, long after all the other soarers had given up. Brother Wind grudged you the triumph.

You attended your eighth Meeting. Where were all the other champions who flew forth with you in 1923? You outlived them all, and you could have wished for no better death. In the midst of the battle for a great prize—though you were ever ready, were the prize great or small—it found you. How we shall all miss you—most of all the pupils! You helped all our pilots in their Soaring Flight Test. Yet, faithful as you have been to us through four long years of life, you will not leave us without others to take your place.

II

I had just landed the "Darmstadt" near the Flying School in the middle of the Wasserkuppe plateau. Nothing was impossible with this bird; it steered as easily as a motor-plane.

I slipped down over a wing that nearly touched the ground and then flattened the machine out at the last moment—the best way to land at a goal. And then the pessimists began: "You won't stop till you have killed the 'Darmstadt,' too!"

So I had landed beside the school behind the hut. We rolled her up to the starting place, which to-day was close to the hut. The wind was south-west by south, velocity six to seven feet per second. At half-past three I said: "Come, let's have our coffee; there's nothing doing to-day in this light breeze." I had no inclination to fly. In the flight just completed I had barely attained a height of

five hundred feet above my starting point, which seemed to me too little for a distance flight. "But a special prize has been offered to-day; to win it you need only fly about a mile less than yesterday's best. You must start!" said a friend. "Twelve miles! Well, have your own way!" I replied.

The barograph was hung in the machine by the officials. "Everything ready?" I asked. Behind me was the tail crew, the foremost of whom held fast to the tail skid; in front were the launching crew, to right and to left five men formed a wedge on the thick double rubber rope, the ring of which hung on the starting hook at the bow.

"Ready?" "Pull out." The launching rope is drawn out; the launching crew, bending to their task stretch it to its utmost tension. "Run!" "Let go!" The holder lets go!

Oh, what a thrilling moment it is when the machine shoots up into the air! Not only for the onlookers, no, for me, too, this is the finest moment of the flight. A force, a power resides in the taut rubber cable which can only be realized by the man who has been propelled into the air in this fashion. A torpedo steers itself when released from its tube; the soaring machine is an aerial torpedo, even though its steering mechanism is guided by a human hand.

The upwind was no better than before; the projecting ridge, which is the northern continuation of the Flyers' Memorial rock, was the only place where I found a slight current, but, tacking over this slope, I crawled up to a height of four hundred and sixty feet. The wind blew in the best possible direction for a long-distance flight, but at this elevation how was I to cross the great valley in which lay Brand, Wickers and Reulbach? First I flew along the slopes east of the Ulster, for I felt sure that this was the way to bring off a long flight I had worked out on the map for similar winds a year ago. Turning my back to the wind, I flew down to the Ulster, but what a horrid downdraught caught me below the Kuppe! Alas for my excellent, hard-won altitude! Foot by foot I was pushed down.

But at last the gliding angle decreased northward of Brand and Wickers. I found there was an upward breeze playing round two small hilltops. So now to try for the Buchschirmberg! One thousand seven hundred feet, says the altimeter, one thousand six hundred. And then, hurrah, the bird is rising. I turn before the slope and soar above it; I have managed the leap across which seemed impossible.

If I can carry on now without a mistake, I shall pull off the big flight. But what about the wind? I positively must not fly round the wrong side of any summit, for if so I shall be on the downwind side, lose height and be compelled to make a forced landing.

No chimney smoke was to be seen far and wide, but the shadows thrown by the many cloud-hills were the best of weather-cocks that day. The smoke trails from chimneys may be deceptive as they are often too strongly affected by purely local conditions. I had now to make for the Auersberg; in many arguments I had heard many opinions about this summit, but this time I found that my own theories were the right ones, for here I rose again almost to my starting height! Once it was nearly all up with me. The drift of the cloud shadows across the slanting slope (some optical illusion, perhaps) must have led me astray; I got into a downward current, and in less than fifteen seconds it dragged me down nearly three hundred feet. It flung the machine violently about, and I was more than thankful to get back to the upwind side, having learnt the lesson that I must be still more careful. Often I gained height for further gliding by tacking before broad single slopes.

As I flew over the Dietrichsberg, I saw a quarry six or seven hundred feet below me, where workmen were breaking up stones and carrying them away in wheelbarrows. I bawled a loud "Hallo!" down to them. They turned round several times without being able to make out where the sound came from; then I shouted again. At last one of them discovered me and pointed me out to the others, all of whom stood staring up, speechless. How well I understood! To this day I who have seen so many

flying machines can watch them for hours at a time. The serenity and majesty with which these aircraft circle upwards in the wind like birds of prey never fails to move me and only when the pilot calls down to me do I cease my awe-inspired vigil to send a jubilant greeting up to him on high.

I had flown over Vacha, which lies where the Ulster and the Werra meet. Hardly anyone noticed me, though there too I shouted down my "Hallo!" The one thousand three hundred feet of space seemed to swallow up my voice. The rest of my trip was an easy gliding flight. Before I reached Vacha I had done all my real soaring; I had utilized the upwinds in the new regions to carry me along, but here the slopes lay almost parallel to the wind, and up-currents were not to be expected. From a distance of several kilometres I saw a great meadow beyond Berka, which seemed a good place for me to land. I brushed over the houses of Berka, with the wind at my back, at a height of hardly more than from seventy to a hundred feet; I could almost hear the grass rustling. I found such a long meadow that I ventured to land with the wind behind me; the starting hook beheaded the clover and bombarded my face with the blossoms. I screwed up my eyes and rejoiced in the merry game which was new to me.

And now the first curious folk came hurrying along on bicycles from Herda, which is only a few hundred yards away. I took possession of one of the cycles and rode off to send a message from the village to the Wasserkuppe. When I had dismantled my machine and stabled it in a farm, the mayor of the place, beaming with joy, presented me with a bouquet. But my joy was even greater when one of my comrades arrived on a motor cycle and shook hands with me!

I had flown thirty-two miles and so fulfilled the first of the conditions laid down for the offered prize.

LIEUTENANT DINORT REPORTS

It is fine to gain a world record; it is splendid when this means that you spread the honour and fame of your homeland all over the world, while at the same time you

are doing pioneer work. I set out upon my endurance flight of fourteen hours and forty-three minutes inspired by the sublimity of this idea and encouraged by the tradition of Ferdinand Schulz who was so closely connected with our Rossitten.

On the afternoon of October 19th, 1929, we drew the machine to the starting place on Predin Hill, near Rossitten. The breeze blew gently over the Kurische Haff from the east with a speed of only eighteen feet per second. The afternoon sun shone enticingly from a blue sky flecked with fleecy clouds. The Flying School pupils were diligently practising gliding under their experienced instructors, Arndt and Lorenz. The members of the launching crew grouped themselves eagerly around me, as with my pockets stuffed full of chocolate and sandwiches and with a ginger beer bottle on each side for balance I was heaved up into my airy seat by willing comrades. "Barograph all right? Ready? Pull out! Run! Let go!" The launching rope fell at 3.20 p.m. and the machine rose in an upward current that gave me a good height to start off with.

After a short test of the flying area I settled upon a "pendulum" flight of about three quarters of a mile long. I tried to fix in my mind exactly the contours of the country at the turning places in order to be as well prepared as possible for the forthcoming night flight. The first few hours passed unusually quickly, as thoughts concerning my plans for the night helped to pass the time. Meanwhile the sun was approaching the horizon over the Baltic Sea, and gazing at a wonderful, red, glowing evening sky, I ate my supper comfortably, floating along almost in silence and accompanied by ever-changing flocks of birds of passage. They flew trustingly close beside me and greeted me with their cries. Then, almost suddenly, came the mysterious darkness, with a cloudy sky and fresher breeze. The expected moon, which was to have lighted my course, did not appear, so now it became urgent for me to quickly obtain some artificial light from below. Captain Röhre, the Director of the Flying School at Rossitten, started to make the necessary arrangements, but they took time. In my airy seat I began to feel distinctly ill at ease; below

me in the dark lay a ghostly greyish-white level stretch which I knew to be the dunes, while a darker area beyond them I recognized the water of the Kurische Haff. It was impossible to calculate height ; below me I saw vague human figures in the darkness, and now the time began to drag. Every moment I expected to find myself in collision with a sandhill ; the breeze freshened and I gradually lost all feeling for the position of my machine. The open seat gave me no help ; I had to do my best by noting the position of the curved border of the wings, which were edged with bars of hickory wood that showed up fairly well against the sky. From time to time Captain Röhre enabled me to gain some idea of my height by striking matches, and at last the desired ground lights made their appearance in the shape of petroleum stable lanterns. But they were hardly in action a moment before they were blown out by the ever-freshening breeze, which was now blowing at a velocity of sixty feet a second. They were lit again and again till all the available matches were used up, but only one lantern remained alight. Many were buried beneath the drifting sand that the wind drove over the dunes. Magnesium flares were now lit, but their light was too glaring ; they dazzled me so much that I could hardly maintain my position in the air. At last there came fresh and reliable help in the form of electric pocket torches which had been procured from the village of Rossitten. Then new boxes of matches and supplies of petroleum arrived, so that there was enough material to keep the ground illuminated all through the night.

The valiant members of my aerial police force grew hourly more accustomed to their work ; I, too, was getting more used to this night flying. Towards midnight the full moon looked out now and then through the clouds which covered the sky, and in its pallid light the sandhills assumed grotesque shapes. After the moon had finally withdrawn behind the cloud curtains, the night seemed as if it would never end. From below the watchers tried to call up the time to me, but their voices were swallowed by the wind so that I could not understand a word.

How slowly the time passed ! And then there came yet

another trial of my endurance—rain! It was an unspeakable relief when at last it ceased and the grey dawn announced a new day. Muffled shapes—the watchful sentries on the dunes—became visible. And now the time passed more quickly and flying grew easier. I breakfasted.

At last I had flown as long as the holder of the former world record. Half an hour later my control lever broke. The good glider which had endured so well with me through the stormy night landed me at three minutes past six on October 20th, 1929.

I thanked God, who had so graciously helped me in my need.

OUR FIRST SOARING FLIGHT IN AMERICA

By P. LAUBENTHAL

Cape Cod! The name conjures up in my mind our wonderful experiences in a beautiful warm New England summer on the Atlantic coast of America. As I pen these words, only three months, but four thousand miles separate us from the golden slopes of the sandhills of that peninsula. It so chanced that its position made it the starting point of American history, and it afforded us flyers the best opportunity we had ever experienced in the history of Soaring Flight.

“Where the pilgrims found maize the German gliders await insurance,” wrote our friend D. Rochford, a true flying enthusiast, in his Boston paper soon after we had settled down on Cape Cod.

His words sounded an impatient note and yet they were comprehensible to the expectant American readers who read with growing interest the reports of our arrival on the New England coast and were eager to hear of a record flight in a motorless aeroplane.

The discovery of Cape Cod for our motorless flying was due to chance and the kind endeavours of a Boston friend, who was a member of the North German Lloyd.

Here on this coast lay the first settlements of the Pilgrim Fathers, those stern Puritans who gained a footing there

at the beginning of the seventeenth century and became the founders of the United States of America in general and the State of Massachusetts in particular.

Their descendants have put up memorials to the historical past, and on our Corn Hill, a steeply sloping dune beside the bay, the crest of which ran south by north-north-west, we read on a bronze plate (the granite pedestal of which was buried in the sand) that sixteen Pilgrim Fathers landed there on November 16th, 1620, to obtain from the Indian inhabitants corn for their own fields. In the little neighbouring town of Provincetown, where fishermen ply their trade and health-seekers and artists find refreshment and inspiration, there is a memorial tablet on the Town Hall, perpetuating the first Constitution of Massachusetts.

But I do not propose to write history, except that of our flights on Cape Cod, and will therefore proceed to give the reader some idea of the character of the landscape.

Cape Cod is a peninsula stretching out like a bent finger into the sea north-east of New York and south-east of Boston. Its outer extremity, on which stands Provincetown, points almost directly to Boston, whence it can be reached by steamer in four hours. The country reminded us of the Kurische Nehrung, but without its gloom. Soft, billowy hills are covered with dry, grey-green grass and sapless, unkempt, straggling green whortleberry bushes. In the fruitful marshy country at their feet, we see everywhere the white-painted wooden cottages of the summer visitors.

Our flying area lay almost at the north-east point of the peninsula, eleven miles from Provincetown. The steep slopes of these dunes extend westward, and from their summits the coast of the opposite mainland is plainly visible in clear weather.

We took two of the little summer cottages and made ourselves as comfortable in them as possible.

Here we wanted to fly, but starting conditions were unfavourable. At first we were in no particular hurry, for we had still to conclude our insurance arrangements. Moreover the wind had not yet been able to make up its mind to blow favourably for us ; we had therefore leisure to

explore the coast and investigate its possibilities. We found that the steep coast extending outwards in a huge convex bulge towards the ocean seemed more likely to be practicable for us than the inland slopes. To begin with, starting conditions were far better there, but we realized that it must depend entirely upon the prevailing winds whether we undertook our first flights from Corn Hill or the neighbourhood of Highland Lights, a signalling station on the ocean side.

We had thought that we could make our preparations in all secrecy, but here we were greatly mistaken. All events in America are exposed to a much greater publicity than is the case in Europe, and our manager, Frank Blunk, had already drawn attention in a newspaper to the arrival of three German soarers on Cape Cod. Unfortunately for us, he thus saddled us with the pack of reporters and film photographers who are always at the service of an omnipotent press on such occasions. In the days before our first flight we were regularly besieged ; as a matter of course, this army soon made itself as much at home in our two cottages as we were ourselves in a manner that was as amazing as it was naïve. But among these pressmen there were some splendid fellows who showed the most complete understanding of our difficult position and did much service to us by their reports.

For us the period of waiting was a great trial. We wanted to fly ; everyone wanted to see us flying and urged us to action with all the emphasis of a press that meant so much to us as far as popular success was concerned. We received weather reports and carried on our investigations day by day. The blacksmith of Provincetown made us a starting apparatus and rings for the launching cable, while with mingled hopes and fears we awaited the coming of a fair wind, of which we could not make use until we received news from New York.

On July 17th we drew the " Darmstadt " (which had previously been exhibited at the Detroit Air Olympics) out of its shed and put it together. One after the other we were compelled to climb in and pose ; then an entirely unknown lady got in and hardly was her picture taken than

another belated photographer came running with his box of tricks and wanted everyone to pose again.

On the following days the wind changed to the east and wafted heavy, low clouds against the slopes of Highland Lights. As this wind promised to hold we motored on July 20th, with the "Darmstadt" in tow, to the ocean slope where we proposed to attempt a start. The rumour of our coming had spread rapidly and we steered to the little parking place into which the coast road broadened out amid hearty cheers from a crowd of spectators. The wind was favourable but the clouds hung deep and were drifting in black masses over the ocean. Before we could unhitch the trailer, rain and mist had rolled up and we hastened to house our bird in the shelter of a neighbouring barn.

A day later we refused to let the weather deter us from putting the "Darmstadt" together. It was a mistake on our part, for the wind was not blowing strongly enough to make flight possible, and expectations had been excited to the highest degree. Reporters, film-shooters and summer visitors surrounded us, questioning, taking notes, begging for autographs. They challenged us, alleging that we were always putting them off, and demanded that we should at least show them something. What was the use of talking and explaining? To prevent public interest cooling and spare ourselves the otherwise inevitable sarcasm of the press, a flight of sorts had to be made. So we decided upon a "good-will" start which should end in a glide down to the whitish-yellow sea beach.

There was very little room, and the starting-run for the launching crew was all too short, but something had to be risked, even though we were working with untrained volunteers. It was not easy to select our helpers, for everyone wanted to take part. After giving our crew preparatory exercises with the rope, Hesselbach climbed in and began to give the starting orders, while Captain Röhre directed the tail crew.

A short whistle. As the tension began to make itself felt our bird slipped forward until brought up sharp by the tail crew. At the second whistle things began to get a move on and the crew ran forward in the direction of the slope.

Then a third whistle, which was for the tail crew. I was the foremost one on the rope, at the right, and shouted : "Run—run!" The tension slackened ; as I ran, I looked round. The machine slipped, glided, seemed to free itself and slowly approached the slope that fell away immediately ahead of me. The start had been a poor one, and it was made worse by the dead eddy directly behind the edge of the incline.

What was to be our luck ? After a moment of suspense the skid slid again, the left wing turned towards the ground, and, swaying slightly, the bird came to a standstill close to the edge. We all breathed more freely, but the silence of the spectators betrayed the anxious expectation with which they had followed the last movements of the machine. Although they acknowledged our personal courage, we could read on their faces their doubt as to whether motorless flying were humanly possible. We knew that we could not make another start here.

Wonderful golf links lay a few hundred yards to the south of the station, with their smooth green lawns extending right up to the slope. We all know how precious and holy his golf links are to the American, but nevertheless, through the influence of a lady friend, we obtained permission to use the links on condition that all spectators should be kept outside their boundaries.

There four further starts were made in a faint easterly breeze. They were hardly to be termed starts in the strict sense of the word as it was impossible to hold back the plane until the rope reached its full tension. The spectators smiled more broadly, and the press representatives hardly troubled to conceal their doubts. Further attempts had to be abandoned as the wind dropped completely.

But on Thursday, July 26th, a strong north-east wind blew from a cloudless sky. A brief inspection of the ocean side raised my hopes ; a wonderful steady breeze was blowing towards me across the open plateau, and the distance out at which "white horses" topped the waves proved its constancy. This was just the weather for us ; within an hour we had the machine ready to start. The wind blew from the north-east at a velocity of about twenty-four

feet per second. Some golfers, clad in the white flannels of summer, willingly helped us to start. The same commands as before. Slowly at first, but gradually gathering speed our bird glided on her wide spread pinions ; she floated gently to the edge and then, caught up by a rising breeze, she flew off in a gentle left-hand turn, following the lines of the dunes. Spectators, pressmen and photographers at first stood dumb, and their silence lasted until the plane began to rise. Then an immense and uncontrolled enthusiasm broke loose ; cheers rose up to the bird which was now soaring more than three hundred feet above our heads. Everybody rushed to us, congratulated us, shook hands with us. "To see a thing like that is worth waiting for a whole month," said a cinema man, grasping our hands excitedly ; then he dashed back to his camera.

The "Darmstadt" was still flying calmly and steadily above us, but it seemed that Hesselbach intended to land, for he flew inland in wide curves, turned back and let the machine float close down over us. Then he glided over the edge of the slope and swung himself aloft once more, a manoeuvre which evoked further enthusiasm. After a few more flights backwards and forwards, accompanied by steep turns, our bird took an inland course. Hesselbach was seeking to land.

As he descended, the whole surface of the plane was visible for a moment ; then it disappeared behind a rise in the ground but immediately reappeared, flying low down and directly towards us. The machine settled down gently, slipped along a little, and subsided slowly on to its left wing. The flight had lasted an hour all but two minutes. All the spectators rushed up cheering, shouting, whistling, and giving vent to their delight in every possible way.

The bird lay motionless ; enough had been done for one day. And while we were still busy dismantling the machine the news of this first soaring flight in the New World was being transmitted over all the cables of the New World.

The reception which this noble sport met with in America can perhaps best be realized from the title of an American leading article :—

"SOARING GERMANY'S GIFT TO SPORTING AMERICA."

A RECORD FLIGHT ABOVE THE CLOUDS AND OVER THE SEA

By WOLFRAM HIRTH

Many have been my experiences during the six years of my career as a glider and soarer—crashes, storm-flights, altitude flights, etc., but the first time I actually flew in the clouds and in fog was in France, at the Vauville Flying Meeting.

This Meeting had not been favoured with much wind, but, as it was drawing to its close, on the last day but one a fine west wind with a velocity of twenty-one feet per second sprang up. That day I resolved to attempt to break Nehring's distance record of sixteen and a half miles.

But the weather was doubtful ; over the " aerodrome " hung a bank of cloud, at a height of about two hundred and sixty feet, which began a mile away on the coast and remained stationary all day. The upward current was so strengthened by the wind velocity that I reached the clouds in a few seconds and plunged into thick fog. Everything was white around me. I told myself that this cloud layer could not be so very thick, because far away out at sea the sun was shining in places. I resolved to try to get through it.

My conjecture was right ; in a little while the air grew clearer, and soon my great bird hovered a thousand feet above the starting place, which naturally I could not see.

It was so wonderfully beautiful up there that I flew for three quarters of an hour between two layers of cloud, as far above me, some seven thousand feet high, there was another cloud ceiling, which only let the sun through here and there. When I read on my altimeter a height of one thousand one hundred and fifty-five feet, i.e., when I was flying some one thousand six hundred feet above sea-level, I set out on a distance flight.

In order to get round the steep Cap de Flamanville (which my comrades had not succeeded in doing during the previous days) I flew about two miles out to sea. It was a risky proceeding in a motorless plane, but with the aid of the excellent altimeter that indicated my reserve height, I succeeded. The flight went so quietly that I could let

my thoughts go woolgathering. On a road below me I saw a boy being whipped by his mother ; I shouted down "Hallo!" whereupon the stalwart dame let go and the lad ran off. I suppose he took me for his guardian angel. On the other hand I was certainly mistaken for the devil by an old woman who was gathering driftwood on a lonely part of the beach, for she sat down in sheer amazement when she suddenly saw me flying along silently and mysteriously sixty-six feet above the sandhills.

After a flight of seventeen miles I reached the last and most dangerous mile of my motorless trip—the stage where I had to round the Cap de Catêret. I began this difficult undertaking at a height somewhere between thirty and fifty feet, but dropped until I was only fifteen feet above the ground. On my left, above my wings, were overhanging rocks ; on my right, the immeasurable depths of the dark sea. The spray was flung right up to me, and I felt anything but comfortable. Then came the outermost point of the cape, and with it salvation. Round it lay the long, lively beach of a bathing resort, crowded with fashionable visitors, children, hotels, deck chairs—in a word, I had reached Catêret.

I landed smoothly and was surrounded by hundreds of spectators who inundated me with questions, such as : "When will you fly away again?" "Have you come from America?" "Where are your engine and propellor?" Then, too, came a custom house official who wanted me to pay duty on my machine and show him my passport. Then I was invited to dinner and fêted.

But the best of all was my own pleasure in the wonderful flight, the new record and the winning of the competition.

ABOVE THE RHÖN AS A PASSENGER IN A MOTORLESS PLANE

By DR. ALFRED DETIG

"Pull out! . . . Run! . . . Let go!"

The lean young man before me utters these words slowly, loudly, with cold matter of factness. But this time I know that they are of vital importance to

myself ; there is no turning back, for I have definitely embarked upon my first soaring flight ! Our white bird has been lying in line with many others upon the rounded, grassy mountain height ; a few moments ago two cousins wedged me in with much difficulty behind the pilot in the incredibly narrow cockpit of the soarer, which now sheathes my long body and legs as closely as the cocoon enfolds the chrysalis. We start with a velocity of fourteen " m.p.," i.e. " man power." At the first word of command two teams of men put themselves in motion and pull out the two pairs of rubber ropes to the other ends of which we are attached ! But meanwhile our plane is held fast by the tail by four sturdy fellows who dig their heels into the grassy soil. And now at the second word of command the fourteen begin to run for all they are worth and for all the rubber is worth, and the one who pulls most frantically is my cousin ! And then, then . . .

The mighty word " Let go ! " for which I have been waiting with strung-up nerves, rings like a deafening gong in my ears and releases me at one fell swoop from all my tension. What has happened ? Has the narrow wooden cockpit grasped me convulsively, like a clenched fist, and flung me up one hundred or one hundred and fifty feet ? I am conscious of such strong pressure that I instantly lose all powers of sight and hearing and try to huddle myself up in my narrow box. But this absolute passivity during such an unprecedented experience seems to me intolerable, and gradually my brain begins to work. We are still hanging on to the rubber ropes, and I cast a rapid glance over the plane's wooden side, which gives me a feeling of safety. I watch the rubber ropes detach themselves from the hook and whistle as they whirl down earthwards. Far below us our sudden release has sent several youths of the launching crew staggering down the slope, and he who staggers most and farthest is again my cousin ! Our soarer now makes a gentle bow of the kind that I have often noticed from below ; it is her sign of gratitude because we have now freed ourselves from all earthly things and are floating out over the deep valley, away from the crown of the mountain top. With our plane we form a

living arrow that has been shot from a taut bow out and up into endless space! It is an unforgettable moment for me—of incomparable significance for those able to appreciate it. For one brief instant our aircraft seems to be a rocket that shoots up from the earth by its own force—a harbinger of forthcoming developments! And from now onward we must depend entirely upon ourselves, for already, one moment after the start, we see one thousand three hundred feet beneath us in the valley, a forest and jagged rocks . . . not a very attractive prospect.

At first we sail straight on in the direction of the Eube, but my trusty pilot turns suddenly against the wind above the Gersfeld Valley, and just as suddenly my heart is in my boots. I feel quite distinctly the thin wires rubbing against my coat; they run right and left along the sides to the elevator and the rudder at the end of the fuselage. I therefore exhale strongly so as to make myself as thin as possible and avoid hindering the steering. Am I not with my thirteen odd stone too stout a passenger?

Now we are canting over in a turn, and a shiver runs down my back to my knees and thence to the extremities of my long legs which I have twisted into an inextricable knot. Anyone who knows only the flight of engine-driven machines always feels that a soarer is side-slipping over the inner wing when it goes into a turn, even though he may have been previously warned, because he misses the mechanical forces that right the machine.

Now we have turned, and the wings with their fifty foot span, delicate as cobwebs, moan and groan under the strong head wind. For a brief moment I ask myself: "Will the 'birdlime' hold that connects the thinly varnished slips of wood?" I began to wish I had listened to the friends who warned me and pointed out the mad folly of expecting a machine weighing about two hundredweight, which weight is diffused over a considerable surface, to bear the additional three hundredweight which the two people seated in it must weigh. But I trust myself to my lucky star, to the efficiency of the constructors, and call upon Coué for help, repeating again and again, "It will stand it, it will stand it." But soon these anxieties and

fruitless thoughts vanish, and then comes the great miracle.

We are rising steadily as we sail along parallel with the celebrated Pelzner slope, sometimes slowly and steeply, as in a lift, sometimes more quickly and with shorter steps, as if on an invisible staircase in space. I see no force, I hear none, I only divine: and I revel in a boundless intoxication of the senses in this incredible fairy tale! And henceforth when the wires sing softly and the wings groan, they sound in my ears like the tender chords of a harp or, when we face a strong and rising head wind, as if someone were playing Scarlatti on a spinet! Now I can fully understand why men will starve themselves and work their fingers to the bone for months, so that they may save enough for a few weeks' soaring in the Rhön country. It is a return to romance from the days when 500 h.p. engines propel comfortable flying ships through the air like taxis.

And now we find ourselves in the best of good company. The unbelievable becomes the event, and we climb up till we join the masters of soaring flight who have been circling above us for hours in the remote silence. Earthbound, I had watched them longingly from the Wasserkuppe for the whole morning prior to my start. All the "experts" had declared it sheer madness for us to contemplate attaining such a height in our heavily laden craft.

Nearly all the high-grade one-seaters have to-day undertaken an attack upon the endurance record, but a favourable upward breeze and my pilot's fabulous skill have raised us up to the same height as the big guns of this year's "Rhönggeist" competition and kept us there.

To-day is a world record day of the first importance: Kronfeld of Vienna has been sailing in his "Spirit of the Rhön" over the Upper Rhön for four hours and a half, and before he comes down he is destined to prolong his flight to eight hours, and so break all previous records of duration flights from the Wasserkuppe. Also Nehring of Darmstadt, Kegel of Cassel, Wolf Hirth the Swabian, Schulz from West Prussia, and the dainty "Hessenland" are circling with ever-changing luck, over the summits of the Rhön mountains in competition with Kronfeld; they

want to wrest that duration record from him before the end of the Meeting, if it can be done. Unfortunately, Dittmar of Fulda has not brought his "Albert" here on account of a slight accident. Five days ago he attained the fantastic height of five thousand seven hundred feet in a motorless plane and thus upset all previous opinions on this point.

While our good soarer sails slowly against the wind, gaining foot after foot of height by expert handling, I find time to study my pilot more closely. He is Alex Schleicher, designer, builder and flyer in one, a second Espenlaub. Schleicher is the only native of the Rhön among the motorless flyers; his home is at Poppenhausen, a health resort perched high up at the foot of the Wasserkuppe in lovely surroundings, from which our machine takes its name. He learnt carpentering in his father's workshop; then, as a young man, he found employment in the Rhön-Rossitten Gesellschaft's small aircraft factory on the Wasserkuppe, where his idealism and fanatical, indomitable perseverance enabled him to overcome many difficulties and made him into the well-known manufacturer that he is acknowledged to be to-day. His specialities are the two-seaters that he puts together with his own hands in his own workshop, and he could not tell you how many nights' sleep he had sacrificed to the difficult work on these machines. It has indeed not been easy for him, as a self-made man in every respect, to attain his aims, often in the face of many unnecessary obstacles. The Rhön may well be proud of the son, whose achievements we all write to honour!

Of the hundred flying machines entered for the Meeting, only five are two-seaters, two of which have hardly been seen out. Of the remaining three, two were built by Schleicher. The celebrated Krause, of Berlin, gained all his prizes with a machine built by Schleicher, the man who crouches on the pilot's seat before me with the control lever in his hand and his feet on the rudder bar! His head and his hair look as if he had designed them himself; he has the head of a Titus—square at the top and falling down on either side like a pair of short wings. Two deep

furrows in his face taper down to a chin like the body of a glider. These are the traces left by his self-denial and tenacity of purpose! Everything about him proclaims the hard common-sense which joins with his innate modesty to prevent the inspiration slumbering in his heart from finding outward expression. In short, this carpenter of Poppenhausen is a character like the one so finely drawn by Max Eyth in his novel *The Tailor of Ulm*, the man born a hundred years before his time, from whose tragic fate Schleicher will certainly be spared. For the tailor of Ulm made for himself a pair of wings which were to be moved by his arms; thus equipped, he leaped from the steep bank of the Danube, and, falling, met his death.

Now Alex Schleicher makes a second steep turn, and we fly before the wind at a speed of from thirty to forty miles an hour, high above the mountain group of the Wasserkuppe. For the first time I realize the tremendous height to which we have risen. At the same height, but at irregular intervals successful soarers come flying towards us, and Schleicher flies in and out of their midst at top speed in masterly fashion. First we meet the Viennese Kronfeld, and henceforth I am lost in a mere fantastic dream. Silently, like a phantom ship in the night, he glides past close to us. He claps his hands at us because we have climbed so high and now I too am moved to break the holy silence with a loud "Bravo!" Then I ask him if he is not hungry after nearly five hours flying; he understands every word, and his face breaks into a smile while his teeth gleam like two rows of pearls in the sunshine as he lifts his hand to show me some slabs of chocolate and a sandwich—his provision for his record flight.

Alex told me that when the air was crowded—to-day, for example, two hundred flights have been made—it was necessary to be very careful when exchanging greetings with Kronfeld, because, hailing from Vienna, he had transferred his Austrian rules of the road to the air, so that he passed the other aircraft on the left instead of the right and always made his turns in unexpected directions.

In the meantime Nehring, nicknamed "Bubi," the everlasting boy, in his loudly checked knicker suit, is drawing

near to us. A few days ago he flew fully forty-five miles to Tiefurt, near Eisenach, but it is obvious that he does not find it easy to maintain his height to-day, and as we fought obstinately for height over the Pelzner slope, and succeeded in gaining it, he has to slip by below us. Nehring has a pretty wit, for when I cast a triumphant glance into his machine from above, he called loudly, "Fat always floats on top!" Truth to tell, the finely cut lines of his soarer are an embodiment of beauty. He seems to ride through the air between two razors which curve out at the sides and meet taperingly at each end.

Schulz from West Prussia is also out of luck to-day; he has been sailing in the air for three hours in his red, varnished "West Prussia," but as we approach him for the first time during this delightful Rhön air regatta he falls into an air pocket, sinks down hopelessly and, sad to relate, cannot recover his contact with the upper and more favourable air currents. As a compensation, however, he carries in his pocket the certificate of his Rossitten Duration Record of fourteen hours. The day before yesterday, Captain Köhl, who is spending a few days on the Wasserkuppe, was Schulz's passenger in the "Cöthen," but they did not have as favourable a wind as I am enjoying to-day but were forced to land after quite a short flight.

Now the slender "Hessenland" comes sailing some distance above us. She is the most graceful of them all, weighing, in spite of her tremendous span only one hundred and sixty-five pounds; from below she looks like a transparent flounder. It is a sheer delight to watch this bird, which is as light as a feather. Four times are we destined to meet these "aces" at different levels before the hour of our doom arrives. But that is not yet awhile!

Now we are hovering high above the flying camp. I see tents and more tents, large and small, and suddenly the people between them appear to me like Bedouins, moving about in long flowing robes in one of their tented villages; then the whole broad landscape beneath me is changed into a many-coloured, fantastic Fata Morgana. The soft warm wind plays about my body like a gentle massage, my blood flows hotly through my veins with an

intoxicant more potent than any bestowed by alcohol, while under the influence of our silent, effortless flight my imagination becomes here as free and wild as though it were bathed in champagne.

Fantastic ideas float through my brain. At one moment we seem to be nothing but a handful of white and brown shreds—a lifeless mass that the breeze blows hither and thither as it will. Then we go into a gentle turn, and it seems to me as if the machine's wings were attached to my hips so that I can move them coquettishly backwards and forwards, like the crinoline frocks of an earlier age that swayed so gracefully to their wearer's movements. But suddenly a glance to the depths snatches me out of my dreams, for I see that at this moment we are exactly above the hut, which stands on the highest point of the Wasserkuppe, at a height of three hundred and thirty feet ; we are careering madly onward and look like clearing the whole range at a single leap. Down below me at the starting place I recognize both my cousins and a host of acquaintances, all of whom wave to us with touching enthusiasm, but, when I try to pull out my handkerchief and wave back to them, I cannot, for my seat fits me so closely that it is absolutely impossible for me to get at my trouser pocket.

Next moment there opens before me for the first time the deep Lütter Valley, which lies on the north-west side of the Wasserkuppe. I know every tree and every bush in it, every meadow and every pathway. At the entrance to the village of Poppenhausen stands the farm of my grandfather, unchanged through many generations. All the long holidays of my childhood I, a town child, spent on this farm in this Rhön country, and those were the happiest weeks of my life. Not far away from it in the same Lütter Valley I can see the great bleaching meadows on which the Rhönland house linen was bleached before my grandfather took it to the fairs of Frankfurt, Aschaffenburg and Bamberg. For my grandfather was a Rhönland farmer and also a linen merchant.

But now comes the strongest impression of the whole flight. We are just hovering over the great meadow between the Wasserkuppe and the Pferdskopf, which lies nearly

three thousand feet high and belongs to an uncle of mine ; nearly a generation has gone by since I was first allowed to take part in what became later the greatest event of each summer holiday—the haymaking on the Wasserkuppe. Mowing is troublesome work up here, and the drive back to the valley with the heavily laden carts is a dangerous proceeding. The heaps of stones which we gathered as children are still visible on the boundary ; when I was nine years old, I lay for the first time all day long in the grass here, and there I saw the very first gliding flights. The Darmstadt students who suspended themselves in the air in primitive apparatuses, had to swing themselves aloft by running ; and I believe that one of them was Freiherr von Lössl, who was afterwards killed in a gliding accident, and over whose memorial stone we have just flown. Those first short gliding flights down the slope excited our youthful imaginations ; we dreamt of soarers who passed noiselessly through the air and saw the sky full of flying ships. In my soarer I shut my eyes and dream once again my boyhood's dream ; then I open them, and the dream has become a living reality. Seven giant soarers are gliding through the air, while the meadows round about me are specked with small school gliders, that look like great white flowers blooming on the green slopes !

We do not quite reach the Pferdskopf, that mighty pyramid which some god built as a proud and free buttress to the long-drawn range, for during our mad flight before the wind we have lost height considerably. And now comes something quite delightful. We have been riding for a little while upon a small cloud which galloped along the mountain slope beneath us and flung a phantom shadow that wandered with us down into the valley. But now the cloud flings off its proud rider, and we turn again into the wind above the bowl of the Gersfeld valley ; our speed decreases but an upward current enables us to rise somewhat. We fly above the road from the Wasserkuppe to Gersfeld at a height of six hundred and fifty feet, and I see this remarkable road with its long loops lying before me like the petrified curves of a whip lash.

We circle for a little while longer, but while I am still

busy with these sensible reflections my lovely fairy tale draws abruptly to an end. Near the source of the Fulda the upward current suddenly fails us ; something which I cannot see, though I can feel it, sucks at us and drags us down like a lift. Alex Schleicher shouts to me that he is going to land, and already we are gliding down steeply towards the starting place. Close above the ground he catches the machine up, flutters gently along for a few yards and then settles down upon the meadow as naturally as a butterfly upon a flower.

I cannot speak about my impressions of this experience ; I am dazed when I think of them, and I suppose it is an adventure that can only be granted to me this one time in my life. I have made ascents in free and captive balloons, and I have flown on many routes in all the better-known types of machine of the German Luft Hansa. Stormy flights in all kinds of weather and even forced landings are not unknown to me ; moreover, I have looped the loop several times with Germany's most famous war-bird and stunt pilot, Ernst Udet, and have flown all round Schleisheim Castle with the wheels on top and my head pointing earthwards. After some meeting or other Raab and Katzenstein once took me with them on one of their mad bouts of stunt flying, and we rolled and looped to our heart's content. I have often been asked which of all my experiences in the air has made the very strongest impression upon me, and till now I have always answered that it was a perpendicular spin with the engine opened full out, when you could no longer breathe, because at this velocity of over three hundred miles an hour the air seems to become as thick and hot as molten lead ! But from now onward I shall unhesitatingly say that it was a soaring flight from the summit of the Wasserkuppe over the Rhön !

SOME FLIGHTS OF MY OWN

I

MY RIDE WITH THE THUNDERSTORM

THERE was no specially good flying on the morning of that third day of the Rhön Soaring Olympiad of 1929. In spite of the unfavourable south-east wind everyone started for the altitude prize, which was the chief competition for the day. We had a lot of trouble on the south-east slope of the Eube ; often we found ourselves rising up, and then came a downward gust of wind from the Feldberg which flung us about wildly. The conditions were anything but pleasant, in fact, I found them so little to my liking that I landed after a comparatively short time.

Shortly before midday I was sitting in my machine, ready to try again, when a cry of horror went up. One of our friends had gone down in a spin and crashed into the Eube forest before the eyes of all the spectators. To get out of another man's way he had gone into a steep turn, but at that very moment a violent gust caught his wings, and he was not high enough up to get his machine under control again.

That sort of thing gets on one's nerves. I spent several hours with my friend who had fortunately escaped without injury. But the whole affair came as a shock to me and more or less spoilt my mood for the day. I had no intention of flying again, but shortly after three o'clock I went out to see what was going on. Some competitors came rushing up to tell me that Hirth was hanging more than three thousand feet above us, right in front of a splendid wall of thunder clouds. "It will be too late for me," I said to myself ; but nevertheless I wandered on to the summit, thinking that there would perhaps be time for me to have

a shot at the second prize of the day before the rain came. It was a competition for the best short-distance flight, the goal being the adjacent summit of the Ehrenberg.

The wind had dropped dead, and as I fastened my parachute belt, I felt that I must appear somewhat ridiculous in the eyes of the spectators for using one in such calm weather. Nevertheless, I packed myself and it into my gallant "Wien," which was barely able to contain us both.

While I waited to start, the windspeed indicator at the starting place pointed with consistent malice to zero. The storm approached and I felt certain that it must bring the wind I needed. But not a breath stirred the air.

The first heavy drops fell, and the numerous spectators fled, but still there was no wind. At last there came a gust; from six feet the windspeed indicator moved to eighteen. It dropped back to six, and then rose to twenty-four, whereupon I gave the word of command and flew off towards the Ehrenberg in a rising wind.

The altimeter rose so steadily that I deemed it unnecessary to tack over the slope. Up and up I soared, and when I reached the Ehrenberg I had attained a considerable height, though I was still some distance below Hirth. Then I turned and saw the whole thunderstorm front, which had been held up slightly by the elevation of the Wasserkuppe. Above me flashed the lightning.

It was a scene of wondrous beauty. The High Rhön lay before me as I hung waiting. The storm was overtaking me at a rapid rate, and I wondered whether I should be able to maintain my position before it.

At first it looked as if I would succeed in doing so. The mass of the Rhön mountains hindered the development of a regular front, but in the valley between the Wasserkuppe and Milseburg ragged clouds were rising rapidly so that any moment I might expect to find myself in the heart of the storm. Meanwhile the machine continued to soar, thus indicating the solution of my problem, for if it were possible to rise above the storm, it would also be feasible to fly along with it.

It was not exactly a comfortable situation, as there were far too many gusts for my liking. The machine was

violently shaken and flung about. The speed indicator ceased to function correctly when the first heavy shower came, and my glasses were dimmed by the rain, so that I had to discard them as useless. I was high enough up to feel the cold ; regretfully I thought of the jacket I had left behind me down in the close, thundery heat. But at the moment I hardly noticed its absence as there was far too much to do and to consider.

I realized at once that for me there was to-day no question of a flight along the slopes, which had now dwindled into insignificance. This time my slope was the front of the storm which assumed with ever-increasing rapidity the form of a mighty roller.

This first stage of the flight was literally a race with the storm. The altimeter rose to six thousand six hundred feet and higher ; as I flew over Geisa I gradually gained a bird's eye view of the whole front, which stretched from west to east and moved northwards at a tremendous speed. Beneath me I saw groups of little white clouds forming like clusters of grapes ; these showed me where the wind blew upwards. At a slant behind me lay the white roller, but I was still rising. To the north the country lay bathed in sunshine. Looking backwards, I sometimes saw villages reappearing behind the storm through the dark grey veil of the rain which followed it. In less than an hour I was high above Berka.

I had now flown somewhat in advance of the storm and waited for it to catch up with me. But it failed to do so, and, somewhat uneasy, I turned and flew along the wall, at first towards the north-west. I learnt later that Hirth had also flown in that direction. Soon I reached a curiously rounded cloud peak which lay beneath me. Looking closely, I saw that it was motionless. I turned, and realized, to my dismay, that the thunderstorm was split in twain. One half, which was dying down, moved to the west, which had hitherto been my course, while the other was heading eastwards in the direction of Eisenach and had already become wrapped in mists. Over Berka the weather was fine again.

If I can only manage to cross this gap, I thought, I

can fly on. Again I flew over Berka, but this time I encountered a downwind. I pushed the stick slightly, and the machine gained way. It seemed as if I might still overtake that half of the storm which was wandering off eastward. The split had somewhat spoilt the splendid frontage ; before me hung several black clouds which I strove to avoid. Then all at once everything grew strangely misty about me, as I had so often known it to do when sudden fog developed over the Kuppe.

It grew darker and darker, and suddenly I was in the midst of a thick white mass, so that I had the discomfort of flying blind. The speed indicator had swallowed water, and the whole machine dripped with moisture. I tried to steer my course by the compass ; for a while I was successful, but eventually the needle's movements grew feeble, and then it suddenly started revolving madly. From time to time a sharp gust drove the water out of the speed indicator's tube and the pointer began to function again quite gaily. Suddenly it jumped to forty ; to fifty ; I pulled my stick but still it rose ; I pulled harder, and yet my pace increased. The wind howled round the Vienna, setting all her joints creaking. I was pressed with violence against my seat's back, and though I pulled the stick right against my body, I could not decrease the speed. At that moment I was truly thankful that I had brought my parachute, as I had never before known such a strain on my machine.

All of a sudden the speed indicator went back to zero. I pushed the stick over but it seemed an eternity before I felt myself moving again ; then like a dream picture, fields and villages emerged from the whiteness and described circles, far below me. But a second later the curtain was drawn again, and so I flew onward for a seeming eternity. At last, however, I suddenly found myself once more in a normal position close under the base of a cloud. Eisenach lay beneath me.

I had again approached the storm front, which, as far as I could see, stretched away eastward. Far below me I then saw the last foothills of the Thuringian Mountains, around which I knew that I had to fly.

Soon a big town lay beneath me—I knew that it must be



35. THE PILOT'S SEAT IN THE "WIEN"



36. PUPILS PRACTISING OVER LEVEL GROUND

Gotha. I felt sure of it from my memories of what I had studied in my maps. Gradually I ascertained how far before the front I could keep my machine without losing height or exposing myself to over-violent squalls, and flew onward for a whole hour, keeping a south-easterly course.

I now began to feel discomfort from the water that had rained down on my hair, head and neck during the previous heavy showers. My teeth chattered audibly. How long was this flight to go on? It went on regularly and steadily. Such minor troubles, I thought, must often occur to pilots who fly long distances overland in power-driven machines, and so I held on my course to the south-east.

Often mighty clouds gathered in front of the rain storm, I flew round them but was sometimes compelled to push through them. However, I soon found that I was managing this blind flying better than at first.

As far as I could make out, the towns over which I flew must have been Erfurt and Weimar, but I am not sure. Then the front bent sharply to the south. It was already late. Visibility was bad and grew steadily worse. Darkness fell and I began to think about getting down. Wide plains stretched before me—partially wooded; I was over unknown country. I knew that the storm behind me must follow and therefore I looked out for some building where I might conceivably find shelter for my machine after landing. A town came into sight, with a fine field for landing just outside it and a big factory close at hand. I dropped down a bit and examined the whole situation carefully once more. The flags of a Gymnastic Festival which was being held there gave me an excellent idea of the wind's direction, and I could hear the shouts of the people. After a short glide I landed in Hermsdorf, not far from Gera, and nearly ninety miles from the Wasserkuppe.

II

A BLIND FLIGHT IN A SOARING PLANE

The Olympiad was drawing to its close. As regards the science of flight, it had taught us something new as

Hirth's and my own first deliberate flights with thunderstorms had demonstrated the possibility of utilizing the forces of the elements. Nevertheless we were not too well satisfied because we knew that not everyone would be capable of responding to the challenge of the thunder ; moreover, the typical weather which this kind of flying demands is not very prevalent. If distance flights were only to be undertaken by the aid of thunderstorms, they would have to remain exceptional performances.

Early on "record day" no flights could be started. Fog lay heavy on the Kuppe, and the weather appeared hopeless. The fog having lifted a little, the first man started soon after eleven ; but I still waited a while, for my "Wien" climbed so well that I should have flown up into the low drifting clouds immediately. For almost an hour the others wheeled about on the western slope.

It was a glorious sight. When at last I started, a whole squadron of soaring planes hung at the same height above the Kuppe ; then they all climbed. I decided to overtake them, one after another, and outsoar them.

For a while we frolicked in close proximity, then we strove to climb again. From the north-west a great bank of cloud came drifting towards us, and some of the machines flew to meet the first big cumulus. Flying under clouds had become a normal practice, and all pilots were skilled in it.

Suddenly I saw two planes disappear almost simultaneously into the deep, drifting, ragged masses. Matters did not look exactly encouraging, but there was not much time for consideration as the very next moment I found myself in the midst of the white milk-soup. Should I push down again ? It certainly seemed advisable. Of course I had left my parachute behind this time ! There had been no signs of any approaching thunderstorm.

The altimeter was rising. On the other hand it went against my flyer's pride to struggle down, so I carried on with my climb into the white infinity. Once more the compass began its strange circling movements, and the moisture was even heavier than during my recent thunderstorm flight. The speed indicator swallowed water and refused

to function under such conditions ; it whistled and squirted, indicating from time to time the approach of squalls, and then relapsed into inactivity. I sat erect in my machine, listening into the white nothingness in order to sense flight conditions by the tiniest piping of my bird. It was a crazy business, but I carried on, thankful at last that I was much fresher when I started this flight than on the day of the thunderstorm.

I looked at my watch ; a quarter of an hour had passed, and I had lost all idea of time. The altimeter had been rising continuously, so that at least there was no danger of running into a mountain top in the clouds.

Half an hour later I was still flying blind ; I had to believe my watch on this point though the time had seemed four times as long. Then it grew clearer around me, only to darken again a few moments later. Shortly afterwards several violent gusts flung the machine up and down again ; I felt I was sitting on a see-saw. Lighter and darker intervals succeeded one another ; then came a sharp gust that compelled me to pull the stick, and I rose into radiant sunshine !

I believe that up to that time I was the first successful soaring flyer to rise above the clouds in a motorless plane. Never before had I seen the cloud ocean from above, and the contrast between their aspect and the conflict from which I had emerged enhanced the view in my eyes. Below me lay massed the cumuli through which I had flown ; between the two nearest was a narrow gap through which I slipped quickly with my machine. In this way I sprang from cloud peak to cloud peak, looked for holes in the cloud ceiling through which I might see the ground in order to obtain some idea of my whereabouts, and turned away again when some bulky fellow threatened to swoop down upon me or to stop up a gap. Then I set off, flying with the wind as far as possible without climbing through great clouds. From time to time I could fly a little higher, and although at first I tried to slip through between the cloud peaks I soon found myself flying calmly just above the clouds, for they bore me perfectly. So wonderful was this flight that for some time my thoughts neglected to formulate

a plan, but at last I decided to search for the biggest gaps in the cloud ceiling and endeavour to get my bearings by the courses of the rivers and the contours of the country that I could see spread out below the frame of billowy white clouds.

The pictures which I then saw have become part of me for ever. I almost regret that now all I have to do in order to see them again in a few minutes is to fly up in a power-driven airplane. Familiarity has made an ordinary thing of what was then a wonder, a glimpse into the land of dreams and fairies.

I now recognized the country beneath me and knew that I was approaching the Frankenwald. With my clouds I was sky high above the falling wind currents of the Rhön after a flight of over forty miles. In my efforts to reconnoitre my position I lost height and found myself sailing just above the lower clouds and close to their towering peaks, but later I circled in my old accustomed way under lonely clouds floating at a higher level. The wind was favourable and I saw that I could glide swiftly to the slopes of the neighbouring mountain chain, but soon I was forced to conclude that the gods of the weather had entered into a conspiracy against me. It grew very cold ; rain hung in long streaks over the landscape ; clouds, rain and mist made the visibility bad. How I found my way under such conditions I cannot tell ; in the words of the trite expression I " followed my nose."

Only once I nearly lost it. A weathercock deep down in a valley pointed in a wrong direction, and I followed its advice, which led me into a maze of hills. Suddenly I felt a heavy downward gust, which made it plain to me that if I proceeded much farther on this course there would be a speedy end to my flight. So I made my way back, with much trouble, along a winding river valley, slipping down more and more, and emerging at last from this detour, which had cost me more time than I had realized, some hundred feet above the little village where the weathercock sent me astray. I sat in my pilot's seat as if on pins. It seemed impossible to reach the nearest hillside from this height, and in my despair I looked about me for a landing

place. Then I saw before me, a little to one side, a hawk soaring high on an upward wind current. At once I flew to the spot; the guidance given me by my diminutive rival in the air had come at exactly the right moment, for my big bird immediately climbed some seventy feet, a height which just enabled me to reach a timely slope. Gradually I worked my way up again and set off once more on my course to the Fichtelgebirge.

Unfortunately the mist was so thick about those mountains that it was useless to think of trying to fly over their crests. I had to drop and creep along by the foot hills as well as I could, and yet just this work—tedious enough from the flyer's point of view—gave me great pleasure. Once I raced a little local train that ran in among the hills, puffing heavily. Another time I hung over a small village to gain height, and lingered there till the last inhabitant stood gaping in the market-place. I could even hear their shouts rising up to me in an indistinct murmur.

But the weather was not behaving well. Tattered curtains of mist hung down to my level, some of which were caught and held by the forest. Down in the valleys, where I was now forced to fly, a gusty wind blew which smote upon my wings with ever increasing violence and frequency. But this did not disturb me much, for a little while before I had seen Bayreuth in the distance and thus gained the satisfaction of knowing that I had brought off a really long flight.

With nightfall came heavier rain; the wind was squally, and some whirling gusts that hurtled out of side valleys gave me more than enough to do. I had now been in the air six hours, and could only distinguish the outlines of the nearest mountains. A high-tension wire which loomed up before me out of the mist and darkness, the poor visibility and the general gloom of the night drove me at last to land in a marshy meadow.

Later calculations proved that I had secured two new records, having beaten my own thunderstorm flight of ten days earlier in both height and distance.

III

SIXTY MILES ALONG THE TEUTOBURGER WALD

As was to be expected, the announcement of the *Grüne Post* prize caused great excitement in the breasts of successful soarers and those who still waited on success. Anyone harbouring designs upon this prize went to work in all secrecy, and consequently very little was heard of the many attempts to fly the sixty miles. Only from time to time came rumours that in this or that part of Germany a certain number of miles had been flown, or that a plane had crashed, or that certain aces were waiting patiently but despairingly for proper sixty-mile weather. That autumn many wonderful thunderstorms passed over the Wasserkuppe, many splendid cumuli invited me to start. Many a time, when on duty as a flight instructor on the Kuppe, I stood with stop-watch in hand, following the aerial exercises of the "C" pupils, and thought that surely someone somewhere in Germany was "taking off my beard," as we say in flyers' slang. But nothing happened, and I gained time. Winter came; soaring hibernated. In spring I extracted my new steed from its stable; on my first big flight I gained a high altitude which induced me to look forward to future events with a certain degree of hopefulness. At the same time Nehring began his attempts to win the great prize from Darmstadt, and his successes on long-distance flights far outdid my own.

It grew clear to me that in face of such sharp competition and taking into consideration the magnitude of the enterprise, only the fullest exploitation of the knowledge gained in my soaring experiences, coupled with a careful choice of country, and, last but not least, an indispensable slice of luck, would afford me any hope of success. A study of the map of Germany soon showed the best neighbourhoods, and I cudgelled my brains as to whether I should select the classical German soaring region of the Rhön, Nehring's sphere of activity on the Bergstrasse which extended into the Black Forest, or seek out for myself some new and

unknown territory. In spite of its special advantages for me, purely sporting considerations forbade me to choose the first of these alternatives.

There is always a special charm about flights over new regions and I longed to prove that the prize could be won by such a flight. It seemed undignified to choose a route already tried out by another man, and so I made up my mind to take the third alternative. The Teutoburger Wald was a romantic range which always had a strong attraction for me ; there where in olden days the Roman legions under the hitherto invincible commander Varus had been defeated, there I would fly. The Hermann monument in honour of the Teuton leader who had gained the great victory became a symbol for me.

Unhappily my first attempt, which ended miserably by my dropping down into a hole between two hills after having flown less than twenty miles, was not of very favourable augury. Sorrowfully I returned to the Wasserkuppe after three days in the Teutoburger Wald. After three days of wasted leave and a night journey I was almost prepared to agree with those people who maintained that there was little to be gained by flying on these low hills which rose only about three hundred feet above the surrounding plains. Then a telegram arrived from the weather station there :—" Weather A. 1 ; start at once ! "

I resolved to make one last attempt and bring my machine back to the Wasserkuppe if I failed. Again I spent a night on the seat of a railway carriage.

My sporting friends of the Teutoburger Wald had done wonders ; when I reached the starting place, my machine was ready for flight. Weather conditions, too, were most promising ; the wind-speed indicator showed a velocity of from twenty-four to thirty-six while cumuli were to be seen in the sky. They were not the exactly right kind of clouds, for they were small and tattered, but they were better than the cloudless blue sky of my first effort. The large gaps to be found among the slopes of these hills could only be bridged by the help of upward cloud currents. This fact was indeed amply proved during my flight.

On May 15, 1929, at 10.40 a.m., the valiant " Wien "

sailed off into lucky air, though at first matters did not look too favourable. The launching crew flung me into the air spiritedly; the lock keeper, who was busy on the ship canal below, waved to me. The good man, I learned later, had given orders to his men to hold their boats in readiness. None of them had yet seen soaring flights, and they were confidently expecting to have to fish me out of the canal. No wonder their chewing tobacco nearly choked them while they gaped up at the engineless bird that climbed so silently towards the sky.

The limited updraught surfaces of the low slopes allowed me no great freedom of movement. Ever and anon I was compelled to seek aid from the clouds floating overhead. At Lengrich, a most troublesome spot, I lost considerably more time than on my first flight; as it was comparatively early in the day, the houses of the town and the sides of the cement factories there, which lay baking in the sun, had not yet gathered heat enough to give off such warm currents as they had done on the occasion of my former flight, which took place in the afternoon. For three quarters of an hour I crawled crabwise in uncomfortable proximity to the factory chimneys, which loomed ever closer until at length I managed to catch a cloud which carried me over the place. It was a piece of luck, as I was not feeling exactly happy at the idea of having to settle down on the lightning conductor of a chimney. In the same way I passed with a scornful smile over a spot which had nearly been fatal to me on the first flight and then later over one of the most difficult stretches near Rothenfeld, where the foot hills weaken the updraught appreciably. But the clouds were not very accommodating that day, and it proved impossible to attain genuine contact with them and sail on by the sole use of the upward currents beneath them.

Outside the large town of Bielefeld things became easier. It was comparatively simple to sail along the slopes, which were everywhere thickly wooded, helped by a half wind from behind. Many motor-cars had followed me and overtaken me at places where I had to linger for any length of time, but now I lost them altogether. Unluckily I lost with them the clouds of dust which they created, which were my only

possibility of observing accurately the change of wind that unfortunately took place. Then I saw some fine cumuli puffing themselves out ahead of me—heat clouds overhanging the heath. From the great Hermannsberg I tried once more for my higher contact and now succeeded in obtaining it perfectly for the first time that day. And very necessary it was, too, for beneath me the trees seemed to stretch endlessly ; a forest which I guessed to be some four or five miles broad and of incalculable length made all thoughts of landing impossible. I saw the Hermann monument in the distance and steered directly for it ; here I found that the hillsides sloped more gently while the range bent to the south.

The foothills were so steep that it became impossible to soar by the help of updraughts from slopes. And now again the cumuli proved themselves anything but reliable assistants for I speedily lost all the height I had gained. The treetops drew dangerously near ; matters threatened to become critical as I fell and fell. I turned farther eastward, but all of a sudden came a downward gust that pushed me to within fifteen feet of the branches. I began to look out for a place among them where I could build myself a nest.

In order to save the machine I saw that I would have to go back some five miles to the last good landing place I had noticed. Heartbroken, I turned away from the sixty-mile limit I had so nearly reached, but just as I put the machine into the turn I saw dimly before and above me, far away from the slope, a tiny tattered rag of mist of the type that crowns a weak warm air current. Here was a forlorn hope. If I could gain about one hundred and sixty feet, I should be able—provided that I turned at once—to dodge along under the cumuli now travelling swiftly over the ridge. The bronze Teuton warrior, past whom I had to return, raised his sword dangerously towards the heavens, and I was so low down that I nearly ran down (or rather flew down) good old Hermann.

The town of Detmold came into my field of vision on the left of my route, and the vital question was : would the clouds be strong enough to overcome the downdraughts

of the slope? They were, and so I pushed on for a long time in the boundary layer between the up and down winds. When one or the other happened to catch me, I was violently tossed higher or lower, so that I had little time to think of choosing a landing place. A last turn, which brought me round in the direction of the valley, enabled me to gain another short stretch with the help of wind and gliding angle, and I landed with the wind behind me in a cloud of dust on a ploughed field. The first sixty-mile soaring flight was at an end.

Hallo! Was there a fair in the neighbourhood? Many people who had seen me flying had no idea that this was the first sixty-mile motorless flight, that it had succeeded, that the greatest of the soaring flight prizes was won. Only their enthusiasm had brought them along; the impression created by the silent passage of the giant bird had been so irresistible that workmen left their workshops in their blue overalls, and, annexing the first motor car or cycle, had followed the airplane. And now they arrived one after the other. What rejoicings and congratulations were showered on me from all sides!

I was so dead tired that I could hardly take in the general rejoicing. The whole evening I was dragged from one festivity to another; in the midst of a long congratulatory speech somewhere or other I must have gone off to sleep. I here and now take the opportunity to beg the kind friends who were present to forgive me.

One among the many telegrams bringing me greeting and good wishes that day I shall remember as long as I live.

Here it is for you :

That Teuton land, which once o'ercame me,
Sent thee up to victory fair :
I gladly from my tomb acclaim thee
Victor o'er the powers of air.

QUINTILIUS VARUS
(Erstwhile Roman Commander).

Spiritualists would maintain that old Varus himself, clad in clinking harness, took this message to the post. Personally I believe that it was some jolly wag in more modern garment.

IV

SOARING IN A SNOWSTORM

We are used to all sort of things up here on the Wasserkuppe in the Rhön, but snow and icy cold in May cannot be called comfortable. And just this was the moment chosen for a visit to us by an American pilot who wished to study European flying on the spot ; in two hours and thirty-five minutes—he had precisely that amount of time to spare—he desired to gain an insight into the aims, objects and importance of soaring, to see the Research Institute, the School, and, if possible, see a flight.

Should we excuse ourselves on the ground of bad weather ? Herr Stamer, the chief instructor of the Flying School, looked at me questioningly. “ Are you inclined to fly ? ” said his glance, but I felt really inclined to make an attempt. We had there twenty new pupils in the beginners’ course, who had not yet seen soaring.

They brought the “ Prüfling ” out to the western slope. The American looked on suspiciously. Ahead of us a snowstorm scudded along over the steep slopes, while far below us we could still see the village of Poppenhausen. The snow began to drive horizontally. “ Nowhere in Germany would an engine-driven plane be allowed to start in such weather,” said an air policeman who was on duty. The American grew very quiet.

The launching rope was hooked on ; twelve men pulled on it, while two held the plane from behind. “ Let go,” I shouted. My “ Prüfling ” shot violently forward and at once began to rise. “ A damned strong wind to-day,” thought I. Excuse the expression, but we really do think like that at such moments. I moved forward very slowly, with the snow whipping me in the face. It was stubborn work ! Great gusts and eddies of wind met me from rock and forest, buffeting me from in front and below—a hard battle. The machine danced in every direction, the lever in my right hand jumped from one corner to the other. But the plane climbed. I rose three hundred feet above my starting point and found the wind up there still stronger. I had to

press the "Prüfling" in order to make any headway at all. Now I could make out below me the sharp edge of the slope. Time to use the rudder! My left foot pushed the pedal forward, the world flew down around me; the whistle of the wind in the struts changed its tone as I turned to the left slowly and began to ascend above the edge of the slope which flung the wind up to me. I was now seventy feet above my starting point, and the wind was steadier except when (often enough) I got into "a lift." Then I was shot straight up suddenly thirty, or even sixty feet.

The flurry of the snow became thicker; through it I could just distinguish the steep ridge of the Pferdskopf. I turned about; for one moment I stood again head on to the storm. How the snow crystals stung my eyes! I took the plane out of the turn and noticed that the slope beneath me was hardly visible through the driving snow. That meant that I had risen farther; I was in the clouds. I had to push down a bit in order to be able to see the ground beneath me. Hallo! Flyers' Monument, launching crew, starting place—small as toys, far below! So turn again!

The wind had changed and was blowing from the Pferdskopf. My eyes burned and smarted; should I put on glasses? What was the use? The snow would only settle on them. And again I flew towards the Pferdskopf, slowly, infinitely, slowly for hours. . . . Ten minutes, said the watch. Turn, slabs of fog, squalls, turn. In long white strips the snowflakes pelted horizontally out of the endless grey; I saw long white strips, nothing else. And I felt them like sharp pointed arrows. The cold mounted slowly from my feet upwards. A turn, another . . . twenty minutes. Will it never stop snowing? Grey, nothing but grey! It was only possible occasionally to distinguish very prominent landmarks on the earth below, but I began to experience an amazing indifference. I had a fervent longing to shut my eyes and dream. I pulled myself together, grasped the lever firmly, and steered from turn to turn, fighting the cold, the storm, the fog and the snow.

And then I was forced to recognize that to-day nature would not yield. Thicker and thicker the fog rose up from below,

mingling with the snow as it drew closer and closer. It was high time to go down. I descended in spirals; the slope whirled up to meet me. Once more I had to pull myself together for the landing. Up the slope with the wind behind; look out! rocks to the right! rudder! now push! Thirty miles an hour was the wind speed, my flying speed about forty-five—that meant a landing of at least seventy miles an hour.

Look out! a stone in the way! I move my stick slightly and clear it! Rrrrschsch—the skid scrapes along the ground; the swing drags me forward, but my safety belt holds me firmly; then peace! I have done it!

And then, after I had rubbed the snow and ice from my eyelashes, I looked at the watch, which registered a fifty minutes flight. The starting crew came hurrying up; the flight leader and the American congratulated me. Why? The only things I was conscious of at that moment were stiffness, smarting eyes and a feeling of something splendid, indescribable. . . . Before they ordered me off into the warm house, I asked our American, who, like everyone else, was in a somewhat frozen condition, what impression the whole business had made upon him.

“Greenly Island,” said he dryly.

Later I learnt that he had sat all the time on a stone, in the storm, watching the machine whenever it was in sight, and dumb with astonishment at the miracle of soaring. And down below in Poppenhausen he ordered from our flying machine constructor two soaring planes, express. “My boat sails in three weeks, and I must take them across with me.”

THE GLIDING AND SOARING SCHOOL

WHAT a bustle! What a hullabaloo! A new batch of young folk has arrived at the school and throngs round the instructors, asking a thousand questions, each of which demands an immediate answer.

“How do you land?”

“Do you push the stick much to one side when you make a turn? Do you pull it hard when you want to soar? What must I do if the machine heels over? What do I do when I start? How do I hold . . .? What . . .? Why . . .?”

Every one has a difficult problem, but we instructors pay no heed to them, for we know that everything comes with practice. “Flying is all a matter of feeling and habit,” we tell them, “don’t try to think too much; only the swift, subconscious reaction which is more or less inborn in all of us will help you at first. Later, when you can do the big things, you may use your brains. And now, just be quiet. What you have to do first of all is to settle yourself calmly in the machine and follow your teacher’s instructions.” We then treat them to the few words that we say at the beginning of every course. We do not tell them more than the bare essentials because we do not want them to be thinking when they should be learning to feel. “Settle yourself comfortably on your seat,” we say, “and put your feet on the rudder-bar. Take the control lever in your right hand—quite lightly—don’t clutch at it. Everything must feel quite comfortable and unconstrained. Sit as you would in an armchair. The stick you can manipulate so easily is the flyer’s magic wand; think of it as a force that propels the machine in any direction. It is your job to make it guide your plane wherever you want it to go. Look at the horizon and take some point that you can easily keep in sight. Look at it steadily and remember that as you see it now, so you must see it when you are in

the air. If the machine rears up, push the stick forward a bit to bring it to the level again ; if its right wing dips, push the stick to the left ; if the nose dips, pull the stick towards you. All your movements must be quiet and efficient. As regards your lateral steering, better not worry about it at present, but if your machine goes into a turn, which you can easily tell by noting the position of your fixed point, then press the rudder-bar on the other side ; that is to say, if you find yourself turning left, push the right foot forward and vice versa.

“ But you must do everything smoothly and without any fuss, and you’ll find this much easier than you think. Your instincts will help you far more than they do when you’re steering a car. Now come along and have a shot at it.”

One of them takes his seat in the pupil’s machine, which we have brought to a perfectly level spot. The wind for these first efforts must be only a gentle breeze, with a velocity not exceeding twenty feet a second. On either side of the launching rope are some three or four men, waiting to start.

Before the novice takes off, I show him the neutral position of the control lever (“ stick ”). “ Now press just the least little bit,” I tell him, “ no, that’s too much. Ah, that’s right.”

It is usual for the pupil to give the words of command at his first lesson. “ Pull out ” he cried, usually with some hesitation. The crew walk about eight steps. “ Run,” is the next instruction, but some pupils can get no further than that, and often I have to interpose with a hasty “ let go,” to prevent the rope breaking.

To be a good teacher of soaring you must be able to divine the feelings and secret reactions of every pupil from the way his steering affects the planes. All teachers must practise the graphology of the air from the moment they give their first lesson.

This affords plenty of opportunity for observation. One pupil does simply nothing at all, does not push the lever the least bit, but the machine flies perfectly. Five or six seconds his first flight lasts.

“ How did you feel ? ” I ask afterwards, and the man who two minutes before had been crouching in the machine, hardly venturing to touch the controls, replies : “ I started nicely ; then came a gust from the right ; I moved the rudder, noticed that I pushed it too far, adjusted it, pulled the stick a bit and steered sideways. Then I got ready to land.” It is extremely difficult to convince him that he has done none of these things, though he may have imagined himself doing them.

“ Have you ever dreamed that you are being pursued ? ” I ask him. “ You want to run, but you can’t. You believe that you are exerting all your powers, but in reality you are doing nothing at all. That’s what you and most beginners are like the first time you’re in the machine.”

The next pupil pushes the stick a bit too hard when he starts, and the machine comes down with a bump after a flight of less than twenty feet. “ First I saw everything blue around me,” says the man, “ then it all changed to green, and finally the machine crashed.” He at least is honest.

The most difficult pupil is the one that starts by doing everything wrong. The machine rears, but instead of pushing the stick forward, he pulls it. The machine continues to rear ; he pulls it further until it is almost standing on its tail. It hangs in the air for a fraction of a second, and then drops earthward like a ripe plum. No great damage is done as the fall is merely a matter of some twelve feet or so, because we always start our beginners on level ground, so that the worst that may happen is a broken wire or two, while man and machine are certain to escape serious injury.

“ What did I do wrong ? ” asks the unlucky fellow. “ I meant to push the stick over.” He may be one of those persons who cannot grasp the simple action of the control lever, and to such a one you must try to explain matters in some other way. “ Imagine that you are in a kayak or some kind of light boat,” you tell him. “ A high wave surges up before you ; what do you do to balance your boat ? ” “ I bend forward.” “ And on the same principle you bend sideways if the boat lists. If you can’t learn it any

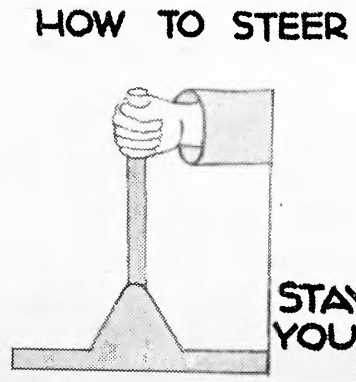
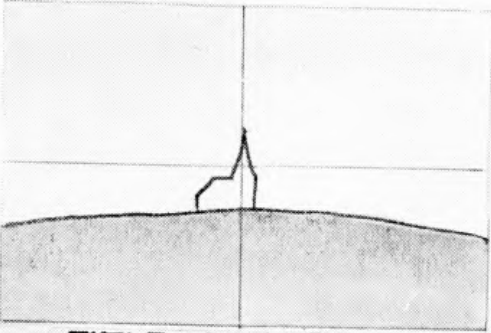
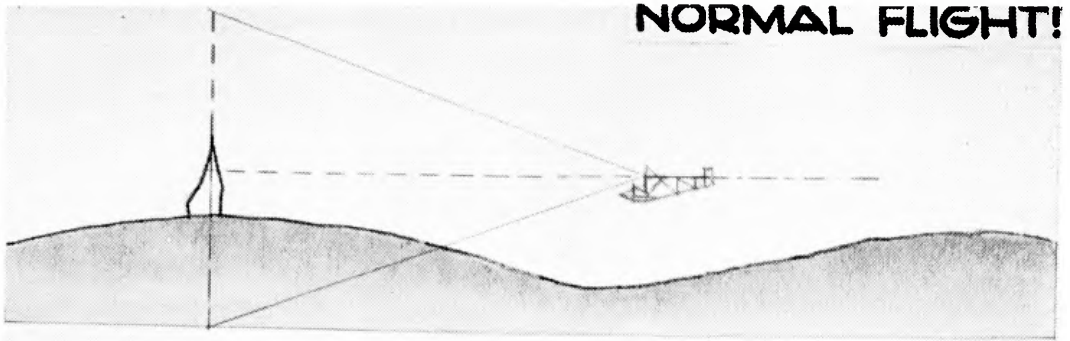

R. KRONFELD

37.

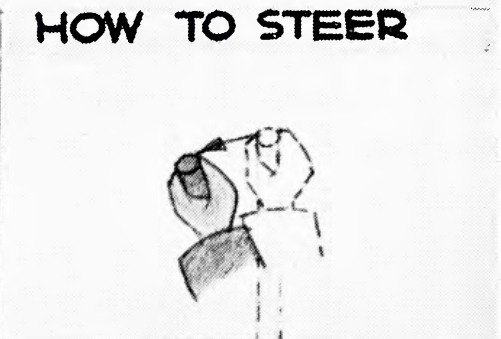
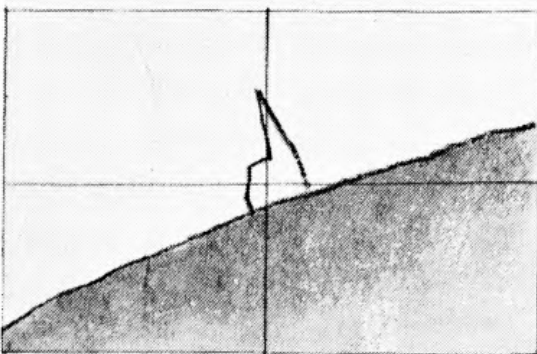
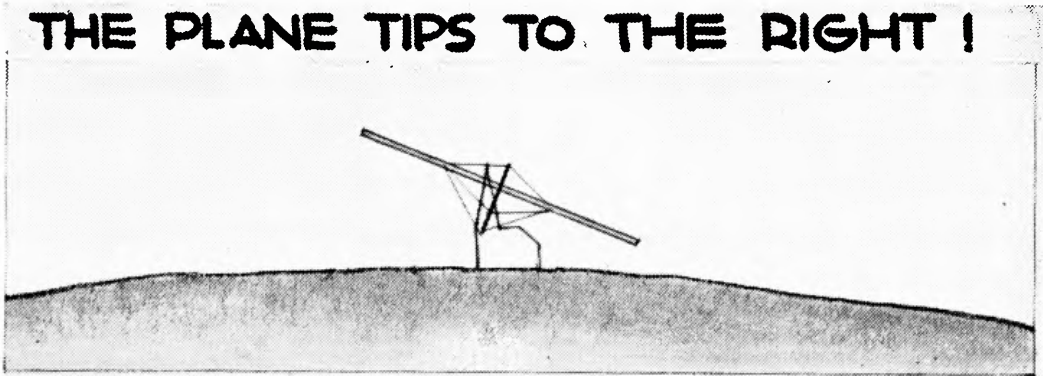

R. KRONFELD

38.

THE PLANE TIPS TO THE LEFT!

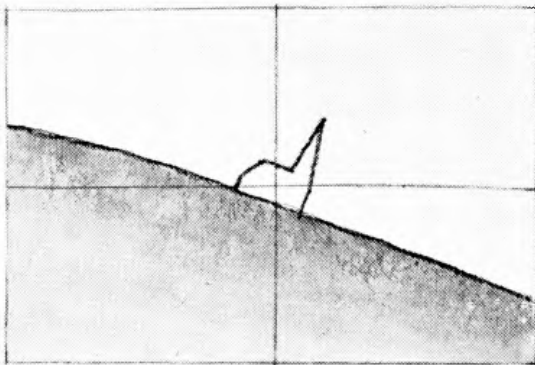
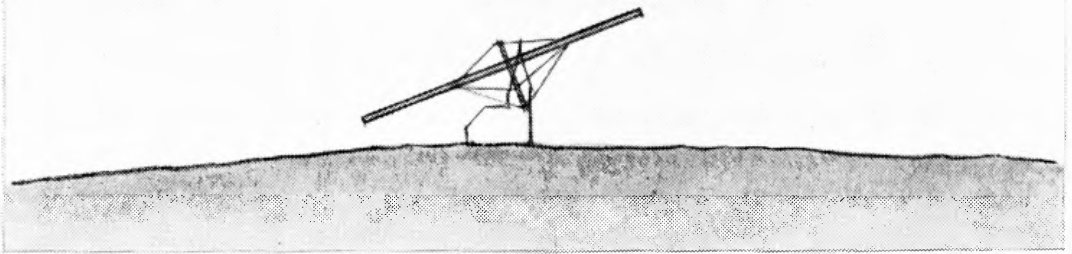

FIELD OF VISION

HOW TO STEER



LEVER
TO THE RIGHT!

R. KRONFELD

39.

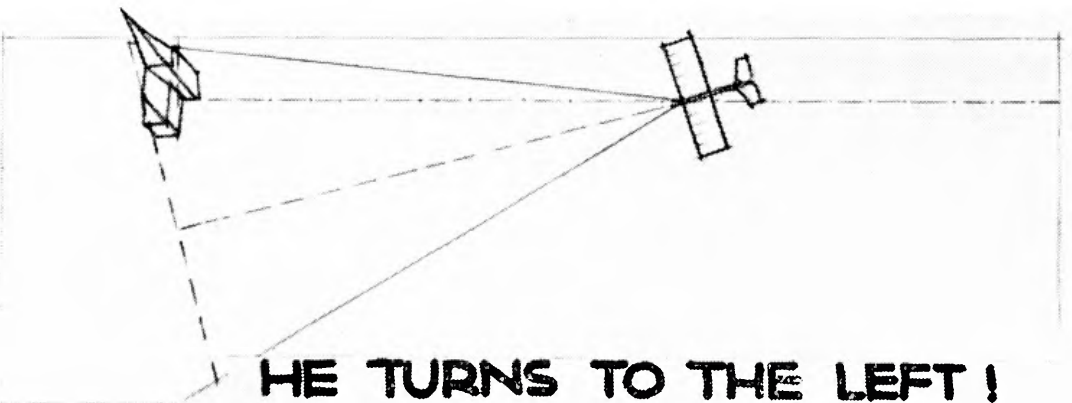

HE TURNS TO THE LEFT!

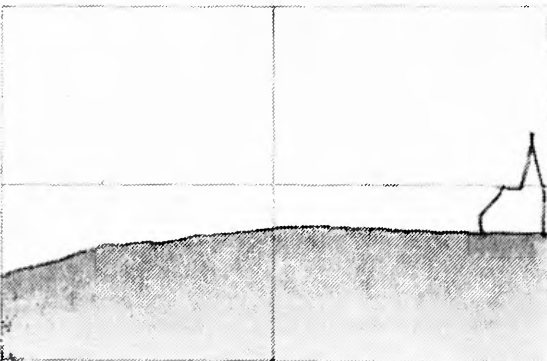

FIELD OF VISION

HOW TO STEER

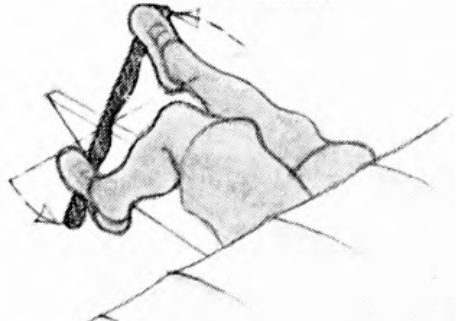

RIGHT FOOT FORWARD!

R. KRONFELD

40.

other way, try what you can do by bending your body in the machine, and while you do so, accompany the movement with the hand that holds the lever. It's a trick that will help you at first, but you have to get out of it later, of course. But in most cases it works well."

Most beginners do not realize what they do with the stick. The first essential is to get them used to the method of starting, and you can draw your own conclusions from the way in which a man seats himself in the machine. One perches lightly and gracefully, another assumes a cramped attitude; many are so excited that they forget to strap themselves in, fidget restlessly or remember some question that they want to ask just as the machine takes the air. The trembling of a pupil's toes often tells tales of nervousness that he is striving to conceal.

The instructor must endeavour to adapt himself to the idiosyncrasies of all pupils. His practised eye will tell him how many of them will behave in the air before they enter the machine, and it is a mistake to think that only the good sportsman will fly well. Flying is far too much a matter of feeling.

The average man who reacts well (every normal pupil in fact) will over-steer at first, because it is man's nature to react quickly to great and sudden impressions. In flying every movement of the machine will seem twice as great as it really is because of the pupil's excited state. Initial nervousness will cause him to exaggerate his manipulation of the stick, and consequently both machine and pilot are in a state of continual unrest; they tip over from one wing to the other and dance up and down until the pilot is completely confused.

"I cannot get the machine steady; there are so many gusts which fling it about." You hear that again and again, even when hardly a breath of wind disturbs the air. "Personal gusts" is the term we use to describe the state of mind of the nervous flyer whose incessant jerky movements lead him to think that he is flying in gusty air. "You must take it easy," I tell him. "Don't grasp the control lever so fiercely; no force is needed; you can steer with two fingers. Let the machine fly by itself at first, and you will

see how steady it is. It can always keep itself rightly balanced without any interference from you."

Then the pupil flies again. The teacher gathers the others around him, and shows them the good and the bad examples.

"Look how steady the machine is," you say when you watch the best of them. "That fellow is taking it easily, and you must all try to imitate him."

One after the other takes his turn in the machine ; at the fifth or sixth effort they begin to make progress.

This is a typical description of the first day's work. In the evening our machine is put on the little two-wheeled trolley and taken back to its "stable."

Very early next morning we are out on the flying ground again. By this time groups have sorted themselves according to age, temperament and talent. Ten or twelve men to a teacher is about the right number.

To-day there is a light breeze, and we proceed once more to the slight slope, where each pupil tries a "hop" in which he uses his controls as little as possible. Most of them show signs of improvement.

Then I set them a new task. "As you have learnt to take it easy, try a start from this six foot elevation, and practise all the steering movements, one after the other. First the elevator ; start, fly quite quietly for a moment, then push the stick down a bit. Take it quite easily, and don't move it more than the least fraction. Before you land, pull it a bit to decrease the shock, and you'll see how beautifully the machine answers to the least touch. When you have done it all right, try the ailerons, but take care to avoid all other steering movements in order to realize the operation of that one alone."

They soon do it quite well, Then comes the rudder, which is every beginner's bugbear.

"Do what I will, I always get out of the straight course without meaning to do so ; I lose my fixed point," someone complains.

"Just notice how each man sits and what he does with his feet," I advise them. And so they all observe that the pupil about to start is pushing the rudder bar convulsively

before he has left the ground. In the air he makes matters worse by kicking it savagely—as though trying to break it.

Most people have one leg a little stronger than the other, and perhaps the man is not sitting quite straight in his seat ; at all events one foot is thrust too far forward, and so he steers lopsidedly and uses so much force that he loses all power of feeling its movement. All through his flight he is fighting against his own strength, while the machine calmly goes its own way.

“ Why ? ” a pupil will ask.

“ Sheer nerves,” I reply. “ Everyone is afraid of falling from his seat unless he plants his feet firmly against something. Strap yourself well in ; now try before you sit down to lift your foot up from the rudder bar. That’s right ! You must gain a quite fine touch and be able to play with all the controls.”

Often, however, errors in lateral steering have other explanations. In a flying machine change of direction is obtained in exactly the opposite way from that used in a motor car, motor cycle or bicycle. If we want to turn to the right we must push the lateral control to the right and forwards—not backwards as we do with the steering apparatus of vehicles on the ground.

All day long pupils start again and again, and now we answer all their questions promptly. One of them, who promises well, can already fly from ninety to one hundred and twenty, or even as much as one hundred and eighty feet. After every flight the pupil must report himself to his teacher, and recount his impressions and listen to our criticisms. It is forbidden to discuss the flight first with fellow pupils.

From his behaviour in the air and from what he tells us we can speedily form an opinion as to the improvement in his powers of reaction and observation, but there are often pupils who do not know in the least what they do or how they do it, and yet do just the right thing unconsciously.

“ You will be a real flyer when you dream of steering, for such dreams will show that flying has become a true part of your subconscious self,” we tell them.

And here we find a way to help even untalented pupils

to learn to fly. There is in every group at least one who has no flying sense whatever, or who thinks and acts very slowly ; and often just such pupils are the most diligent and enthusiastic.

At first none of them can make calm and accurate observations. Instead of the sky they see "blue," instead of a meadow, "green." But later, sometimes after only two or three "hops" their minds are freed from nervous misgivings and they see the sky with its clouds, the horizon and the landing place.

But not all are so fortunate. One says : " I can't do things so quickly ; before I can see or do anything I am on the ground again."

When practice fails to benefit a backward pupil, there is only one chance for him, and that is to learn to fly by pure reason. He must form in his mind an accurate picture of every movement he has to make in the machine. " This you must do partly from my explanations," I tell him, " and partly from what you observe when others fly. The condition of the machine, its position in the air, yourself, the control lever, the rudder-bar—you must be able to picture them all clearly in your mind's eye. For example, describe your impressions of what happens when the machine rears."

" The horizon disappears downwards ; I can't see the ground, only sky."

" What must you do in such a case ? "

" Push the stick forward."

" Good, but that is not enough. With your eyes shut, at any moment, wherever you may be, you must see the steering movements just as clearly as if you were sitting in the machine. You can practise while you are eating or in the tram or in the pauses of your daily work. You must do that until by constant mental practice the movements become second nature to you by passing into your flesh and blood, so to speak."

Talented pupils learn the correct use of the controls by merely spending a few moments in the machine, but the man who acquires no flying sense instinctively must conquer his difficulties by the aid of his mind. We know

HE TURNS TO THE RIGHT!

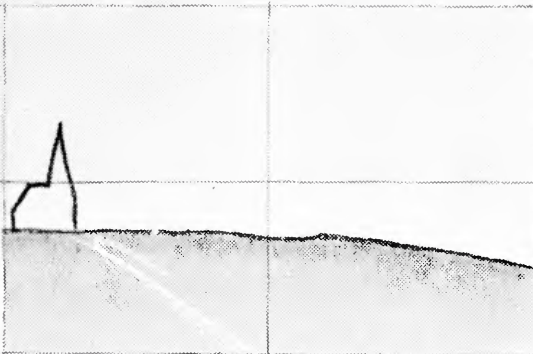

FIELD OF VISION

HOW TO STEER

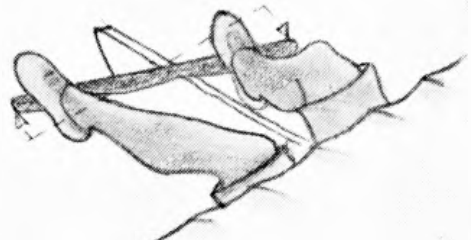

LEFT FOOT FORWARD!

R. KRONFELD

41.

FLIGHT TOO RAPID!

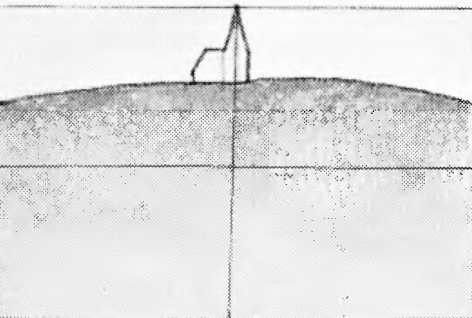
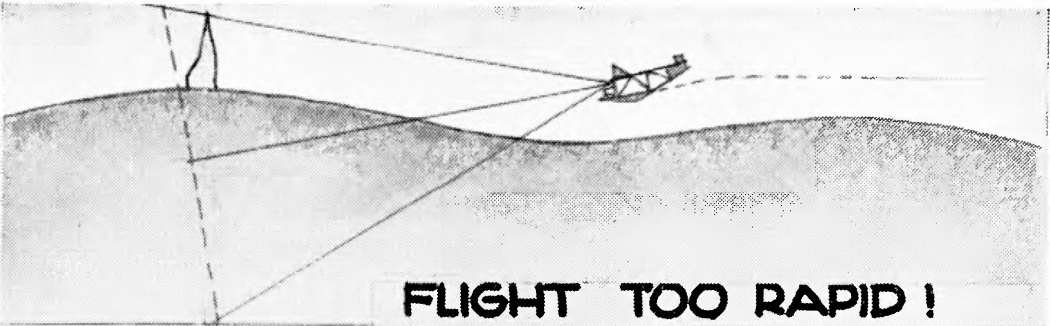

FIELD OF VISION

HOW TO STEER

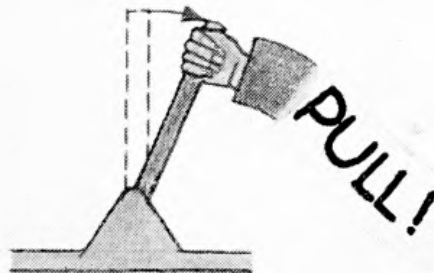

R. KRONFELD

42.

GLIDING FOR A STALL !

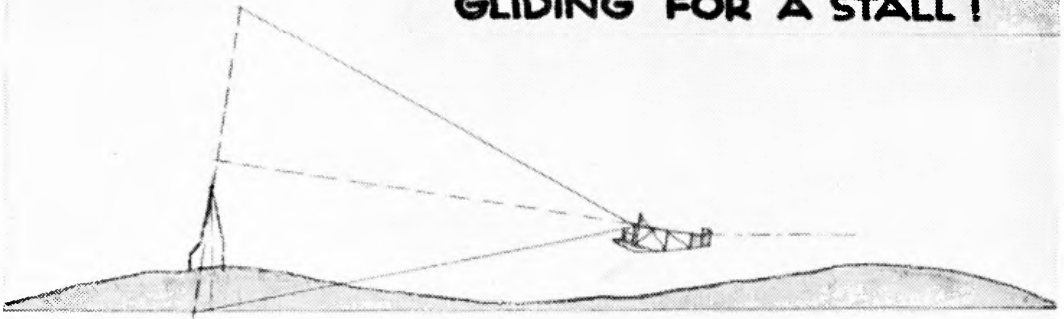

HOW TO STEER

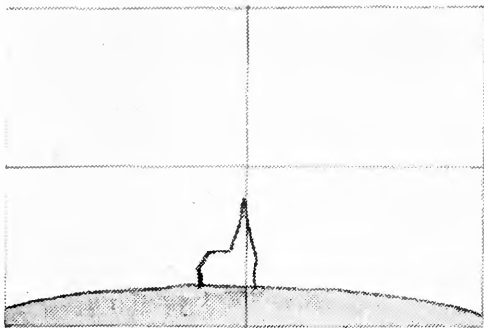

FIELD OF VISION

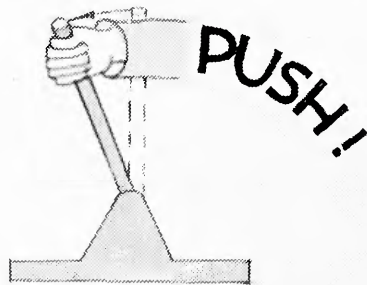

R. KRONFELD

that some celebrated aviators, including many stunting experts, always visualize their most complicated evolutions in the mind's eyes before they attempt to carry them out. This power of visualization is a very effective help in time of trouble, when perhaps a number of different actions have to be performed in a few seconds. In such cases the more that can be done at the prompting of the subconscious self or as the result of mental training, the freer will be the pilot's body and mind to grapple with the situation and so save his life.

The beginner who encounters a sudden gust and the experienced pilot who finds himself confronted with a wall of rock when flying in a fog experience similar sensations. Each is up against a problem that calls for the utmost exertion of all his skill and knowledge, and the time allowed him to make up his mind is all too short. But the man who has pictured such a situation a thousand times in his mind's eye will do the right thing instinctively, and, better still, his actions will not be complicated by the intervention of that most dangerous element—fear.

This is a great comfort for all who are not born Lindberghs. Any one can learn to fly well if he perseveres and exerts his will power, even if he lacks the instinctive sense to which we have already referred.

An old pilot who had occasion to note the success of this method with an untalented pupil once said to me:

“Now I know why, when his machine suddenly fails him and goes into a spin or a vertical dive, one man will see all his past life before him and trust to luck, while another turns off the benzine switch, cuts off his ignition or counteracts the failure of one control by judicious use of another while all the time his eye is searching the ground for the spot on which to make the best possible landing if the worst comes to the worst.”

On our third day of instruction the breeze freshens considerably, and the pupils rise higher and higher; one even reaches a height of thirty feet or so.

“It's funny,” another informs me, “that you don't notice the steps by which you learn to fly. Only yesterday my brain would have reeled at the thought of things which

to-day gradual practice has made seem quite natural to me.”

And now the air currents become very irregular, which is a good thing because their vagaries will give the pupils an excellent opportunity to learn how much the school plane can do by itself and when it is necessary for them to intervene.

Everyone is now accustomed to the new life, and it is delightful to witness the growth of comradeship amongst the pupils. The formation of groups, all of which are instructed on the same slope, has the great advantage of rousing a healthy spirit of emulation. Each group strives to achieve more than the others.

By the evening of this third day most of our pupils have taken a big step forward : some can fly nine hundred to twelve hundred feet over gently sloping ground when things go right.

Unluckily one man shows us at the last moment how not to do it. It is not often that anyone pulls the machine right over, though this is about the worst mistake that a flyer can make. The danger lies in the fact that the control lever of a plane which has been brought almost to a standstill by being pulled up too violently loses its motive power. A motor boat can only be steered while it is under way, and a motorless airplane, if pulled up too forcibly, is bound to lose speed after a short time, just as a ball which rolled uphill only goes a short distance, stands still for a fraction of a second and then rolls backwards. The flying machine does precisely the same thing.

Through carelessness a pupil had pulled the stick too hard. Flying sense says “Push,” but when a beginner finds himself hanging in mid air, his nerves scream out “Hold tight.” This pupil afterwards said : “I only wanted to hold on to something, and as there was nothing else at hand I held on to and so pulled the control lever.”

Bump ! There lay the plane ! while the flyer rolled over and over on the grass.

“What ought I to have done ?” he asked quite down-hearted.

“First of all you must not let the machine get into such a dangerous position. When you are flying close the ground,

you have not sufficient height to gain speed by pushing the stick over and diving, because you will crash before you can even out again."

Our dear old "Zögling" was so badly damaged that there could be no more thought of practice at the moment. Both main spars of one wing were broken, and the pupils sorrowfully dismantled the machine to convey it to the workshop. But before we departed we had a good opportunity to observe in the work of the other two groups that were practising on the same slope the other two great faults which, together with over-pulling, form the trinity of beginners' worst mistakes.

A "Zögling" started and flew quite smoothly at first, but all of a sudden its pilot, who till then had been calmly gazing ahead at the horizon, glanced down at the earth beneath him, and we saw at once how it affected his nerves. Twice, three times he pulled, then he pushed and crashed the machine against the ground. He pushed the stick so hard that the shock of a very rough landing burst his safety belt, and he flew almost farther without his machine than he had ever flown with it.

"I looked at the ground to see how my machine was flying," he told his teacher, who was surveying the result with a not exactly friendly expression.

"You know quite well that you were told to look steadily at the horizon," was the answer. "To fly by your distance from the ground is one of the very worst mistakes a beginner can make. It can be done in an emergency over very gently sloping ground; it is even possible under certain circumstances to fly down a slope at a level height of three feet above the earth if the gradient chances to correspond exactly to that of the angle of your flight. But it's all up with anyone who gets into the habit of doing this sort of thing if he suddenly finds himself over a steep drop, for he loses all possibility of controlling his position when the ground which he has been skimming seems to fall into an abyss. That's the end of his flying for a very long time.

"Moreover, every flyer is frightened when he looks down suddenly and realizes his own height for the first time. It was the shock of this which caused you to lose control just now."

The other error was just as instructive in a negative sense. Even before the pupil started we noticed how frequently he looked at his control lever. The teacher showed him its right position, but again and again he cast stolen glances at it. When taking off he was thrown a little out of his proper position by the slight jerk which accompanies the start, but he did not notice it. He was not looking at the horizon, he paid no attention to flying conditions, but kept staring at the lever in order to maintain it in what he took to be the correct position. So anxiously and attentively did he concentrate upon it that he never noticed how rapidly he was approaching the ground. There followed a cracking and splintering of wood—and the machine was temporarily out of action.

“You will never make a pilot if you keep on gazing at your stick,” the delinquent was told. “You must feel it while observing your machine’s position in the air and steer accordingly. If you want to pilot an engine-driven machine one day, you will have to learn that you cannot fly with your eyes on your stick, the correct position of which must vary in accordance with the number of your passengers, their positions in the machine, the weight of their luggage and various other circumstances. In a gliding machine it is just as bad to keep your eyes on the stick, because you will find it engrossing your attention so much that you have no time to look at anything else. Your stick geometry will cramp your style and prevent you from acquiring a proper air-sense.”

Those were our first accidents during this course, and nobody took them tragically. The velocity of our school machine does not exceed that of a skier going at full speed, while a fall on frozen snow with the long runners firmly buckled to the feet is decidedly severer than that of a glider on to grass or sandy ground—not to speak of the dangerous falls which motor cyclists experience every day. All our pupils know this, and therefore every accident is treated as a great joke by the victim’s comrades, and good humoured sarcastic criticisms pass from one group to another until an instructor orders silence.

“We have fooled enough,” he says, “now we will look

at the matter very seriously for once. We have seen what inborn flying ability you all have, and probably by now each one of you has a good idea of his own capacity. And now that you have recognized the problems which arise in the course of practical work we will consider them carefully. First we shall deal with the most important of all :

“ The correct flying position.”

“ How do we recognize the correct flying position ? ”

“ By the position of the plane with respect to the horizon,” says one. Another : “ By the regular rhythm of the humming of the wires in the wind.”

“ Right ! But that is not all ? ”

“ Also,” said one, “ I felt a difference in the strength of the draught on my face when I pulled or pushed more violently.”

“ You see then that there are many ways of judging whether your machine is flying at the right speed. We can make some use of nearly all our senses in flying. By them, too, we can distinguish between different methods.

“ First comes the eye ; it is the best measurer of dips. It can determine precisely whether the horizon divides the field of vision in the middle, and whether it wanders upwards or downwards or perhaps disappears altogether according to the extent which you pull or push the stick. This kind of observation is the easiest for beginners. You can see the horizon before you in just the same way whether you are fifteen feet or three thousand feet high. As long as you see the horizon you will never get nervous about your height. You have seen for yourselves the consequences of regulating your flight by your distance from the ground.

“ If you now take some object on the horizon as a fixed point to guide you, it will tell you whether you are dipping to one or the other side. If you want to fly straight ahead and your fixed point seems to move to the right or to the left, you must apply your lateral steering apparatus on the side in question until you have it quite straight before you again.”

“ But if we only look at the horizon, we shall never see if we are approaching the ground,” somebody objects.

“ That is not the case. Nature has given the human eye so wide an angle of vision that what you say is not accurate.

Even while you are watching the horizon intently, you will know immediately if you approach the ground. It will rise from below into your field of vision and so inform you that it is time to think of landing. But it would not be very serious if you failed to notice it. For our landings are quite different from those of the motor-flyer. Gliding and soaring planes have no high undercarriages, so that you do not need to pull the stick as hard as the pilots of engine-driven planes, who must bring wheels and tail skid to the ground at the same time and at their lowest speed. The motor-pilot has only one form of landing which corresponds to ours. He calls it a wheel-landing, by which he implies that he comes to the ground with his machine almost in its normal position. We always land in this way in gliding and soaring. Therefore it would be no great misfortune if you were simply to touch the ground in your normal flying position, though you would land more gently if you made some preparations.

“Long experience of training work tells us that this ‘fixed point’ method is the best for the normal beginner, though later you will learn its drawbacks. If you are flying in mountainous country or in fog, in clouds or by night, you often cannot see the horizon. He who knows no other method will then be at a loss unless he can call upon his sense of hearing for assistance.

“Every airplane is musical ; it varies its notes in accordance with the movements of the air. If you push the stick your plane moves more quickly and the humming or whistling in the bracing wires will increase. If you pull the stick the plane moves more slowly, and the music grows dim. As long as the wires are humming normally nothing can go wrong. When you begin to make a turn the wires have a different sound which is easy to distinguish from that of normal flight conditions. Also when you side-slip, you generally hear a different tone. Not everyone hears all these different notes so clearly, but even otherwise unmusical people notice at once if the sounds around them die away or cease. Then it is high time to push the stick over, and it is the best way of knowing that you have pulled too much.”

“ But what about a plane that is not braced with wires—one that has a cantilever wing or only struts ? ”

“ Even then there are sounds. On every plane there is something which vibrates to its motion. Even the tiny eddies that form in the cockpit or round the flyer’s head sing their tune, though on good machines the music is not so loud. But he who flies in them will already have had so much experience that he no longer needs the great orchestra of Aeolian harps—which every wire-braced flying machine is.

“ This acoustic method never fails us. You may fly by it through clouds, or through night and fog, where the eye can distinguish nothing, or in the mountains, where the view is limited. If you have practised it long enough, you can always hear how your plane is flying.

“ One drawback to this method is that each individual machine has a different tone. You must familiarize yourself with the music of each new plane you fly. There are variations according to whether the machine is speedy or slow, whether it has many wires or few or none. Often, too, the sense of hearing grows dull during a long flight. Then you distinguish only differences in tone but lose all power to comprehend their exact meaning. Where there are other noises which may easily overpower these, as for instance, the roar of an engine, your acoustic sense may let you down entirely.

“ And now for the sense of touch ! In soaring, owing to your open-air seat, you have an excellent opportunity to feel the currents on your face. Darkness and fog make no difference, but temperature and moisture do. We generally think a cold wind much stronger than a warm one, and a moist one differs from a dry one. But if rain or snow lashes our faces, all power of discrimination vanishes.”

“ Why don’t we just fly by the sense of balance which we have so strongly on the ground ? ” a pupil now asks.

“ Of that sense we can also make good use, but it is not nearly so useful in the air as on the ground ; it may even lead us astray, so that we form a deduction which is the exact opposite of the true one.

“ Often we feel the position of a plane quite clearly and

correctly by means of this sense. We notice that when we are climbing our legs are higher and our bodies slant backward. In the same way we also feel whether the machine's nose is dipping or whether we are 'hanging,' that is to say, whether the machine is in a slanting position. These things, of course, we can feel when lying on the ground or sitting in a chair.

" But this sense is only of use so long as it is not subjected to accelerated motion, as the physicists call it. By this I mean motion by which the velocity is constantly changing, or when the direction of the motion is altered, as is the case when we put the machine into a turn.

" You know that a cyclist must lean inwards when turning so as to avoid falling over outwards. In a motor-car, which cannot lean over, you are pressed against that side of the car which is to the outside of the curve. If you whirl round and round on a merry-go-round, you will be pressed against your seat in just the same way when it stops. A pendulum held in your hand would not point to the earth but slantingly outwards. If you shut your eyes, you could not say correctly, by your sense of equilibrium, which direction was upward and which was downward.

" This is the case with flying turns. Gravitation is not the only force acting upon us; it is accompanied by another force which acts outwards. This centrifugal force compels us, if we are to fly correctly, to put our machine into a turn. On this same force depends the success of the trick that you often see in a circus—the 'looping the loop' stunt. Centrifugal force continually presses the car, in which the daring artiste sits, against the rails; gravity appears to be suspended; it seems as though it was superseded by an attractive force that works outwards from the centre in all directions. Flying loops correspond to these circus loops; if you fly them correctly, you do not need your safety belt. Whatever your position may be, you will be pressed against your seat. If you shut your eyes, you will notice no difference from a straight flight, at least you will be unable to say whether you are flying up or down.

" If you are in a lift which is just beginning to rise, you feel yourself to be much heavier than you really are; if



44. STALLING: THE MOST DANGEROUS FAULT COMMITTED BY BEGINNERS
(Note the hurried flight of the starting crew, who realize that the machine is likely
to crash)

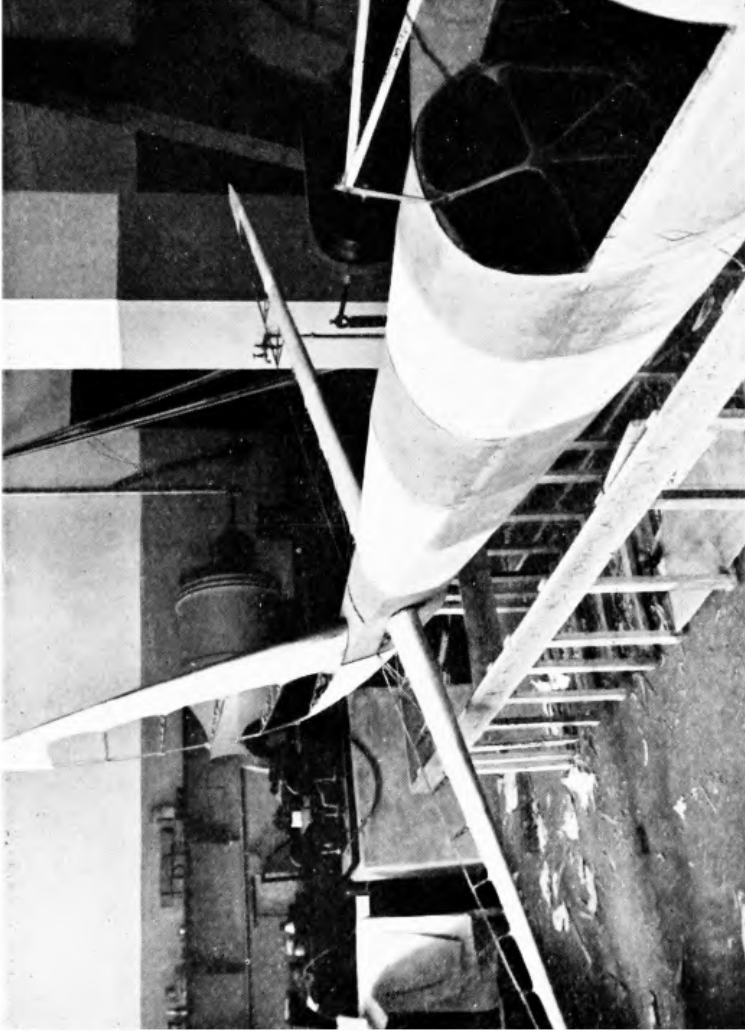

45. THE FUSELAGE OF THE MUNICH ACADEMIC FLYING GROUP'S
"KAKADU"

Facing page 163

it descends, you suddenly become lighter. In a flying machine these sensations are intensified, and so our sense of balance may lead us very much astray. You imagine yourself turning, whereas in reality you are flying straight ahead, or you turn without realizing it and still think the machine is flying as straight as an arrow. These are the mistakes that you will make if you rely entirely on your sense of balance, and by night or in a fog you will be continually at fault.

“ So your sense of balance, which is your best guide on the ground, may be the very worst one when you are moving through the air.”

“ But on the ground we find our way about in the dark by groping before us with our hands and feet. Is there any similar sense to aid us when we are flying ? ”

“ We can gain such help from the stick. The counter-pressure of the air on the stick always tells the experienced flyer whether he has pulled or pushed it too far, whether his machine is flying straight or going into a turn, and, above all, what is his exact position at the moment. Even if all other senses were to fail him, he could still tell what he ought to do by the pressure exercised upon the stick. He could feel at once if he had pulled it over too much, because the resistance to its manipulation would diminish considerably, and so he would realize that it was high time to push it back again.

“ Of course, these effects differ with different machines. In big, heavy motor-planes it is easier to feel your way by sensitive manipulation of the stick. In a light glider the steering forces are often very weak, which is the reason why pilots of heavy motor craft experience such difficulties when they first learn gliding.”

“ Must we learn all this if we want to fly ? ” asks someone.

“ Certainly, in all cases where the learner has to rely on head work instead of a natural air sense if he is to fly at all ; trained flyers can also refine and develop their air sense by means of such knowledge. It is a fact that everyone flies by intellect or sense ; often he does not know by which. One pilot relies mainly on his eyes, another on his ears ; this one pays greater attention to his sense of balance, that

one to the pressure on his stick. But no one really flies simply and solely by one method ; though most people rely mainly upon one and call others to assist them in case of need."

" But there are instruments which show us everything accurately. Why should we not make use of them when we are learning ? "

" Because if you do, you will never acquire the correct flying sense. Indeed, a most usual mistake made by young pilots is their blind dependence on the instruments in their machines which leads them to forget much of which they have taken so much trouble to learn. It is far more important to train yourself to fly first by the eye alone, then by the ear alone, then by your sense of balance and pressure on the stick. He who can use one or other of these senses is a flyer ; he who can make use of more than one at the same time is a good flyer ; he who has them all unconsciously is a very good pilot. But he only becomes a Master in the air who dominates it by means of all his senses equally, by a combination of instinct and intellect, which acts both consciously and unconsciously."

Such short explanatory conversations are always encouraged in our flying instruction. Owing to their close connection with the constant practice in which everything that is expounded can be tested practically the words of the teacher gain real significance in the minds of his pupils.

All the early period of instruction is for the pupil an intense conflict against obstacles of his own creation. Fear and nervousness suffice to make flying difficult, but we have had pupils who were free from both ; these simply seated themselves in a machine and flew.

" Fly ? Of course I can," said one of them once after his first " hop," " there's nothing remarkable in that ; it comes of itself, quite naturally." He passed all his tests in a shorter time than any other pupil because from the very beginning he had the flying sense and reacted to it.

Others must first grow used to the new element through practice. In their first flight they see and hear nothing, but after some practice one sense after the other is liberated.

At last they become expert steerers, and one morning

the instructor wakens them with : " To-day the wind is right for your first gliding test."

They are out of bed in no time !

The first test consists of a flight of thirty seconds duration along a suitable slope ; flying the usual school machine, the candidate must attain a height of at least one hundred and thirty feet above the landing place.

The first candidate starts well, but as soon as he is over the steeper slant of the slope, he begins to push sharply. He shoots down the incline at an unvarying height of about thirty feet, and cannot even his machine out until he is once more above level ground.

" What was wrong ? " ask the astonished pupils.

" He has not yet broken himself of flying by his distance above the ground," the instructor replies. " He flew parallel with the slope just now because he had no fixed point on the horizon to guide him."

The next does better. He starts calmly, with his fixed point kept constantly in view, and has no trouble with the little puffs of gentle breeze. Then comes something that upsets his calculations, for the height of the slope is sufficient to engender an upward air current, which he encounters soon after his start. It lifts him and renders him uneasy because he is unaware of its nature ; he thinks that he has caused his ascent by unconscious pulling at the stick and therefore pushes it over. He thus loses height so rapidly that he has to come down after a flight of twenty-five seconds.

" How can you know if you are pulling or if it is an upward current that lifts you ? " he asks.

" If you pull the stick, the tail drops and the machine's nose rises. The machine alters its position with regard to the horizon. But in an upward current the machine's position with regard to the horizon remains constant. You have your fixed point before you and climb without aid from the stick. This is the beginning of soaring, and you see now how important it is to keep the elevator as steady as possible and not to change your relative position to the fixed point."

At last one candidate does well. He glides along quite

calmly, manipulating his controls almost imperceptibly. A puff of wind deflects him a little to one side, but he quickly makes use of the opposite lateral control and the machine rights itself. Now a small gust lifts him, and now he drops towards the ground. You can plainly see him pulling. Twenty-eight seconds have passed, according to my stop watch. He is still in the air. Twenty-nine seconds. Will he manage it? He drifts lightly over the gently rising ground. Thirty, says the watch. But he contrives to fly across a little hollow. Thirty-one, thirty-two . . . thirty-five. Hurrah! Now he has landed smoothly. The first successful flight for the "A" badge has been flown!

And now, what excitement! Everyone congratulates him! Everyone wants to be the next to pass his test!

The successful candidate needed only nine practice flights to qualify for his "A" badge, and the beginners are delighted to see that one can really fly after only a few flights in glider.

The tests continue. As many mistakes are made as it is possible to make. One pushes too much; another pulls and drops down; yet another, who has been flying quite well, feels suddenly nervous when he is over the "high" slope.

Another starts well, but makes a left hand turn too slowly. He steers to the right, but the machine does not respond; in spite of his efforts, it continually pushes a bit round to the left.

"And yet I always managed the rudder quite correctly," he complained later.

"All the same you made a mistake which beginners often make," said the teacher. "Which of you followed his flight carefully? Did anyone notice what was wrong?"

Only one had observed the error. "The machine hung a bit to the left while he was trying to steer it in the other direction," said he.

"That is the explanation of your mistake. As long as a glider hangs to one side it is impossible to turn it in the other direction by means of your lateral controls. The machine must first lie on a perfectly even keel, which it can be made to do by the right use of the ailerons, then only

CLIMBING FLIGHT OF A SOARING PLANE
THE PILOT HOLDS THE
MACHINE ON AN EVEN
KEEL. AND IT CLIMBS
ONLY BY UPWIND PA-
RALLEL TO ITSELF.

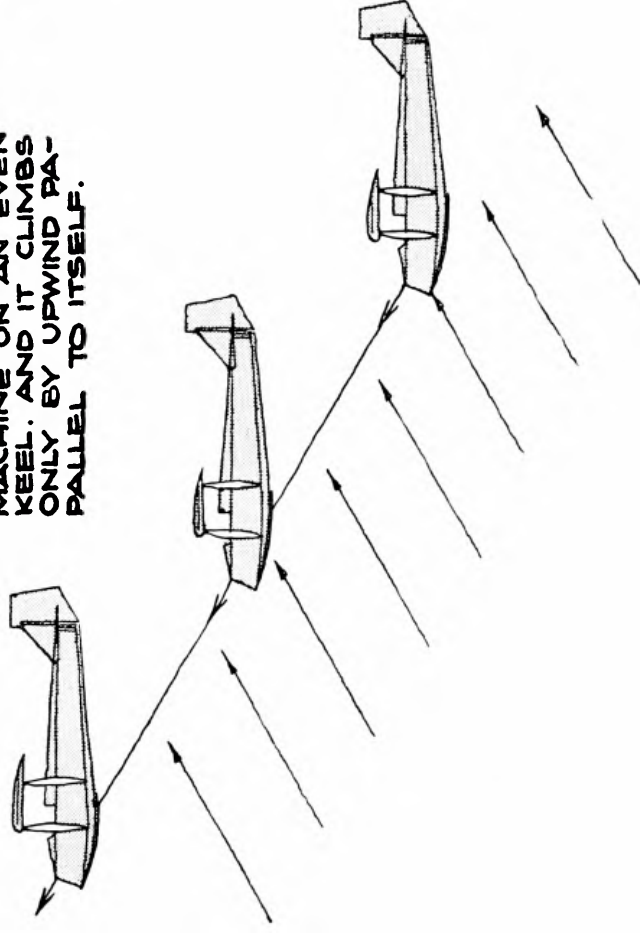

CLIMBING FLIGHT OF A MOTOR
PLANE. THE PILOT PULLS.

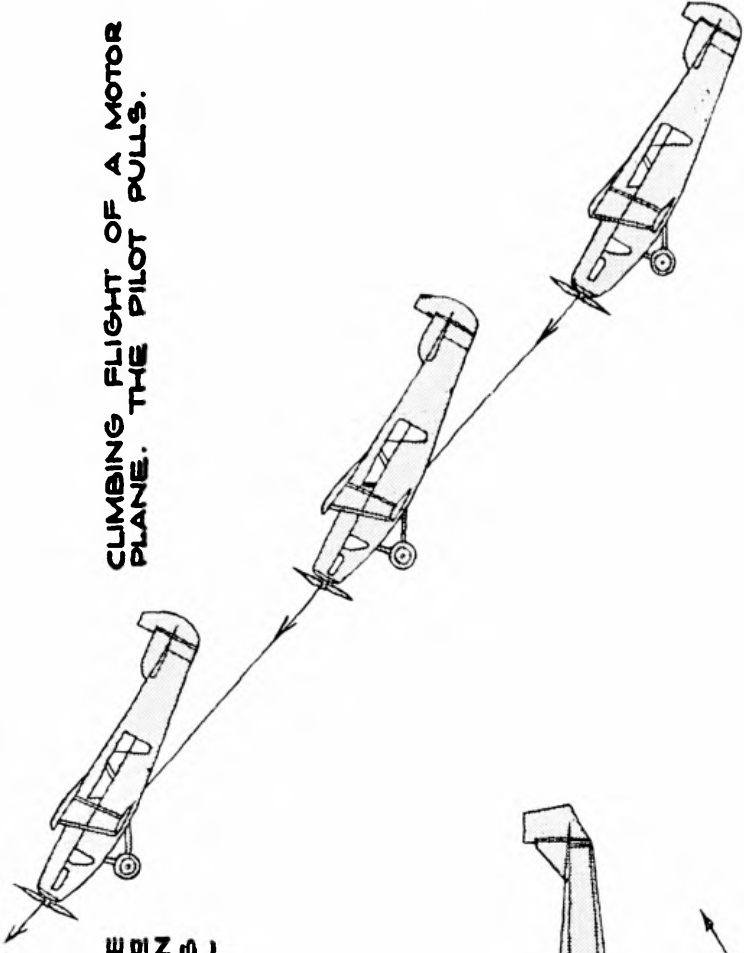

R. KRONFELD

Facing page 166

AN OBSTACLE IN THE COURSE OF THE FLIGHT

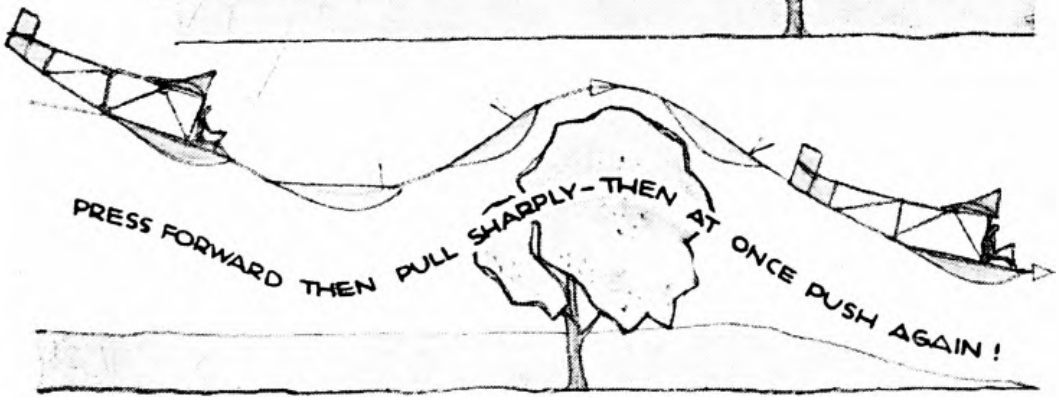
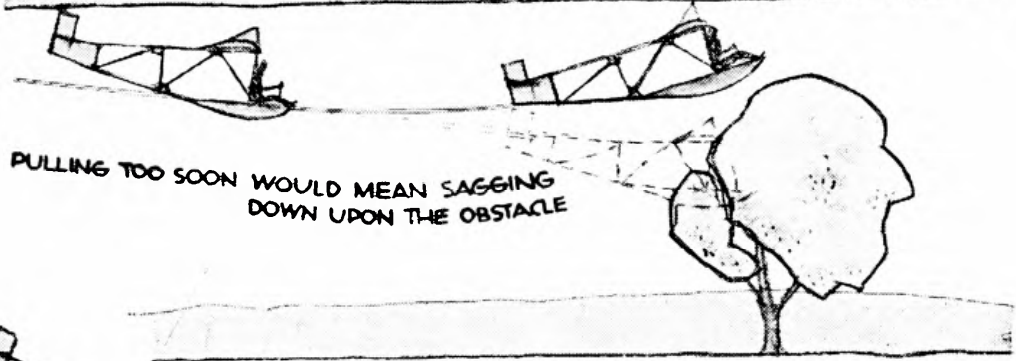
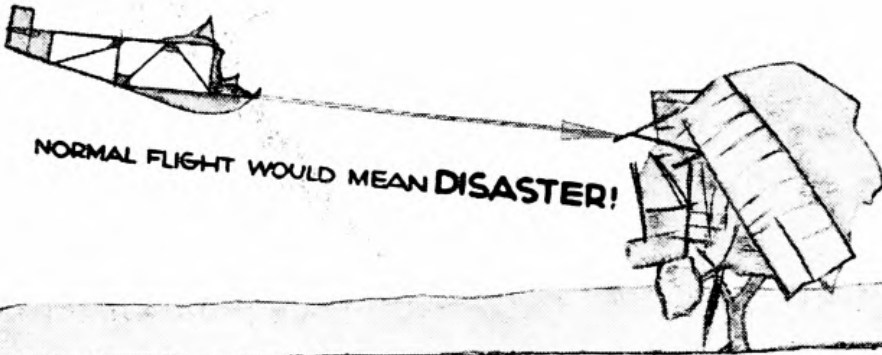

R. KRONFELD

can you use your lateral controls with any effect. When they do not produce the desired effect, you must turn your ailerons in the same direction.”

Thus the instructor must always render patient and tactful assistance to his pupils. Each one has a different grievance and wants some kind of special treatment. Already at this early stage the well-known types of flyers are beginning to develop ; there are the bold ones, the careful ones, the shy ones, the man who flies roughly and the one who hardly trusts himself to move the control lever. The advice that helps one is useless to another. Even the most expert teacher has never finished learning.

But progress is being made more rapidly in one case, more slowly in another ; in the end they all learn the beginnings of gliding.

Their senses which hitherto have been sorely oppressed are now liberated. They begin to see how the ground sinks beneath them, how the portion of earth which it is possible for them to see gradually extends as they rise, how a bird in front of them lets itself be carried higher by a gust just as they themselves do. They begin to hear how the wires sing, how the machine crackles, how the birds cry. They begin to feel how lightly they must steer and with what lightning speed and how strongly at certain moments, how the machine dances in every breath of air, and how every inequality of the ground throws up a different air current.

And so we begin to think that we are on the way to the conquest of a new world, which was formerly dead and empty for us. A new, living, manifold world—the Air!

ON THE WAY TO THE " B " TEST

IT does everyone good to gain the " A " badge, but this cannot be called a real test. It may rather be regarded as something in the nature of an incitement to further efforts.

The straight flights of the successful candidates take place over a gentle slope, the fall of which is hardly more pronounced than that of the taking-off ground. If you were to put a sandbag in the machine instead of a human being and fix the controls in neutral, it would easily make a flight of thirty seconds duration on a calm day without human intervention.

This says much for the flight powers of our beginners' machines, but no sandbag could do what the candidate for the " B " badge must now learn to do. Let us hear the words of the instructor on this point.

" We will now proceed to teach you curving flight, by which I mean that you must learn to change your course in the air deliberately. You will have to learn this gradually and by easy steps, and I want you to begin by starting off as quietly as if you were going to make one of the straight flights you are accustomed to. But when you feel you have the machine well under control, try to put it into a right-hand turn, and then, a bit after, have a shot at a left-hand turn."

The first pupil starts. His manipulation of the controls is somewhat hesitant, but you can see that he effects some slight change of direction. " I nearly lost all my bearings," he tells us afterwards. " I am so used to keeping my fixed point in sight, and when I turned, I lost it. I was so busy with the machine that I could not look where I was going. It was a lucky thing I was so near the ground ; otherwise the machine could have taken me just where it wanted. When you are making a number of turns, how can you be sure of reaching your destination ? "

" The best way is to make a definite plan before you start. That fixed point is a splendid help to beginners, and hitherto we have only let you undertake straight flights because we did not want you to fly over ground that would have been bad for landing on or go into unintentional turns. But now you must learn to move freely in the air, and if you are to have a proper control over your machine, you will have to learn to keep the whole horizon in view instead of merely one fixed point on it. To get your bearings correctly, choose some landmark on the ground. Fly to it ; then pick out another and try to reach that ; by practice you will eventually acquire such skill that you will be able to find your way about anywhere."

The pupil does not find it at all easy at first. As his turns—or rather, his efforts to turn—cause him to lose height, he has to take off over a more pronounced slope. He finds it quite uncomfortable to be flying some 150 feet above the ground.

When he has shown that he is sufficiently expert in the use of his steering-gear to carry out the exercises set him, he can begin to learn real turns.

The instructor tells him : " When you want to change your direction quickly, you have to use the rudder as well as the stick, but do not move it more than just enough to make the machine turn in the required direction."

The pupil who starts off after these words of advice generally takes them too seriously to heart. He wants to do a really good turn, but he is hardly off the ground before he kicks the rudder violently and pushes the stick hard over at the same time. The plane dips sharply as it turns, and next moment it strikes an attitude which would be a feat for any stunt pilot. But it is too much for our bold beginner ; we note his dismay by the sudden jerks of his steering gear, but luckily his Zögling is a patient bird ! He begins to side-slip, but luckily catches himself at the right moment before reaching the ground, and escapes with no worse consequences than a fright.

" That is a good example for you all. There is one rule to be observed in all turns made by gliders and soarers, and that is : keep your machine as level as possible. The

slighter your angle of bank is, the better you will turn. This is quite a different business from turning an engine-driven machine, which has to be banked over steeply for its turns on account of the greater weight and greater flying speed. I can easily make this clear to you by the example of vehicles driven on the ground. The heavier a motor-car is, and the greater its speed, the more a racing track must be banked at the turns in order to ensure safety at full speed. In the same way, the smaller the radius within which you turn, the more steep your angle of bank must be. The soaring plane is so light, its speed so low, that we can fly our turns perfectly with a surprisingly slight bank."

The performance of another pupil gives us still further food for thought. We saw clearly that he kept the machine perfectly steady till he had to apply his rudder. For whatever reason he used it—whether to dodge a gust or make a turn—he always moved his elevator as well, with the result that the plane made very remarkable leaps through the air.

"I don't know why, but I can't keep the elevator still when I have to use the rudder," he said.

"The reason is an anatomical one," I answered. "All the movements of the human limbs are more or less circular ones around a pivot. When you hold your arm as you do when grasping your control lever and then move your hand to the right or left, you will, quite unconsciously, describe an arc of a circle round your elbow, and thus you unconsciously move the elevator. To avoid this—here's something you can practise quite well in the machine on the ground—you must take particular care to move your hand backwards and forwards to the one side or the other in an exactly straight line when you push the stick sideways."

"How comes it that it is possible in the right type of machine to turn by use of the rudder only?"

"When you steer sideways, the plane begins to turn in the required direction. The result is that the wing which lies on the outside of the curve moves through the air more quickly than the one on the inside. The same principle applies to a squad of men drilling; when the order is

given to 'right wheel,' the outside man of the line must almost run, while the inmost hardly moves at all. Now the wing which moves more rapidly through the air increases its ascending power; it rises while the other does not, and so the plane assumes the correct angle of bank automatically."

Slowly but surely our pupils amend their errors. The matter which requires the most attention is the combination of ailerons and rudder in steering.

"Right foot forward, hand to the right! Left foot forward, hand to the left! You must practise that. Get clear in your mind what you have to do in every position; that is the chief rule for turns."

"What would be the result if rudder and ailerons were working against each other?" a pupil asks.

Let us suppose that you push the stick over to the left; your plane will want to turn in that direction. But you steer to the right with your rudder, you would naturally turn the machine to the right and make it dip in that direction. The two steering-gears neutralize each other, the exposed steering surfaces now act as brakes and speed steadily decreases until the plane comes to a standstill, just as it does when you overpull. If you do not soon realize your mistake, it will stand on its head and whirl down to the ground. This most unpleasant consequence of one of the worst of all flying errors is called a spin.

The next pupil tries to turn, but he does not move his machine round.

"As I was turning, I suddenly felt the air blowing in my face, both from in front and from the side, from the outer side. At the same time I was pressed outward against my seat. What was the reason?"

"By your mistake you have found out one way in which it is possible to ascertain whether you have made a good or a bad turn. A rush of wind from the side is always a sign of something wrong if you are supposed to be flying normally. It only occurs when the machine's forward movement through the air is not perfectly straight, but just the slightest bit askew. We call that 'shoving,' and it is bound to occur in a turn where the angle of bank is too slight. You see the same thing on a racing track that is not banked

high enough at the turns—the car skids outwards. This oblique movement is characterized by a side draught, while at the same time centrifugal force tends to push you away from your seat because you have not banked over with your plane in proportion to the force acting on you.

“ But the exact opposite can also occur ; you may feel a side wind from the inside and even be drawn inwards. This happens when your bank is too steep.

“ A rightly flown turn must be such that if you had a small pendulum hanging before you it would always be at a right angle to your planes, just as it would be in a straight flight. You may take it as a rule that whenever you feel a side-draught from the inside you must decrease the angle of your bank ; when the draught occurs on the outside, you must increase it.”

And so our schooling goes on, day by day. We do not fly too far, because we do not want the trouble of carrying the machine back for long distances up hills. It is greatly to our advantage that the wind often changes at this time, because all the pupils are thus able to practise gliding on different slopes of our mountain. They grow quite independent of the lie of the ground and no longer need to work their way from one fixed point to another.

Let us watch one of them start. He glances at the horizon. His position is correct. Now he looks round calmly to choose a point round which he will curve. He is no longer worried if he sees the ground below him, because he now listens for the regular humming of the bracing-wires ; if it diminished excessively, he would use his stick automatically. Now he reaches his turning-point. He thinks : “ Rudder, and stick over sideways a bit—not too much ! Now I feel all right. I am pressed against my seat just as I am when I fly straight, I feel the draught quite normally, from in front ; everything is as usual. I must go on turning steadily, now I am round, so push the controls back to their normal positions ! I am straight again and flying straight ahead. Now for the landing. Hallo ! there’s a bush in the way ! No ! I am well past it.” He now flies automatically—by his flying sense, as every good airman should.

The teacher is asked :—" What do you do when there is an obstacle in the course which you cannot dodge ? "

" You ought to be able to answer that question for yourself by now."

" I should simply jump the machine over the obstacle," says one.

" I should land before I reached it," another suggests.

" I should push the stick down and then pull up again," a third opines.

" Why would you do that ? " asks the instructor. " What is your reason ? "

A heated discussion follows. Rival theories are championed with lively voices.

" I tried just now to fly over a hedge, and found myself sitting on it."

" Yes, but it's no good to land before reaching your obstacle. I tried, but only succeeded in running right into it," says an opponent of this theory.

" Let us test all these suggestions," says the instructor, and demonstrates them himself. A flag in the ground represents the obstacle.

Shortly before reaching the obstacle, he pulls as suggested. Everyone watches attentively how the plane lifts ; it certainly seems as if it will rise over the imaginary obstacle, but by pulling his stick, the pilot has reduced speed, and suddenly the plane flops and comes down none too gently, right on top of the flag.

The instructor now tests the suggestion to push. But a plane is bound to gain speed if pressed when flying down a slope, and can scarcely be brought to the ground. A small hollow in front of the flag makes landing impossible. Bump ! This time the sharp swing round drags the flag out.

" Lucky it wasn't a rock," say the spectators.

" If you could do it properly, it wouldn't matter if it were a rock," says the instructor. " I will prove it to you by flying straight for that heap of stones down there."

The pupils watch this flight somewhat anxiously, but just before reaching the stones the instructor drops the nose of the plane and heads for them as if he intended to ram

them. He even drops to a level below the top of the hillock ; they imagine they can hear the crash. But then he pulls his stick lightly; and the plane, which has gained great speed by the dive, reacts beautifully, and bounds straight into the air. At the very moment of crossing the obstacle, he pushes quickly ; the plane drops before it is over-pulled and lands smoothly.

“ Fine ! Fine ! ” cry all those who have been following the demonstration intently. “ Like a man doing a high jump with a running start.”

“ Store up energy in the form of speed, and then use it when you need it,” remarks the instructor when he gets back to the slope.

“ To replace the reserve power which the pilot of a motor-plane possesses in his engine we must have height or speed reserve. They are, in a certain sense, equally valuable. By pushing, I can at any moment change my height into speed, while in an abnormally quick flight I can gain height by pulling at any moment. In both cases, this, of course, is only possible up to a certain degree. In all the difficult situations in which one may find oneself with a soarer it is well to have one or other of these reserves at your disposal. By pushing and accelerating speed, you can increase your steering capacity to such an extent that the machine will react to the slightest touch. Even if your impetus is not quite sufficient to carry you completely over the obstacle, you can make a fairly good finish by doing what I did just now. If you find that you have not enough way on, or that the hill or bush is too high for you to clear, it is best to land upon it. By pulling at the last moment, you utilize the machine's impetus to the full and make your line of flight accommodate itself to the shape of the hindrance, while you finish by landing at the lowest possible speed. On rocks you might have some sort of a crash, but you would not do much damage. And that, by the way, is exactly how high-performance soarers land uphill.

“ On the contrary it is quite wrong and very dangerous to try to land downhill ; it simply must not be attempted if there is any obstacle in front of you. If the slope of the ground is only a little more acute than the gliding angle of

your plane, you cannot reach the ground, for you would increase your speed and ultimately crash or ram the obstacle.

" It is just as bad to pull when you have not much way on. The best that can happen then is, as you saw just now, that you drop down on the obstacle. But you would be more likely to stall or even spin, and probably over just the worst sort of ground. But in any case you would have poor control over your steering and probably over-pull just at the moment when extremely good steering was necessary. You would be left hanging quite helpless in the air."

At this stage of instruction it is not advisable to let pupils make their first turn too soon after the start, as such a procedure might easily bring unpractised flyers into collision with the slope. It is, therefore, all the more important to train the pupils to fly accurately round the chosen point, as only thus can they learn to exploit their knowledge fully, so that later on it may serve them in emergencies and in their training for soaring.

Before the real Gliding Test or " B " test is flown, the difference in the ability possessed by individual pupils will have become more pronounced than in the earlier stages. Most candidates generally pass this test after from fifteen to thirty starts, according to their ability.

A little wind is of benefit to the candidates, but, as is the case with gliding generally, it is not absolutely necessary.

A flight of one minute and an S-curve are required. Each pupil must previously have demonstrated sufficient skill in flying to warrant that his success will not be a matter of chance.

Nearly all test flights are rendered more difficult by the fact that the nervousness of the candidates, against which they have been struggling during the whole period of their training, breaks out again in the form of " test fever."

They start from a point situated a good four hundred and eighty feet above the goal, a height which should easily enable them to remain the requisite time in the air, even in our school machines. The slope over which they start is steep at first, but gradually becomes less pronounced

and finally evens out into the level ground of the landing field.

When he has started the candidate finds himself suddenly high in the air, and this is the undoing of those who fly by their distance from the ground instead of a fixed point on the horizon. One of these sinners rushes onwards at crazy speed, keeping his line of flight parallel with the slope beneath him ; later he follows the contours of the ground and ultimately reaches the goal, but his flight has been performed at such a pace that its duration is less than a minute. Others cannot manage their turns, and a third type goes off the course altogether.

The candidate who pulls too much flies at a low speed and contrives to remain his full minute in the air, but fails to reach the goal within this allotted time. The flight with the best gliding angle is a speedier affair than that performed with the lowest descending speed ; consequently the pilot who wants to cover long distances must be continually pushing, while the man who desires to spin out his time in the air will pull as much as he can compatibly with safety. When the conditions of flight involve both pulling and pushing the pilot must be able to sense the exact flying speeds he requires.

Most men find this quite easy, and indeed many pass the " B " test only a few flights after the " A " test.

The start for the " B " test is an energetic affair, in which there are often five or six men on each side of the rope. But now the candidates know something of the nature of upward gusts, which they can distinguish from the air movements set up by their own steering. Generally all goes well until they reach the first turning point and have flown round it. Then the ground rises up to meet them as they fly onward to the second turning point, where they have to curve away in the opposite direction in order to gain the straight run-in to the finish. As soon as a candidate feels himself certain of completing the course, he generally pulls a bit in order to prolong his time in the air. And then . . . my kingdom for a perfect landing. . . .

It's everyone's ambition to fly a " B " flight which lasts not merely sixty seconds but ninety or one hundred.

Great is the rejoicing when the last pupil of a batch has passed his gliding test. And rightly so, for much has been attained.

We have learned to fly !

Many a man thus becomes a devotee of flying who could never have afforded to take an expensive course in a motor-flying school . . . likewise many a one who had only thought of enjoying some summer amusement. Pupils who have passed their gliding test have taken their seats in a light-motor aeroplane, and, after the few simple differences have been correctly explained to them, they have taken off and made perfect landings. Every student of gliding flight is more at home in the air than many who have learned to move in it in other ways.

When the gliding pupils shake hands as they say good-bye they know that they will see each other again somewhere in connection with flying. In motor-flight schools, at flying competitions, in every air port you will find men who began as gliders . . . equipped only with their pocket money from home and their enthusiasm.

Gliding is not merely a preparation for the new science of flight ; it is the most effective propaganda to popularize it with both young and old.

THE SOARING COURSE

‘**H**ITHERTO we were gliders, but now we have come to learn soaring,’ said one of the throng of young pupils who had joined our Advanced Course.

“What is the difference between gliding and soaring?”

“How do you manage to climb?” come the questions.

To let them see with their own eyes is the best answer. There is a good soaring wind; I climb into the “Prüfling,” our machine for more advanced pupils, which is as speedy and manœuvrable as a small motor-plane. The wind is blowing favourably at a right angle to the slope when I start. I soar backwards and forwards above the same slope from which the “B” tests were made. The pupils stand below, having been instructed to watch as closely as possible. I land at the top of the slope after a short flight of from ten minutes to a quarter of an hour.

“Now what especially did you notice?” asks the instructor.

“Chiefly that you do not lose height in soaring!”

“That is the most important factor; indeed soaring may be defined as flying without loss of, or with increase in height. No one is a soarer until he can maintain himself continuously at an elevation greater than that of his starting place and land somewhere at least as high as that starting place if the conformation of the land permits. Consequently it is no longer necessary, as in gliding, to keep our eyes fixed on or searching for the landing field far below us. Our whole attention can now be devoted to floating and climbing.”

“Why do you make so many turns on such a short length of slope?” asks one.

“A short slope compels you to do so. The soarer must be careful always to remain within the reach of a favourable upwind; hence the many turns and the continuous flight in an ‘S’-shaped course. The correct turn is the Alpha and Omega of successful soaring.”

“ Must we pull more in soaring than in gliding in order to keep ourselves aloft ? ”

“ Not necessarily. So far as the air is concerned, there is no difference between gliding and soaring. In both cases it is equally necessary to have good way on against the wind. Soaring is gliding in an upwind. We only notice the difference when we watch the flying from the ground. Imagine a small model of a glider gliding in a lift. As long as the lift remained motionless, the glider would sink towards its floor. But if the lift began to move upwards at a speed greater than that at which your model was falling, the latter would give you the appearance of rising. That is what happens when you soar. You glide downwards in an air current which is rising more rapidly than you are losing height by gliding. And this shows us that we should keep the machine in precisely the same position as in gliding, the only difference being that you must be more careful to fly correctly if you are to maintain your position. In gliding it doesn't matter in the least whether you push a little more or less to gain speed, and the same holds good for soaring, that is to say when the upwind is strong enough. But as a rule the conditions are such that the wind is just strong enough for correct soaring. Then you must manage to let your plane 'fly itself,' which means that you must not err through overpushing. Obviously overpulling is also just as bad an offence as in any other form of flying.

“ In gliding it is not advisable to make turns too close to the slope unless you handle your machine extraordinarily well. Therefore, as well as for reasons of safety, gliding practice is generally carried on at some distance away from the hillside. But for soaring the flyer must have learnt to master such difficulties ; the ability to control a machine easily and surely is a first condition of good soaring. All the mechanical movements of steering must be performed automatically, and indeed as long as the flyer is not exposed to any abnormal squalls, every action must be automatic because all our powers of observation are required for the upwind and for making our turns accurately at the proper points.”

“ Does the fuselage-plane which we use for soaring fly

very differently from the framework machine which we used for the 'A' and 'B' tests?"

"All steering rules are, of course, exactly the same. But the fuselage-planes are much more sensitive, and as they need stronger wind for flying, they are speedier. When you are used to these differences, you will prefer to fly in such planes, but people generally find it rather hard at first to accustom themselves to the new type of machine. You will soon realize that when we all practise with the 'Prüfling.'"

We set to work once more on the gentle slope. But this time our progress is quicker, for the material with which we have to deal has already been sifted, and all the pupils now here have shown flying talent. At first the sensitive machines are often over-steered, but soon everyone grows used to them.

One of the pupils pushes the machine too much. When asked why, he answers: "I am always afraid that I am over-pulling because the plane flies so easily, and I can only hear it whistling when I push."

"That is a mistake which is often made when you start to fly fuselage-planes, because they offer less resistance to the air and have no wires in which the wind can hum. All the sounds connected with such planes are softer, so that it is necessary to listen more attentively; this applies also to the feel of the wind on your face."

These difficulties in flying the new kind of plane are soon overcome. The real training for the "C" test, the Soaring Pilot Test, consists in the continuous flying of good "S" curves. For the "B" test two turns were required, but now the candidate must describe two complete turns upon a much shorter course or turn backwards and forwards more often upon a course of similar length as the former one. The main object of the flyer is to remain as long as possible upon a slope where the upwind is strongest. But the pupils soon find out that this depends more or less upon the wind; it is far easier to fly turns within a narrow radius against a strong wind than it is on calm days. The stronger the wind, the more our turns will be compressed and elongated; in such a way figures

of eight can be flown when the wind is sufficiently strong.

We soon begin to discover the capabilities of individuals, generally by watching how the different pupils succeed in flying along the edge of the slope and observing whether they can make good turns in places chosen for them beforehand. When soaring above a short slope, much of the available time and space must be occupied by changes of direction ; therefore at this stage of the training we devote special attention to the correct management of turns. Many a one who can easily keep his plane in the correct position when flying a straight course, begins to push too much as soon as he enters a turn.

So the work goes on day by day. Luckily the weather is sometimes quite calm, while at others a strong, gusty wind blows. It is good, too, for the pupils to obtain experience on slopes running in various directions.

Whenever possible, it is advisable to practise turns above a slope that can be used later to fly the " C " test. In every stretch of country there will be several such hillsides, and it is our first task to familiarize ourselves with all of them. It is important that all turns should be made precisely at the turning points. By this time the turn itself will not cause the pupils any great difficulties, but it is essential that they should feel as sure of themselves when turning as in a straight flight, and contrive to extract the utmost from their machines during their turns.

Some of them soon make their turns really well. Then they begin to pay special attention to the weather, and at last there comes one day a really good soaring wind.

One of the candidates makes a start. He climbs high at once and we can see how well he controls his machine in a straight flight ; his turns, too, are correct. And yet, in the course of his flight, he drifts slowly but continually away from the hillside without seeming to notice it. The farther he drifts from the slope, the weaker is the upwind, until at last his machine begins to sink, so that he cannot attain flight of five minutes' duration above starting point that the test requires. We watch how he endeavours to save the situation by sharp pulling, but in vain ! The plane drops and drops !

The poor pilot returns with a sad face. "The upwind grew lighter; it was impossible to stay up any longer!" he vows.

"It was not the upwind's fault, but your own. To soar properly you must be able to maintain yourself above the upper edge of the slope. Parallel with that and a little outside the real fall of the slope, there is a streak of the strongest upwind, and you must try to keep within reach of it. The figure of eights that we fly are nothing but elongated, compressed 'S' curves within the field of action of this upwind."

"But what must I do when I can't manage to turn sufficiently to get back to the hill?" asks the pupil.

"In that case you must try to hug the slope more closely than usual before you enter the turn. It doesn't matter in the least if you get a little out of the strong upwind field provided that you are flying in the direction of the slope, for in that case you will find yourself directly in the strong rising air current as soon as you turn against the wind. The advantage of this is that your flying speed is slowest when you are flying against the wind, and so you can maintain your position for a longer time in the strong upward current. So always remember to hug the slope before beginning a turn!"

The next candidate does well on the whole, but we see that he continually makes faulty turns. At one time he pulls too much and slips till he nearly touches the slope, at another he pushes too much so that the plane cants inward too slightly and cannot get round properly.

"What must I do," he asks, "to keep the machine in the right position in a turn?"

"It will help you to study and use all the flight conditions in the same way that you did in straight flying. Instead of a fixed point take the whole horizon line and be sure that it glides along before your eyes quite smoothly and regularly. Generally it is easier to get round if you pull very gently when you are in the turn, because the rise slows you down a bit, and the wind then carries you again towards the slope. But, above all, do not think of turning as something out of the extraordinary. Fly calmly along the slope, get a little

THE ORDINARY CURVE NECESSARY FOR THE "B" TEST MAY BE CHANGED BY THE INFLUENCE OF THE WIND INTO A CORRECT "S" CURVE SUCH AS SOARERS USE WHEN TACKING ABOVE A SLOPE. (HILLSIDE)

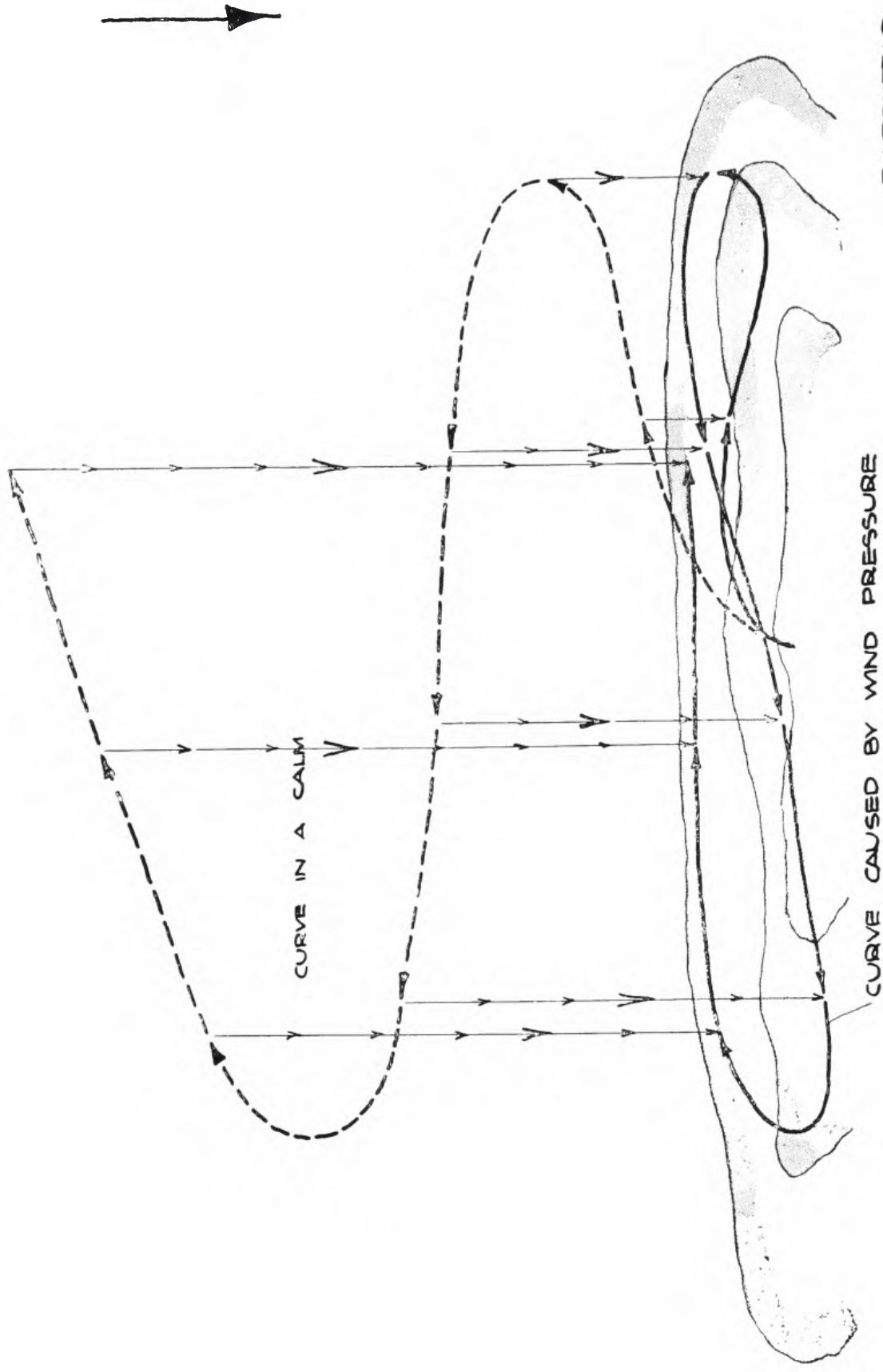

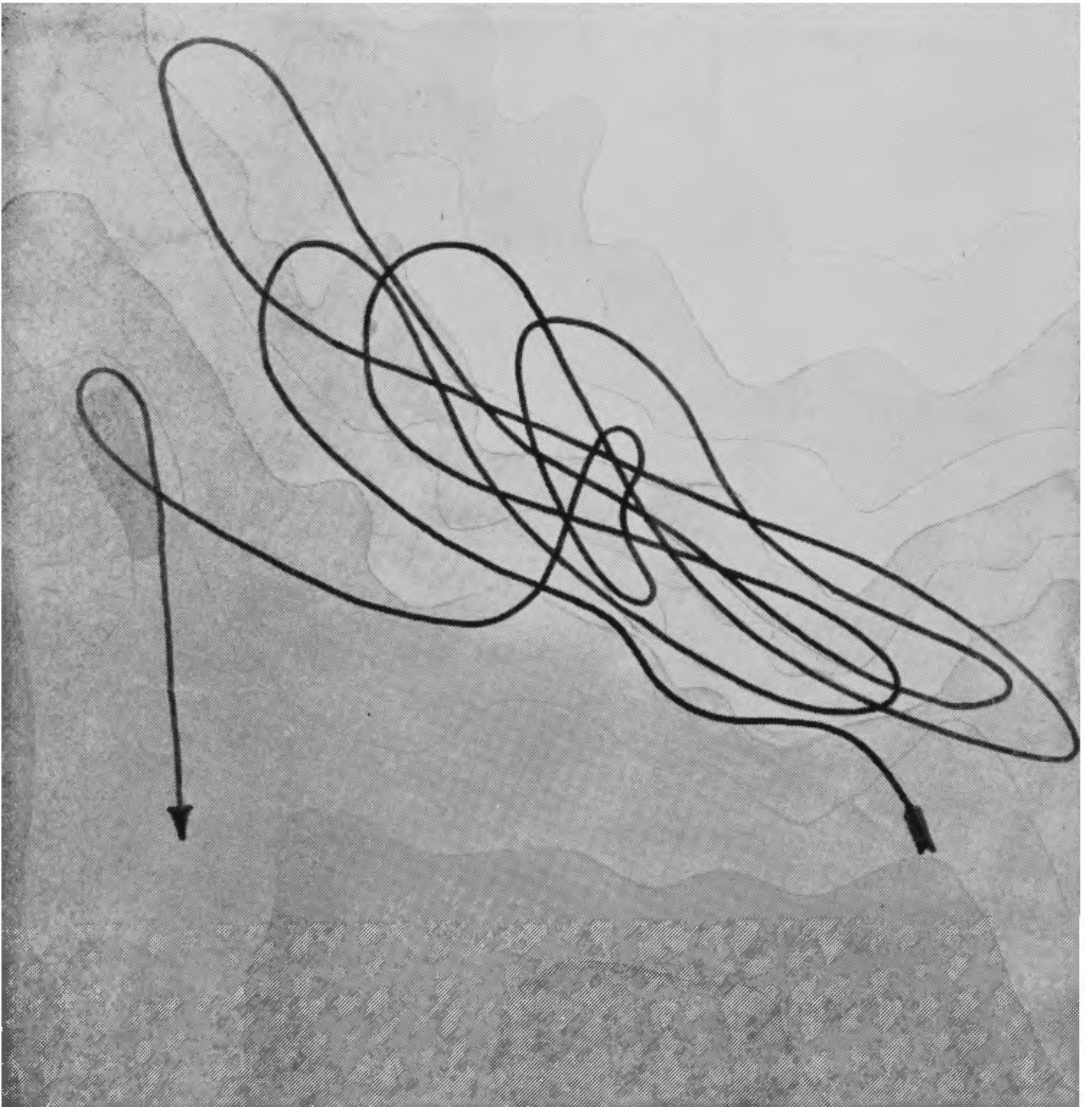

49. NORMAL SOARING FLIGHT ON SLOPE ("C" TEST)
PLANE TACKS ABOVE THE STEEPEST SLOPE

Facing page 183

nearer to it before beginning your turn, then steer with ailerons and rudder in the same direction, fly steadily onward, and wait patiently till the machine carries you round ! ”

The wind has changed ; we move to another slope, and once more I demonstrate. When I land, a pupil asks : “ Why do you sometimes begin your turn at a certain spot, while at others you start it much sooner, almost in the middle of the slope ? ”

“ You must all have noticed that a good machine has a tendency to luff, that is, to turn of itself towards strong gusts of wind. When you are flying on a slope, you continually feel the gusts that play about it turning the plane into the wind and away from the slope as they rise. Now every gust brings with it a stronger upwind, and it would be foolish and useless to try to force the plane out of this upward current. The machine itself shows us quite plainly where the most favourable upwinds lie, though when the gusts are too weak we ignore such hints. But if the tendency to turn is very strong, then it is advisable to take advantage of the gusts and carry out the curve which has already been initiated by the luffing. And this is the way to maintain ourselves the longest possible time in a strong upwind.”

Once more the word of command rings out. “ Pull out ! . . . Run ! . . . Let go ! ” But this time something goes wrong at the very beginning. As soon as the plane reaches the upwind field and begins to climb, we see that the pilot is nervous. He presses very suddenly. The upward current lifts him again ; then comes an upward gust which could enable him to climb, but he pushes once more, and is soon compelled to land.

“ I was always afraid of over-pulling when I climbed,” says the pupil later.

“ It is most important that you should learn to discriminate between the short climbs when we pull and those which are necessary for soaring. Climbing by pulling is impossible unless some outside force helps the machine to rise. We only climb as long as the machine is under way, but it soon comes to a standstill. Only in motor-flying where

a powerful engine supplies continuous force, can we climb by pulling the machine high. The correct climb in soaring is that by which the plane rises parallel to itself. The longitudinal axis of the machine lies always in the position for normal flying ; i.e., horizontally ; moreover, when we are climbing the horizon will always lie at the same height before us. When this is the case we may rise in the upwind by spurts of from twenty to thirty yards or more at once without danger of over-pulling. But sometimes in very violent squalls the machine gains great speed, in which case we may pull a bit and so transform the kinetic force into height."

At last there comes a candidate whose work is perfect. He starts, makes good use of his starting impetus and flies correctly. We see how the plane begins to climb at once, how the turns are carried out, calmly and methodically, in the right places. As in all exhibitions of good soaring, we gain the impression that this flight might go on for ever. And the plane rises steadily all the time. By the movements of the steering surfaces we see how gusty it must be immediately above the slope. That is, of course, only natural, for every inequality of the ground throws up gusts. The higher the plane climbs, the steadier it becomes until at last it reaches the perfectly still stratum of air in which it can float onward quite easily. We see plainly that this pilot possesses fine flying or air sense. He keeps his machine constantly in the best upwinds ; directly after starting he was somewhat in front of the slope, but when he had climbed enough he flew over its upper edge and now, having risen very high, he follows the course of the upwind, and the higher he climbs, the farther he returns behind the slope.

So he easily flies his five minutes and passes his Soaring Pilot's Examination. His comrades below shout up to him delightedly, and he waves back to them from above. He has understood, but he still continues to soar until, with a flying time of from ten to fifteen minutes his " C " test has become a brilliant affair.

But landing causes him some difficulty ; never before had he landed high up at the starting place. He has to

make several attempts, and once he narrowly escapes getting into the downwind. But at last he succeeds, and the first "C" test of this course has been flown.

"That was a wonderful flight," said the young pilot later. "But I had to rack my brains to find out how to land. I had entirely miscalculated the speed of the machine."

"That happens very often," says the teacher. "But you can easily avoid such mistakes once you have fixed clearly in your mind the proportionate velocities of a plane when flying with and against the wind. The best soaring wind is that in which the plane comes almost to a standstill if lightly pulled against it. With our 'Prüfling,' this occurs when the wind is blowing at a speed of thirty miles an hour. When we are flying into the wind, from the point of view of a man on the ground we have little or no flying speed. If we must turn in order to prepare to land, our speed increases in a moment to sixty miles an hour, that is to say, the machine's velocity is multiplied by that of the wind. If you do not then turn back into the wind at the right moment, you are likely to over-run a fixed landing place badly. It is therefore best never to turn directly out of the wind if you want to circle round to reach your landing place; bank the machine a bit and let the wind drive you sideways, so that by tacking into it more or less vigorously you may manœuvre your way slowly to the landing-place. But a good soarer ought to be able to land with the wind behind him without being inconvenienced by its velocity. In such cases, however, he must take great care to fly exactly in its direction, otherwise there is a risk that its velocity may tear the skid off the plane when it touches the ground."

By this time the breeze has dropped considerably, and we have a good opportunity to practise landing with the wind.

"Start, gain a little height on the slope, and then turn out of the wind, taking care not to drop below the edge, because you are still so inexperienced that any attempt to land uphill, as expert flyers do, would be very dangerous for you. You must still land high up on the

summit or even on almost level ground. You land as usual, but be sure that you push the stick the moment the plane comes to rest after landing, otherwise the wind may easily turn it over."

The first part of this programme is carried out perfectly, and everything goes well until the actual landing takes place. The pilot catches up the machine slightly, and now it touches the ground. But we can all see that the flyer is no longer following the instructions which have just been given. Probably he undervalued their importance, at any rate the plane's elevator remains after landing in the same position that he placed it when catching up the machine before landing.

"Now we shall see it turn turtle," says the teacher.

And he is right! The wind has pushed its way in under the elevator, and the tail rises gradually. Now the pupil pushes, but too late! The wind turns the machine over on to its back.

The "Wrecker" crawls up to us dejectedly.

"The rudder is bent, and several ribs are injured," he announces in sad tones.

"The best thing for you to do is to mend the machine yourself in the workshop," says the instructor. "One thing we must all impress upon our minds again and again, so that we are sure not to forget it in moments of emergency, and that is: after landing with the wind, push the stick over sharply. The best thing is to do it while the machine is still sliding along the ground."

As soon as the first Soaring Flight Test has been passed, a spell is broken. The following days bring favourable winds, and a long series of excellent flights. One after the other passes his test. And a most pleasant ending to the course is—time and weather permitting—to let each pupil fly for an hour.

There is not one of them who does not climb out of the machine laughing with joy after such a flight. Soaring is the reward for the trouble of learning to glide. There is only one thing which surpasses it—competitive flying with high-grade machines.

TURNING CURVE IN A STRONG WIND

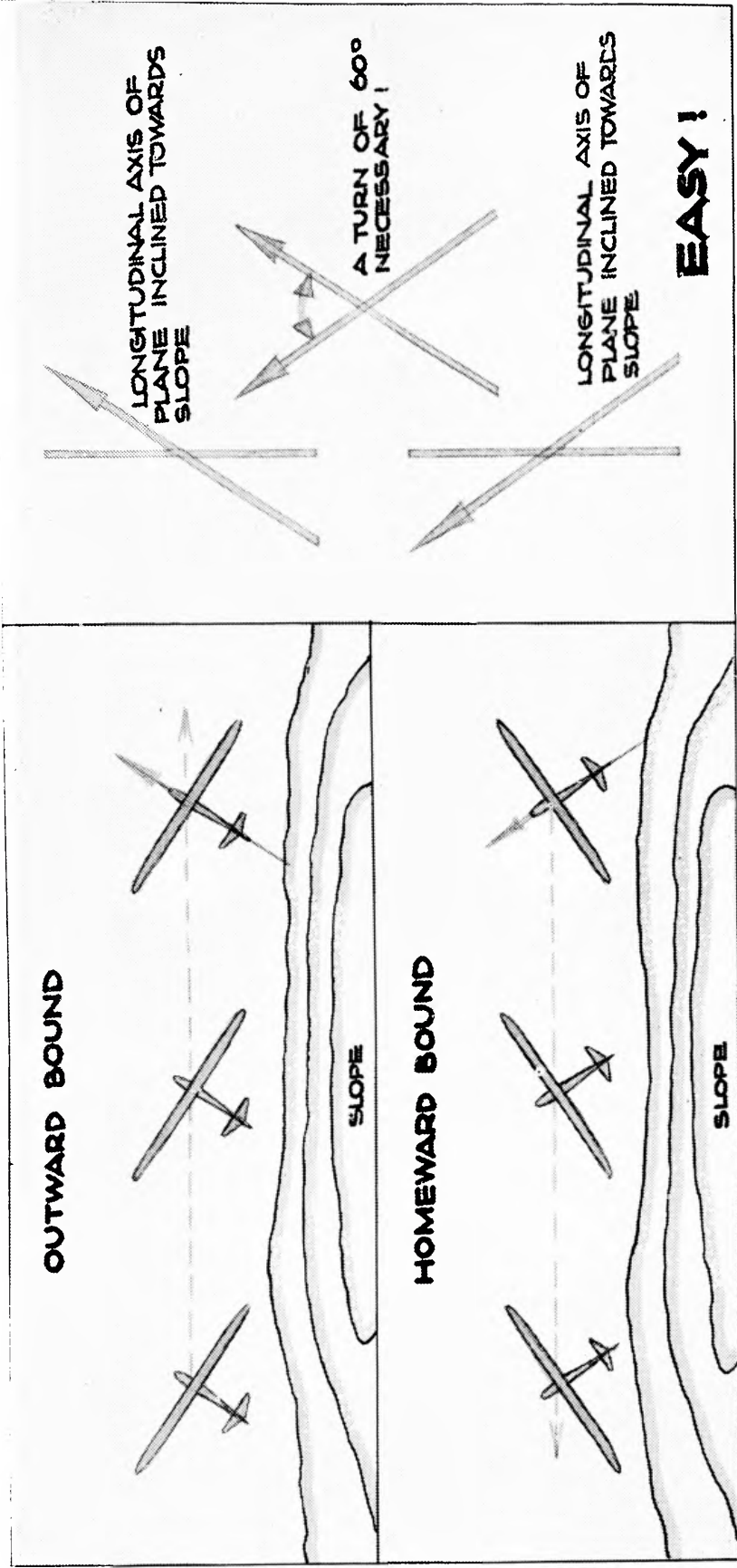

R. KRONFELD

Facing page 186

TURNING CURVE IN A CALM

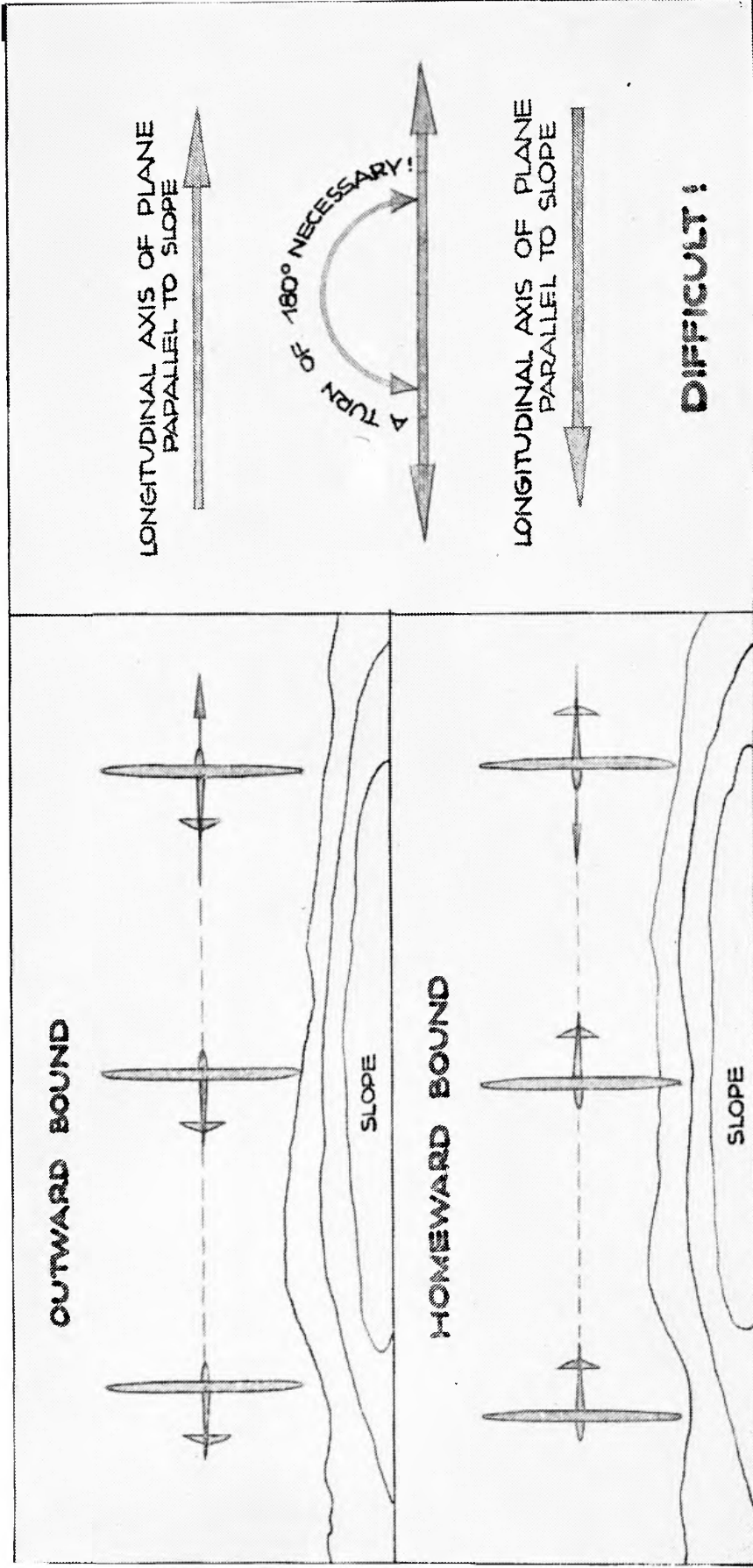

R KRONFELD

HIGH PERFORMANCE FLIGHTS

THE flights made by Lilienthal and the brothers Wright were remarkable achievements. Measured by standards of skill, they were as remarkable as those performed by the best of the modern flyers, perhaps even more so.

If we are to judge merit by a comparison between the achievements of persons we call great and those of their contemporaries, the results obtained by those men were as outstanding, relatively speaking, as any of the record flights of to-day. Modern achievements are greater only in their standards of values, though these are naturally the standards by which the average man judges them.

Nevertheless there is one important difference between those early days and to-day. Eliminating the question of technique for the moment and considering only the actual flights, we may say that those pioneers owed the distinction they won solely to the sensitive, skilled hands with which they manipulated their machines. The modern flyer has to use his head as well as his hands.

As far as pure flying is concerned, I may venture to say that Martens possessed the standard of efficiency we demand from a modern expert pilot when he struggled through his first flight of an hour's duration in 1922. The only factor that makes modern flying more difficult is the increase in the dimensions of the machines. What we mainly require from the modern super-plane is a good gliding angle which will enable us to glide the greatest possible distance from an elevation, combined with a low sinking speed, so that we can remain aloft in limited aerial fields, even when the upward movements of the air are only slight. Finally, we demand a great range of speed—in order that we can fly slowly without stalling and quickly without creating a bad gliding angle.

But these excellent qualities, which can be developed to a much higher degree in gliders and soarers than in power-driven planes, are dearly bought, as we can see at once if we watch a good flyer using one of our super-planes for the first time. With an expert crew at the rope the start presents no difficulty, and a straight flight seems easy enough. But the otherwise obedient bird appears to boggle at rounding a corner ; it is difficult to put her properly into a turn and not exactly easy to get her out of it again. There are also difficulties in landing ; the machine glides on long after the flyer feels that he ought to have reached the ground. On a small landing-place it is really difficult to get down at all, and the slightest inattention will cause one wing to graze the ground, with the result that the plane swings round violently.

We see that the qualities which are so good in some ways give us difficult problems to solve in other directions. Large machines are naturally heavier than small ones, though when they are in the air this greater weight will be offset by the larger bearing surfaces. The starting operations also need greater exertions and more concentrated attention. The simple rubber rope no longer suffices ; two or even three such ropes are needed. Six to ten men pull on each side, while five or six sturdy young fellows must be able to provide the necessary resistance by hanging on to the tail. Usually they seat themselves on the ground, with their feet firmly planted in holes that have been dug beforehand. Successful experiments have also been made with posts to which the machine can be attached ; in such cases the pilot releases the connection at the last moment by an automatic device.

The pilot's greatest problem is that of deriving the greatest benefit from the energies created by the starting rope. The sharp jolt given by this method of starting requires him to press himself firmly against the back of his seat. A common mistake is to climb too rapidly at the moment of starting. In such cases the rope has to be flung off too abruptly, and the man who will make the best use of the power germinated by his start should push his stick slightly as the rope is released and fly away only a little

distance above the heads of his starting crew. The rope thus remains in contact with the machine until the last moment and gives it the benefit of all its impetus. By pulling the stick, the speed obtained in this fashion can be transmuted into height, but care must be taken to push it back again the moment normal flying speed is obtained in order to eliminate the danger of stalling.

There is an absence of noise about the types of machines that are aerodynamically perfect. Even in swift flights hardly any increase of sound is noticeable, while the decrease occasioned by a stall is not very great. Much practice is needed to accustom the pilot to this peculiarity. Moreover, in these machines his seat is placed in front of the wings, so that he cannot as easily observe his position in space as in a school glider.

Typical of the large-winged machines, with their enormous span, is their lack of reaction to the aileron. Steering by manipulation of the ailerons is a slower business than it is with machines of lesser span. In straight flights this is not so noticeable, because although the mighty wings sometimes seem to resist the pilot's manipulations, they are, on the other hand, hardly affected by gusts that try to capsize them; their stability is therefore excellent. But if the pilot goes into a steeply banked turn by vigorous manipulation of ailerons and rudder, the machine will seem bent on staying in it. Consequently he should apply the opposite motions some moments before the turn is completed if he is to come out of it satisfactorily.

The flyer who desires to perform great soaring feats must be miserly about every inch of height and learn to take full advantage of even the slightest sources of power. In other words, we must fly as economically as we can.

We must endeavour to move our steering surfaces as slightly as is compatible because large surfaces that project into the air create resistance and consume energy. As such extreme manipulations of the steering gear are absolutely essential for steeply banked turns, the latter should be avoided whenever possible, and if you watch expert soarers in machines of large span, you will be

astonished to see how low are the angles of their turns.

There is another explanation for this. The changes of direction needed on a slope are not really so great as they may appear, while the position of the plane with regard to the direction of the wind and slope is determined by the parallelogram of speed produced by the combination of its own speed with that of the wind, plus the direction of the goal.

If you desire to steer a boat across a rapid stream, you do not make directly for your objective ; the stronger the current, the more sharply you have to keep your boat's nose against it. The same applies to the soaring machine, the longitudinal axis of which lies always at more or less of an angle to the direction of its course against the wind. If you want to take a boat across a stream and back again, you do not turn it completely round when you start your return journey, but merely put it at the same angle to the current as you found necessary on the outward trip, but, of course, in the opposite direction. When, therefore, we want to fly to a point opposite one we have reached, we do not need to put the machine into a complete rightabout turn. It will suffice to change our direction to a degree that diminishes in proportion as the velocity of the wind increases. To effect this reverse of direction, therefore, only slight motions of the steering gear are needed to put the machine into a slight turn. And thus it sometimes happens that a pilot who is flying quite correctly gives the impression that he is putting his machine into the tabooed skidding turn.

He who drives quickly has difficulty in pulling up. This is true on the ground, and just as true in the air. He who glides well finds difficulty in landing. He arrives somewhere after a wonderful exploit, having perhaps broken a world record and is happy to be coming down again. From afar he had chosen for his landing a clearing in a wood or a field between two groups of houses. He clears his last obstacle at a low height and arrives over the landing place. But it draws no nearer to him ; he pushes the stick but only gains speed and still remains too high up. Now he tries a side-slip, but it does not bring him very far

down, and the obstructions on the other side of the landing place loom unpleasantly nearer until suddenly he is right up against them. He realizes that he has miscalculated, makes one despairing turn and may indeed thank his stars if it succeeds in obviating the necessity for someone to pick up the fragments of his machine and carry them home in a handkerchief.

In soaring flights the question "How shall I get down?" is often more difficult to answer than "How shall I get up?"

And yet in principle the means that help us are the same, although we put them to opposite uses. An upward current helps us to climb: a downward one will help us to land, if we can use it properly. If we make a flat turn to gain height, a comparatively steep one will help us to lose it. If we can rise by means of steady flight with the least possible steering movement, we can drop by sharp and alternating manipulations of ailerons and rudder.

It is essential to approach a small landing place sideways, with the machine banked, so that you can insinuate yourself into the limited space by means of a series of "S"-curves, which will be helped by the other factors we have already discussed.

One other matter calls for the greatest care in landing. We must avoid touching the ground or anything that projects from it with a tip of the great wing that is poised so close above it. When landing on level ground, such as a meadow or a stubble field, it will suffice to put the wings in a perfectly horizontal position. Then, when the machine is nearly at a standstill, they will gradually subside to the ground on one side.

Landings in hilly country and on steep slopes are more difficult. In both these cases it is necessary to abandon the horizontal position. We must often lift one wing-tip over a hillock, stone or bush, taking great care at the same time that the other tip, which naturally must sink, does not touch the ground. Moreover, the horizontal position is unsuitable for a steep hillside landing because it is almost certain to lead to a catching of the wing on the side which is towards the hill. At the last moment the

ailerons must be employed to give the wings an angle that will enable them to lie parallel to the slope.

The veto upon downhill landings which is so frequently stressed in the period of early training gains importance as the gliding angles improve. With high efficiency planes it is impossible to land when flying downhill, but their use frequently involves uphill landings with the wind behind the machine if the pilot is to land at a high starting place after a flight that has been cut short by loss of wind. In such cases you sometimes dash towards the slope at sixty miles an hour, and the steeper it is the more sharply you must push before reaching it. It looks as if you are trying to ram it, and you must therefore keep all your self-preservation instincts under the severest control until the last moment. Only when the onlooker imagines he can already hear the crash may you pull sharply on your elevator, so that your line of flight assumes the same angle as that of the slope. By means of the gentlest pushing and pulling you accommodate yourself to the gradient of the slope and land well under the most difficult circumstances.

Although such landings are generally brought off well, the pilot needs very practical powers of self control. Often two landing possibilities present themselves, one of which is safe, on level ground, straight into the wind, but at a spot where no one will see it, while the other is uphill, daring and right in the midst of a cheering crowd. The conscientious pilot will always choose the safe landing, unless some very important factor drives him to decide against it.

All this is part of flying knowledge and skill. The pilot who acquires the feeling that he can handle his machine well and make his turns in the correct places and is also confident that he can land safely, will certainly soon feel a desire to put his knowledge and skill to some practical test. In soaring the simplest way to do this is to make an endurance flight.

For such a flight a good machine, capable of holding its own in a region of upward currents, is important ; the other two factors are a steady wind and a steady pilot ! The better and steadier the conditions are, the easier is the task for

both plane and pilot. In a strong and steady wind, good flights of great length have even been made with school machines. The qualities required for endurance flights are purely sporting ones.

All over the world there are regions (especially in the neighbourhood of coasts) where regular and steady winds, little troubled by gusts, blow from morning till night. These are the best flying districts. In places where the meteorological conditions are not so favourable, it is advisable to consult a weather chart, which will tell you with a fair degree of certainty if you can find the needful strength and steadiness of direction in the winds of a given district.

The simpler the slope, the more extensive and the easier it is to survey as a whole, the better is it for your purpose. When a short slope necessitates constant turns, the pilot tires more quickly than over a long one where he can float along tranquilly for miles.

Equally important is a wide wind area which does not force us to make the radius of our curves all too narrow. Moreover, the quality of the landing ground spread out beneath us may be of greater importance for the success of our flight than might at first be imagined.

If it is possible to land at any moment, it is also possible to remain above the slope till the last moment, even though the wind should drop. Even when you have descended to within a few feet of the ground, it is often possible to work yourself up again if the wind freshens slightly. But if the opportunities for landing are bad—say a small, distant field—then you dare not wait for the last moment. You must leave the slope in time and pick out your landing place.

When in the air it is advisable to gain an accurate impression of the formations of adjacent mountain groups or ranges, as well as to ascertain where you may expect to find the strongest upward currents. Then you can take advantage of such spots by heading for them if the wind drops. Smoke from a fire on the ground will show us the wind's direction, which, however, is only of great importance when it changes. It is often customary to trace figures on the sand or display them on boards to tell the pilot the

wind's velocity and let him know whether it is likely to drop or freshen.

If you contemplate prolonging a flight into the night, it is essential to take careful note of the turning points beforehand. Then they need not be marked by glaring lights.

During the early part of such a flight we must try to fly with the least possible expenditure of energy. In an area where the upwind is good, it does not matter if the plane hangs a little or is pushed somewhat too much. The more the machine flies of itself, the less energy do we require to use, and so we may save up our strength for a falling wind, when it becomes of the utmost importance to extract all we can out of the plane.

If we choose our slope carefully and hit upon one that offers a few difficulties, the pilot will not be called on for great mental efforts. Success in endurance flying depends largely upon skill and staying power.

Systematic training of the will and bodily strength is of primary importance. Every pilot has his own way of getting the last ounce out of himself, which is well for him because it is extremely difficult to force the mind to concentrate on the details of a safe landing after a long flight, and still more difficult to overcome the dead point in one's own energy. One man may help himself by muttering words of encouragement, another goes into a dangerously banked turn to waken himself up, while a third shouts the latest popular song at the top of his voice. But these are the personal secrets of our pilots! No general rule can be given here!

We cannot ever dispense with endurance flights, as they are the basis of all skilled flying, but we must not forget that they are only a basis. When the flyer has advanced beyond this stage, he will desire to try long-distance flights.

The very best practice for this is to fly to a distant goal and return to the starting place. Now for the first time we fly boldly out into space, leaving our familiar slopes far behind. Before starting we must consider carefully the directions of the currents, and it is essential to gain height as early as possible because we are bound to reach a gap between the hills where there is no upwind. By pushing

LANDING UPHILL WITH THE WIND BEHIND!

PUSHING SHARPLY TILL CLOSE TO THE SLOPE, THEN PULLING



R. KRONFELD

PLANE ON A SLOPE IN A FRESH BREEZE

WIND VELOCITY HIGH IN COMPARISON WITH MACHINE VELOCITY.
PLANE AT A SHARP ANGLE TO SLOPE, THEREFORE VELOCITY
PARALLEL TO SLOPE IS LOW

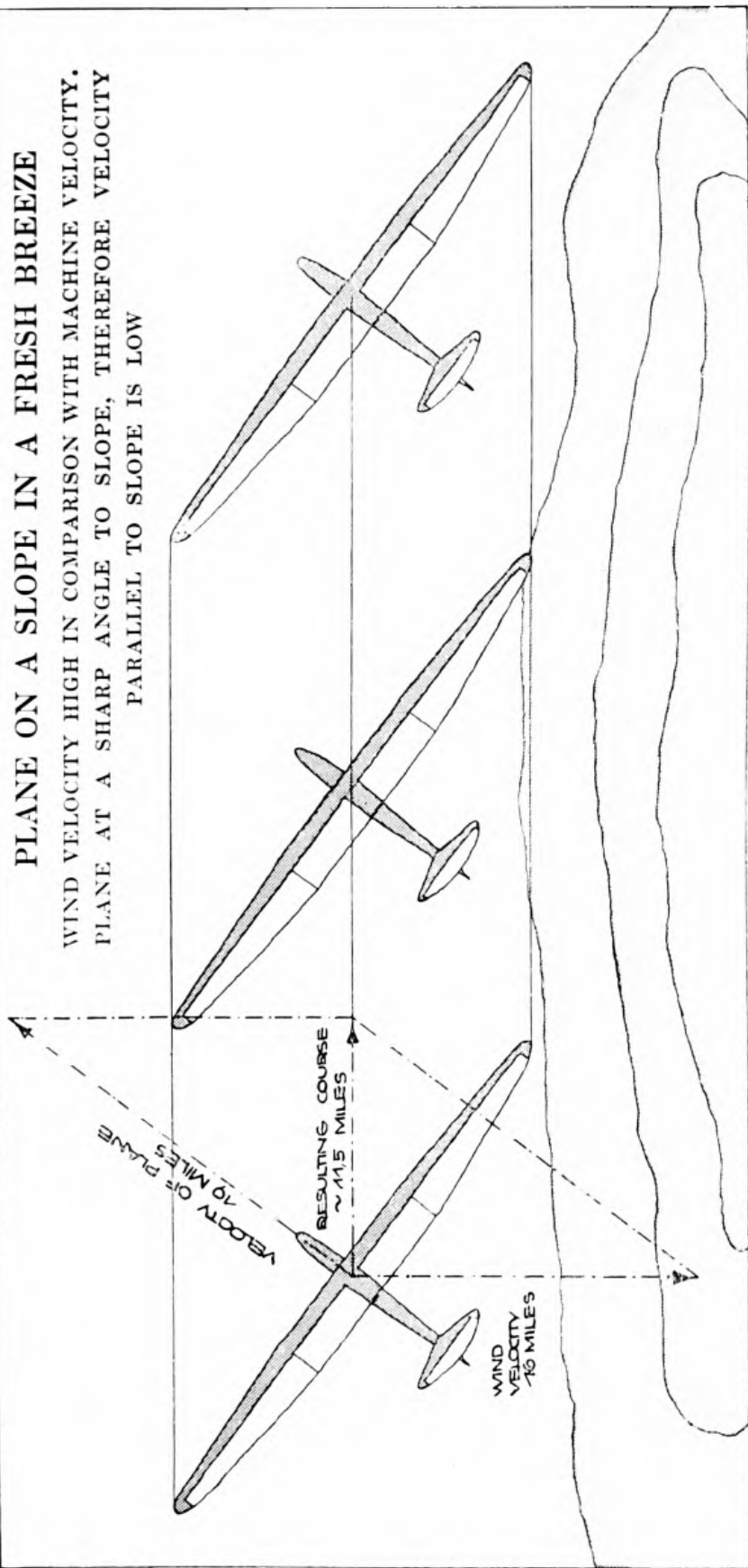

R. KRONFELD

Facing page 195

lightly we must try to cross it as quickly as we can. With our objective clearly in mind, we must at once seek out the slope of the new hillside that lies at a right angle to the direction of the wind, because we have lost height by our glide and must work ourselves aloft again by the help of upward currents. At this stage it is best to go slowly and to tack backwards and forwards over the slope till we have regained the necessary height. When the wind is irregular, this may take quite a long time, but if you can catch it at the right moment (when there is a strong gust, for instance) it is easy to attain the desired height. Everything depends upon a correct and speedy decision at such a moment, as hesitation will mean further loss of height; should this occur we must prepare to return as soon as we see that the altimeter is beginning to fall, and if we make correct calculations, we contrive to cross the gap where no upward current is to be expected at the moment when the wind is at its lowest. The advantage of this is that we head straight for the goal instead of being compelled to tack against the wind. The most favourable turn of events in such cases is a lull between two gusts for a period just long enough to enable us to cross the bad space. Then we can count upon finding on the further slope the currents that help to push us up again, even if we have dropped very low in crossing. This time it will suffice if we climb just high enough to be sure of landing at the original starting place.

Much can be learnt by such a simple flight along hillsides, and later we must try to extend our flights. It is by no means easy to make sure of crossing the gaps between slopes or areas of downwinds, but on such occasions it is often useful to make preliminary tests by pushing out for short distances from the slopes where we are sure of a good upward current. The skilled flyer will soon learn to judge the possibilities of crossing the gap by the way in which the plane falls. If he finds his trial effort is attended by too great a loss of height he must turn back quickly, and must only make a new attempt when he has reached a higher starting point than his former one.

The pilot who reaches a really great height above the slopes on such flights will find a great difference in the

behaviour of the upward currents. He no longer drops into the gaps on the hillside ; he can fly far out behind or before the hill without losing height ; he no longer feels the small individual currents thrown up by every tree or fold of the ground. The region in which he finds himself is a broad, tranquil one which is less affected by the inequalities of the slopes than by the general formation of the range. Over the ridges which are points of junction for several valleys that are exposed to through-winds, the pilot will encounter vast columns of rising current, and these are the principal factors to be reckoned with when he is too high to distinguish the separate slopes and high enough to discern the general outline of the mountains.

Equally important is the influence of heat currents. A day on which the sun pours down hot rays into the valleys gives us a far stronger upwind than a cool day, and this upward rush of warm air will often help us to cross gaps that would be impossible to negotiate at other times. Such warm up-currents are generally to be found above houses, cornfields and rocks.

These factors may influence a pilot to make considerable revisions in his plans, and on hot days we cannot give our eyes' entire attention to the conformation of the slopes. We must take careful note of the patches of sunshine and shadow and keep a constant look-out for places that will be likely to be warmed by the sun's rays.

By the rules that govern soaring flights we must always choose a wind with a direction that is as perpendicular as possible to the general trend of the ridge when undertaking a long-distance flight. It is impossible and unnecessary to attain great heights, for the flight is in reality a series of hops from slope to slope. This is the ideal way of acquiring an ultra-sensitive air-sense which will enable us to take the utmost advantage of every light breath of air. It trains and sharpens our powers of observation, and improves our flying skill.

On principle precisely the same methods should be employed for flights over a fixed course on a hillside. As, however, flights along special courses can only be undertaken in one direction from a starting point, they are best

accomplished with a partial stern wind. Thus the flying speed will be increased, and it will be easier to cross down-wind areas and valleys.

The correct choice of country is frequently the deciding factor in flights over long courses. Sometimes, when at a distance from a high hill, you can continue to soar in the upwind from some rising ground or the currents to be found at the edges of woods as well as those thrown up by houses, river valleys and railway embankments. By such means it is often possible to cross quite long gaps and prolong the course of the flight very considerably.

A thorough knowledge of the laws of currents is essential. We must know exactly where to expect eddies, accelerated currents or air-pockets. Up- and down-winds are no longer the only decisive factors for the success of a flight, and no one can face with indifference the prospects of flying across a ridge in order to gain another slope. The whirling currents that lie behind it will need careful consideration.

LONG DISTANCE SOARING

UNTIL the recent discovery of the art of flying in clouds and thunderstorms long flights over a fixed course were rightly considered the highest development of soaring flight. They were combinations of the duration flight and the flight to a fixed goal and demanded a higher degree of skill than either of those other two forms of flight.

Up to that time fliers to a distant goal did not venture beyond the areas within their field of vision at the starting point. Before taking off they could survey the entire tract of country across which they were to fly, so that all their flights took place over more or less familiar ground. Also, in the case of the earlier long distance flights, which were comparatively short ones, it was at least possible to study the conformation of the mountain range through field glasses.

In the latter long distance flights (which are really long) this is not possible. They carry us into unknown country, to territory which we cannot see from our starting point ; consequently we encounter new conditions and experience many surprises. Before starting we must endeavour to accumulate all possible knowledge, both positive and negative, about the tract of country over which we intend to fly, and so our work in connection with such a flight begins long before it actually takes place.

In whatever country a prize may be offered for a new long distance flight, the first to gain by it are the sellers of maps and charts. Taking the starting point as his centre, each competitor must endeavour to obtain a clear mental picture of the whole stretch of land over which the flight is to be made. If no starting place is fixed by the rules of the competition, the flyer must consider carefully all areas of territory which offer prospects of an advantageous start.

PLANE ON A SLOPE IN A GENTLE BREEZE

THE PARALLELOGRAM OF VELOCITY GIVES THE POSITION OF THE PLANE AS IT GLIDES ALONG THE SLOPE

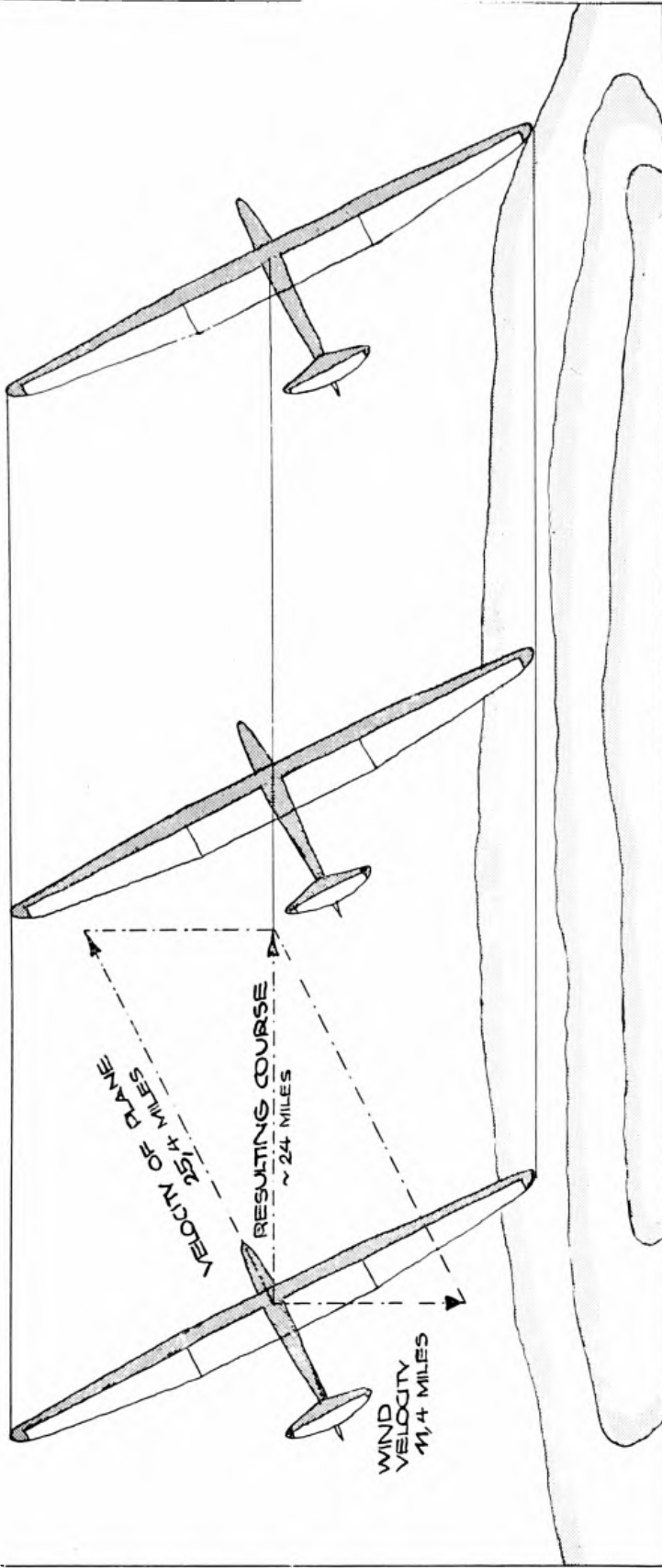

R. KRONFELD

Facing Page 105

CLOUD SOARING

CROSSING THE AREA BETWEEN HILL AND CLOUD IN THE DIRECTION OF THE CLOUD'S COURSE

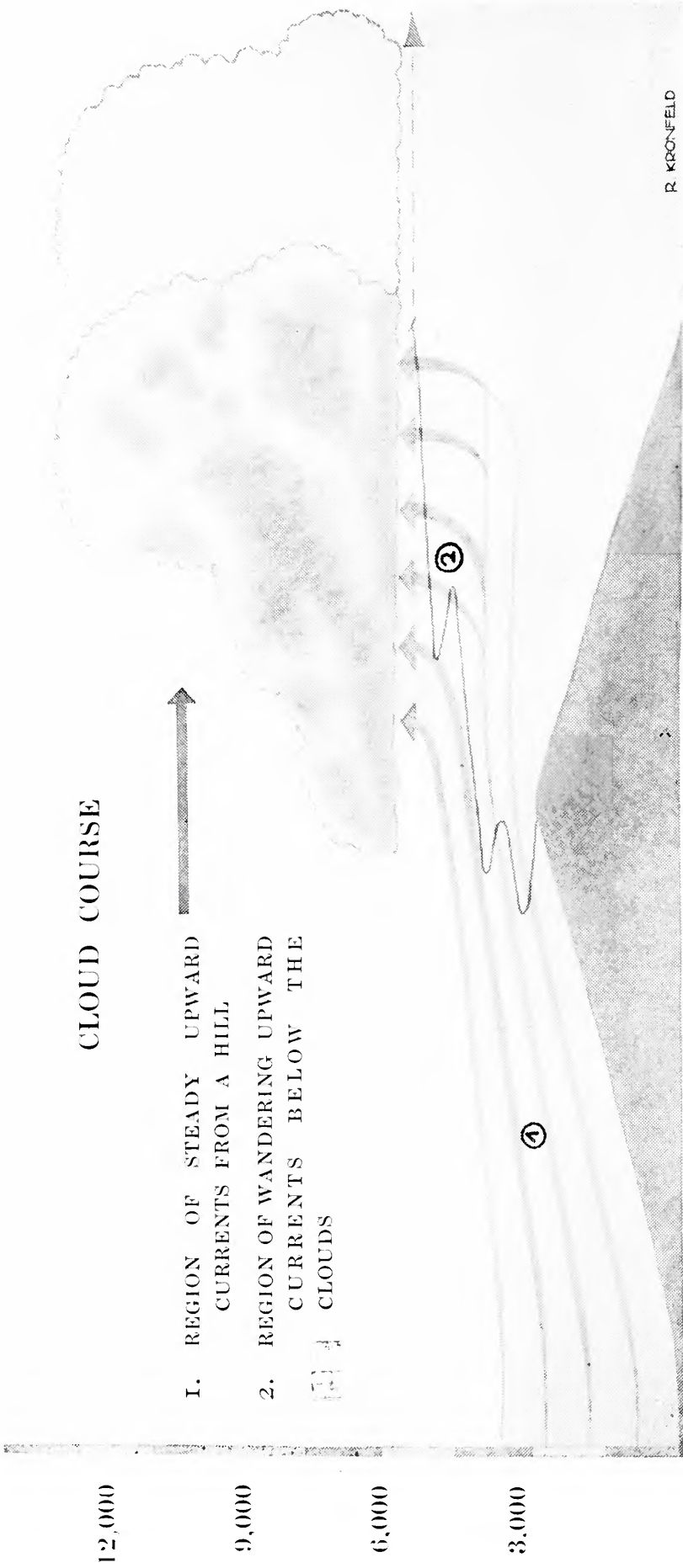

When various stretches of country are feasible, it is always best to choose the one from which the best general view can be obtained or the one which possesses the largest and most continuous range of hills or mountains and the longest ridge. It is important that the general line of the range shall lie at an angle of from ninety to forty-five degrees to the prevailing direction of the most frequent winds of the district in question. There should also be several good places for a forced landing in case of need, as without these a long distance flight is often impossible. If the land is sharply broken up or possesses no continuous mountain chains or ranges, it will be necessary to ascertain the localities where the difficult gaps can best be crossed. High soaring slopes give us the best chances to cross valleys and plains and carry on in spite of the down currents the latter cause if we can contrive to gain enough height on the former. The conformation of these slopes must be such as will enable us to fly with the wind partially behind us all the time. As in the case of flights to a distant goal, we need not worry about how we can return to the starting point, so that our entire efforts are concentrated on flying ahead in one direction. With the wind more or less behind us, our speed is increased, so that we can push on swiftly over difficult places and glide a longer distance from any height we may attain than we could in a side-wind.

The best way to practise planning out long distance flights is to endeavour to ascertain the most favourable lines of flight under varying wind conditions on a large-scale map that gives details of the mountain conformations. The flyer's eye soon learns to recognize the best courses and the various conditions that may be expected.

But that alone does not suffice. Only a very experienced pilot would be able to carry out a long distance flight correctly by a study of the map alone ; it is therefore advisable to get know the whole course with your own eyes. This involves delightful journeys by motor cycle, motor-car, or on foot in the mountains, and innumerable observations. At various spots where special difficulties may be anticipated, you will do well to light a fire and to

enter on your map the information concerning air currents you will obtain by watching its smoke. From the way in which the smoke rises we can also judge the strength of currents in an upwind area and take accurate note of favourable localities.

Experiments with wind-tunnels are also helpful. If a wind-tunnel of the type to be found in an aerodynamic research laboratory were available it would prove of inestimable value to anyone undertaking a difficult and dangerous flight, as for example one above precipitous rocky walls, by demonstrating the effects of currents under various conditions and circumstances. If such an instrument is unobtainable, a large ventilator will prove an efficient substitute. A rough model of the territory to be flown over is then constructed and exposed to its draughts. By means of a woollen thread fastened to a rod we can easily ascertain the directions taken by the current when agitated from various directions, while if we strew sawdust on the model and then turn on the current we can estimate, by noting where it remains undisturbed, the localities where we must expect to find regions of "dead air," i.e., where no currents will be found.

The observation of obstacles in the currents of rivers and mountain streams is also another good method of training oneself to learn the conditions and circumstances of air currents. It is essential that we should be able to use our knowledge of the laws governing the action of currents, and we must know precisely where we may expect eddies, accelerated currents and air pockets.

Upwinds and downwinds are no longer the only essentials for the success of a flight. We must study the plan of the course and note whether we have to fly over or round the ridges of its hills in order to pass from one slope to another. In the first case we fly over or perhaps even through a tract of air filled with eddies, which may jeopardize the whole flight, whereas in the second we fly in the stream of an accelerated current—a far less dangerous proceeding. The more practice we gain and the finer our capacity for sensing currents becomes, the less preparatory work we shall need for our flights. A pilot who has undertaken

many long distance flights after careful preparations will gradually find his "current-sense" developing to such an extent that he can gauge the directions taken by the currents over the mountains and in the valleys that all form part of the restless ocean of air which covers the earth's surface. To attain such knowledge is the object of all preparatory studies, while the great advantage of these long distance flights is that they inculcate in practical fashion experience that may later prove of incalculable value to every flyer.

Such theoretical studies are a stimulating occupation which provides us with many fascinating problems. When you believe that you have mapped out an ideal long distance course, how aggravating it is to discover that you will eventually have to land on the roofs of a town, the tree-tops of a forest or the surface of a lake if you are to take full advantage of your height and gliding angle! The ideal course is one on which your flight is bound to be successful provided that wind and weather do not leave you in the lurch. A sound knowledge of meteorology is invaluable for long distance flights. We must know the weather conditions under which a wind from the right quarter may be expected, and when a very long flight is to be undertaken, a study of the laws governing weather conditions will enable us to make allowances for any change of wind that may take place during it. The time of day is another important factor in weather conditions, and in any flight of long duration such changes must be taken into consideration. A drop or change of the wind may compel a premature abandonment of a flight, or a gale, heavy rain, or fog may oblige us to land. All these factors require careful preliminary consideration.

Before he starts out on the "long trail," the participator in a distance flight draws up his plan of campaign, in which he provides for all emergencies, likely or unlikely. The quality that stands him in best stead is versatility; he must be prepared to cope with many various situations on many different slopes. He must bear all possibilities in mind, and know exactly what to do for the best if the wind changes sooner than he expects or the hillside on which he looked

for a particular kind of current should turn out to have a quite different one. In long distance flying the head must do more work than the hands.

But there are exceptions. They are to be found in those territories which are, geographically and meteorologically, specially favourable for soaring flight, and consist of coastal areas where unbroken dunes extend for miles. In such localities there is usually a regular wind—often so regular that we know exactly when it will occur and in what strength. There are, also, mighty mountain ranges which present unbroken natural barriers and day after day produce a wind that blows in a constant direction. In such regions soaring is easy and opportunities for long distance flights are more frequent than elsewhere. When judging the respective values of flights, it is therefore essential to take into consideration the conditions under which they were carried out.

And now for the actual flight ! The start and the earlier stages of every long distance flight are exactly the same as those of ordinary slope flights. The pilot soon begins to make all kinds of observations which may be useful to him later. We are aware that, according to temperature and weather conditions, the upward current is on one day more directly above the slope, while on another it rises before it ; we can hardly tell beforehand where it will be, but it is very easy to ascertain its locality in the course of a few turns over the whole area. While doing this, we can generally judge whether the upwind is bearing well, whether we ought to fly carefully, taking advantage of every inch of height, or whether the whole upwind area is favourable enough to give us ample scope for liberty of action. Very important also is the frequency of the gusts, which varies considerably under different weather conditions. On such a first reconnoitring flight within our own familiar territory we can see at what intervals we may expect gusts or cessations of the wind, whether they recur regularly and what is the degree of their strength. While we are finding out all these things, we are rising steadily until we can climb no higher, and then comes the moment when we may finally decide which of our projected and carefully

planned flights we will carry out. We must choose the plan which seems best suited to the day's conditions.

And now we will glide to the next hillside, and soon ascertain that there is a good use for all the knowledge we have acquired. Duration flights have taught us to wait for the favourable moment which we can use for hopping over a gap. Everyone has, at one time or another, watched the waves of a stream ; often one of them seems to remain poised at the same height for a long time, then suddenly it rises violently—only to come crashing down the next moment. An accidental encounter between single eddies and impulses is the reason of this phenomenon, and a similar one takes place on slopes. The flyer's problem is to hit upon the precise moment when a special increase in the energy of the upwind occurs, and we may often have to wait long for such a moment. The tranquil patience we have learned in endurance flying is a good preparation for us in such cases.

Now we fly onward, continually losing height. We discover that the wind has dropped. We are over such a low slope that if it decreases further we shall be obliged to land. There is only one thing to do : turn back. So we now fly quickly back to the last favourable high slope, and in order to reach it we recall to our memory all the experiences of our long distance flights to a goal and back again. In these flights we have learnt what we ought to do in the present emergency, i.e., we must wait on our favourable slope till the wind gets up again. This often means a very long delay, for we dare not resume our journey until we are sure of a strong, steady wind.

The straight way is not always the shortest. This is a truth that soaring teaches us most emphatically, for the round-about way often plays a great part in long distance flying. Often a flyer deliberately chooses to go out of his direction if he finds a favourable upwind by which he can gain a considerable height. The extra height amply repays him for apparent loss of time.

The hillsides over which we fly do not seem strange to us—nor do the weather conditions. We have worked their problems out beforehand and have now the pleasure

of seeing our surmises turn out correctly. Of course there are bound to be some incalculable elements which will test our powers of rapid action and thought ; much depends upon our capacity for drawing rapid conclusions in such emergencies, and often unexpected events or obstacles may compel us to change our route or adopt an entirely new one. There is continually something to observe, to consider, to decide.

From time to time our whole mind must be concentrated on the actual flying. Although we may have mastered our art so well that it no longer gives us any trouble under normal circumstances, yet when we find ourselves suddenly face to face with difficulties or serious problems we realize the necessity for concentrated attention. Perhaps we want to glance simultaneously at the speedometer, the map, the compass and the landscape because we have to make an instantaneous decision how to get our bird out of a slip into which she has been thrown by an unexpected squall, while at the same time we cudgel our brains to ascertain where this squall has come from, how it will behave and whether we can make any use of it.

In the meantime we are soaring steadily on from slope to slope. We find that when we have attained a sufficient height we can fly for long stretches with the wind partially behind us. But we find it difficult to make adequate use of upwind areas while we are speeding along so swiftly, and so, when we find that we have lost considerable height, we turn slightly against the breeze and maintain ourselves as long as possible in such an upwind area in order to climb again.

By this time we are far away from our starting point and over unfamiliar ground. We take the utmost care to approach each new hillside from the right direction. "If I only knew where this breeze is coming from," we think, and how often has every pilot that undertook a long distance flight given vent to similar thoughts. He noted the direction of the wind at the starting place, and by his compass he still recognizes the cardinal points ; if he had no compass, he could still identify them by the sun. But after several hours of flight over unknown country it is

extremely difficult for him to know whether he can count on the wind remaining in the same direction. If he had water under him, a big pond or a broad stream, or, better still, a lake, it would be easy. By waves and spray he could at any rate see in which direction the wind is blowing down below. And an even greater help is smoke from a chimney, while the cloud of dust raised by a motor-car has often been of the greatest service to a flyer in a moment of despair. Other useful factors in determining the wind direction, although the signs are more difficult to read, are the weekly washing hung out to dry before a cottage and the motions of tree-tops or standing corn. Weathercocks on church towers or factory chimneys are less reliable, for often a man who has trusted one of them blindly realizes when he has been forced down to land that they have maliciously rusted themselves into immobility. Better agents for determining the direction of ground winds are the small smoke bombs which the pilot can drop out of his plane and the smoke landing signals that are employed for the guidance of aeroplane pilots of traffic routes. But the disadvantage of all these signs is that they only inform us how the wind is blowing close to the ground, and we frequently find that higher up, over the hillsides, it is behaving quite differently. When clouds are in the sky, the course of their shadows on the ground will tell us the direction of the wind in the cloud region, and if by careful observation of the ground phenomena we succeed in ascertaining the direction in which the wind is blowing low down, then we should be able, if we calculate our elevation correctly, to discover the course of the currents at our flying-height. Another method of ascertaining from which quarter the wind is blowing is as follows: take two turning-points and turn repeatedly above them, noting by means of a stop watch whether or not you need more time to fly in one direction than in the other. You can thus discover whether the wind is blowing from the direction of the one turning-point or the other, or whether it is blowing at right angles to both. Also, when flying over a familiar landmark, if you drop a piece of brightly-coloured cloth or paper, and then, making a short circuit, fly back over the same spot, a careful

observation of the course along which your sign has been blown will give you the exact direction of the wind.

All this is of far greater importance than may be imagined until one makes one's first long distance flight. Many fine feats have had to be broken off unfinished because a false computation of the wind's direction has led to the faulty negotiation of a hillside. The soarer is always dependent upon the wind ; he uses it, flies with it and fights against the difficulties which it creates for him. He must be intimate with the wind, must know its nature and attributes, and be able to make use of them. Therefore on every long distance flight, on every new hillside, our first inquiries must always be : from what quarter does the wind blow, how do its currents divide, what is its direction above and below me and at the height of my course ?

And as the element in which we move is an ever-changing and multiform one, we must accommodate ourselves to it, instead of clinging blindly to preconceived notions. We must be as changeable as the wind in our thoughts and decisions. Let this be our golden rule. The best planned flight must often submit to drastic alterations at less than a moment's notice. There are always three matters of grave importance which must be constantly in our minds—the plan, the reserve plan and the possibility of a forced landing. Upon our ability to recognize instantly and clearly at a given moment the right thing to do depends the success of great flights. Failure to act correctly may mean a damaged machine or an injured pilot.

Just this point of the forced landing is frequently neglected. The man who has a clear conception of the possibilities of the development of force latent within both up and down winds, as well as of the astounding suddenness of their manifestations, realizes that he may at any moment be carried up to an amazing height in a few seconds. The opposite can also occur ; he may have been flying on the most beautiful upward current at a good height above the hillside, and then a few seconds later an unexpected downwind forces him to earth. This uncertainty alone should lead us to keep the possibility of having to make a sudden landing continually in the background of our minds.

The habit of continually looking out for spots which would be suitable for landing becomes in time so thoroughly part of our subconsciousness that in the later days of our flying career we never need to give it a thought. Broad meadows and fields come into our field of vision and are noted and registered in the memory. If we need them they are there, ready to relieve us from the necessity of devoting too much thought to them.

Every landing made by a flyer on a long distance flight is a forced landing. The true sportsman never ends a soaring flight till he must ; his sole desire is to fly as far as he can.

And now let us imagine that we have exhausted all our resources. We remember from our study of the maps that in all this neighbourhood there is no slope which would enable us to fly farther that we can reach at our present gliding angle. Once more we concentrate upon the question of how to fly on as far as possible. Hitherto upward breezes have aided us, and perhaps they may help another competitor to fly as far. It is now a question of flying on and proving which is the better man. A few extra yards may mean a new record, and it is at moments such as these that old records are broken.

We know that we can make the most progress if the wind is behind us. But we must anxiously avoid every downward breeze. Below us lies a plain, intersected by a river, the course of which shows us the gradual fall of the land, and the thing we most desire to see—the lowest point in the landscape. Every downward yard is of importance. We take for our objective the lowest point which lies approximately in the direction in which the wind is bearing us ; if the direction of the wind and the slope of the land are not the same, then our air-sense and experience must tell us which of the two lines of flight is likely to take us farthest. But, most important of all, we must note the landing possibilities in each direction.

We can cover the longest stretches when we do not need to pay any attention to the country beneath us, because we know that there are broad meadows to land on. Then we can let our bird float as far and as long as she will, and

when she can fly no longer she will settle down of her own accord, after we have succeeded in squeezing the last ounce of energy out of her. But it is a different matter when we are flying over a stretch of country which offers fewer good landing opportunities. Here is a splendid landing place perhaps, but the next one is two miles farther on. We try to make up our minds whether we are high enough up to fly over the tree tops of a neighbouring wood to the more distant field or whether it would be wiser to come down now. These are the most difficult moments for a pilot who is out for a record. The greatest and most successful exploit and the worst failure are often separated only by a hair's breadth. A man with three or four feet of height over his competitor may succeed in flying over a rocky ridge into the next valley, and beat a world record. The other man makes a mistake and smashes up his bird.

While we are floating in these final minutes and moments of a flight, two thoughts are always in our minds : A little farther, just a little farther ; but—no accident ! You are weary, you have a long and daring flight behind you ; even though you do not realize it, you are tired out. Everything depends upon the next few seconds ; pull yourself together, sharpen your wits. The fairest crown of such a proud flight is a smooth and faultless landing.

All such experience is useful to us in long distance flying. And there are other things, too—a thousand little experiences that steady practice brings. A sharp observation of details or a correct identification of some phenomenon we had never before seen from the air may often turn the scale. A wisp of smoke from a chimney, blowing along a hillside and then suddenly rising straight into the air shows us an updraught where normally none might be expected. A carefully planned flight has frequently been altered on account of smoke when it so happened that the housewives of the district were cooking their dinners at the time when the airman passed. It is well to time your flight so as to reach the most difficult country at an hour when you may expect the greatest number of smoking chimneys as wind-pointers, and it is therefore unwise to make long distance flights through industrial territory on

Sundays. For precisely the opposite reasons we may count upon the help of the dust raised by touring cars in sparsely populated country at the week-end. On normal days we find the strongest current of warm air in the afternoon, when the sun's heat is strongest and the valleys are thoroughly warmed. Therefore on such days it is advisable to time your flight so as to pass over doubtful spots during the afternoon. Birds of prey, which usually sail on a good upwind, are the best counsellors for long distance flyers, but their example must be followed with discretion, for their interests are not purely sporting ones. They may be seeking food, so that the struggle for existence keeps them a long time in neighbourhoods where the upward breezes are not particularly good.

How often have I heard men grumble at "those silly birds." But the birds are anything but silly, and I think that if we took as lively an interest in the hares in the thickets as they do, we should probably fly in their fashion.

And always and for all flights the motto is: "Never give up!" Never own yourself beaten until there is absolutely nothing left for you to try! Until the machine is at a standstill, the flight is not ended. Even if the skid is only an inch above the ground and already swishing through the grass, you are still flying; there is always a possibility that a slope may take an unexpected turn, or a breath of air or an unexpected eddy may come to your aid. Then up you go once more, to fly onward for miles and miles. Never give up! Clench your teeth and let every nerve in your body be on the look out for all possibilities. Show fight to the very end!

Such is long distance flying, and is it not the most wonderful of all sports? It involves not only flying, but also thinking, choosing, deciding. We learn from it self control, we learn to master the forces of nature and our own weaknesses. Everyone who has flown a motorless plane over a wide stretch of country, if even only once, will recognize the truth of what I say, and this is why those who have once begun can never give it up.

CLOUD SOARING AND THUNDERSTORM SOARING

THE finest features of modern soaring flight are the constant new opportunities, struggles and diversions that it offers us. Not so long ago long distance flights were its main attraction, but in the year 1928 cloud flying became popular, and a year later we had grown so greatly daring that we harnessed the thunder to our use, and thunderstorm flying was added to the list of new sports.

Three forms of cloud flying are to be distinguished : Flying beneath the clouds, in them and above them. Not all clouds can be flown in, and it is the province of meteorology to explain precisely how such clouds are formed, the nature of their upwinds and the laws which govern them. For the pilot it suffices to know the appearance of a cloud in which it is possible to fly.

Beneath those beautiful great heaps of clouds, which are called fine weather clouds by country people and cumuli by meteorologists, we find upwinds. The larger they are, the more extensively and the higher they are piled up, the stronger is the rising current below them. The pilot has an intuitive feeling that the cloud is drawing him to it. We shall discuss the reason of this later.

We begin as usual by soaring along a hillside. The task which we have undertaken is to learn cloud soaring, the first stage of which is soaring under the clouds. For this our normal procedure is, as it were, inverted. We no longer look downward but upward to make our observations and take our bearings. The skyscape with its cloud hills and valleys must rivet our attention even more than did the earthly landscape to which we have till now belonged. Formerly, when soaring for longer times on hillsides with beautiful clouds sailing above us, we probably noticed that the influence of these clouds extended to layers of air

lying far beneath them, and the phenomena we generally describe as gusts are found to be mainly due to the influence of a passing cloud. At the moment when such a cloud passes above us the area of upwinds suddenly increases and we climb high, only to drop again as soon as it has passed. But if we obtained in this way only a slight increase in height without coming under the direct influence of the clouds, the phenomenon would still be of use to us. It would always be an important aid to us when we have to cross gaps in slope soaring. Even if we could not quite get away from the upwind on a slope, our chances of reaching an opposite slope would be greatly increased if a cloud chanced to be standing directly over the intervening space or if, by the help of a cloud, we could gain the additional height that would enable us to push across the difficult spot.

But this is not what we mean by cloud soaring in the true sense of the word. Just as slope soaring is soaring by means of the upwind above a slope (which wind alone bears us up), so true cloud soaring must be soaring in the upwind under a cloud, without any dependence upon slopes. The slope would only be used as a kind of jumping-off ground to enable us to pass across to the cloud. The first and most difficult thing to learn is how to achieve contact with the clouds.

Hitherto we have had to deal with stationary upwind areas, that is to say, areas that are always to be found at the same locality on a mountain slope as long as the wind blows from a certain quarter. They are local, and may be described as fixed. The upwind area of the clouds is a wandering one; like them, it drifts over the land. Our task is to cross from the fixed to the wandering. As we spring from the firm ground on to a moving tram, so must we spring from a slope to a passing cloud.

Looking at the business in hand from the point of view of the plane, we are concerned with two directions of movement—that of our machine, which, generally, like the position of the slope, lies athwart the direction of the wind, and that of the clouds, which is identical with that of the wind.

Cloud soaring is still a very young sport, but already we

can distinguish between two different methods of obtaining contact. The original method was to cross from the slope to the cloud just as the latter was passing directly over the former. We call this "a hop across" in the direction of the cloud course, and our best preparation for it is to climb as high as possible while the cloud is still approaching. We soar up into the highest layer of air to which we can attain by means of slope flying, and as we cannot rise higher and do not sink deeper, we may describe such layers as "floating layers," because we neither rise nor sink, but simply float. Then comes the cloud; if we keep our plane more or less over the same position, we suddenly begin to feel jerking gusts of upward wind, which will lift us for a short time until we reach a boundary layer between the sphere of action of the slope and that of the cloud. Our problem is to slip from the one to the other, and this can often be done quite easily with vigorous movements. But often we find it necessary to make skilled use of one of the gusts by pulling ourselves into it as far as is feasible and then trying to climb with it. The altimeter shows us whether we have succeeded, for in that case it begins to mount steadily. We climb jerkily in sharp upward gusts, and at last we attain the realm of the clouds. From this moment we must change our manœuvres, for it is not possible to tack in figures of eight as we do above the slopes.

The upward wind on a slope rises in the form of a more or less broad stream in front of and above the line of the hills or mountains. Cloud upwind, however, may be pictured as rising like a tube beneath the cloud. Its shape is determined by that of the base of the cloud, which is generally round, or nearly so. The best figure to describe is therefore a circle, and so we fly in vast rings under the clouds. Our movements resemble those of the birds, which sail upward in the same way but can make use of smaller upwind tubes because of their own smaller size. These smaller tubes are usually too insignificant to be used by our big machines.

There are considerable advantages in this method of getting into contact with a cloud by passing on with it from

the slope. By careful observation of our altimeter, we can ascertain beforehand the sphere of activity of the slope upwind, so that we know at once when we begin to feel the cloud upwind. At the moment in which the moving and the stationary upwinds are over the same spot their forces are united. From our base on the slope our progress to the cloud resembles the climbing of a ladder of wind on which we can mount easily, and the whole manœuvre occupies only a comparatively short time. If for any reason the start is delayed until the last moment, this is the only right way to get into contact.

Nevertheless it is just this question of time which may prove a drawback. If anything should happen to prevent the contact, the situation of the pilot is a precarious one. He has tried to travel on with the clouds and has drifted far behind the slope, but now the spirits that bore him up suddenly forsake him. The cloud wind does not help him because it may be too high or too weak, and the slope upwind he has left far behind him. At times we are lucky enough to get back to the hillside by gliding against the wind, but if it is too strong we find that we are making no head against it ; we push in the endeavour to gain more way and find that this is useless ; we have reached a dead point. Then all at once we encounter a down wind, and a painful landing in the valley is the result.

In order to avoid these disagreeable possibilities a second method of gaining contact with the cloud upwind has been discovered. This is to fly towards it, and it is an excellent plan when the sun is emitting great heat so that we may expect large quantities of warm air to be rising over the plain and in valleys far away from the hillside. We work ourselves up high above the slope ; then we choose a large cloud which approaches us from a distance. We wander towards it, keeping a sharp eye upon the altimeter ; if it begins to fall, we turn back instantly and drop down to the hill. Like a snail that stretches out its feelers and retreats into its safe house as soon as it suspects any hostile element, so we grope cautiously in the unknown, noticing that the nearer the cloud draws to us, the farther we can fly towards it. Then comes a moment when, although

we have left the hill so far behind that no upwind could be normally expected, we suddenly begin to rise. We are in the cloud's upwind, and the game is ours. We begin to circle again, follow the cloud in the direction of our hillside, fly over it at a great height and so onwards across country.

The advantage of this flight towards the cloud is its safety. You can always get back to the hill. Even if you make a bad mistake and lose height because you leave the slope too soon, you are in the upwind field again as soon as you turn, for you have the safe hillside always behind you. You need only fly quickly back, assisted by the wind at your back and the good gliding angle that it always gives. Then you can work up once more and push out again. Should your efforts fail, you can always apply the original method at the last moment and cross to the cloud by flying with it in the direction of its course. A second advantage is that you can gain a better general view of the approaching clouds when flying towards them and can therefore select the largest of them at leisure before reaching them.

The danger of dropping down before the slope after a clumsy approach is very slight, although it does exist. But on the other hand we must take into consideration the fact that the repeated attempts which are often necessary before contact is obtained by this method take up much time—a factor which may frequently be of primary importance in competitive flying. The pilot must always decide for himself which of these two ways of getting into contact with his chosen cloud is best for each individual case.

Now comes the question of what to do when we have obtained our contact ; how do we fly with a cloud and how can we use it to the greater advantage in our flight ?

The most natural way of flying under a cloud is that which we have already described—circling. But the cloud is sailing on over the land, and we with it. Our course as seen from the ground is a cycloid, a curve which would be described by a point on the circumference of a rolling wheel. In order to avoid losing our contact with the upwind field it is necessary to fly very close under the base of the cloud, to attach ourselves to it, so to speak. We need only drop down and fly a little lower when we require

ATTEMPT TO SOAR WITH THE CLOUDS

CLOUD BASE TOO HIGH

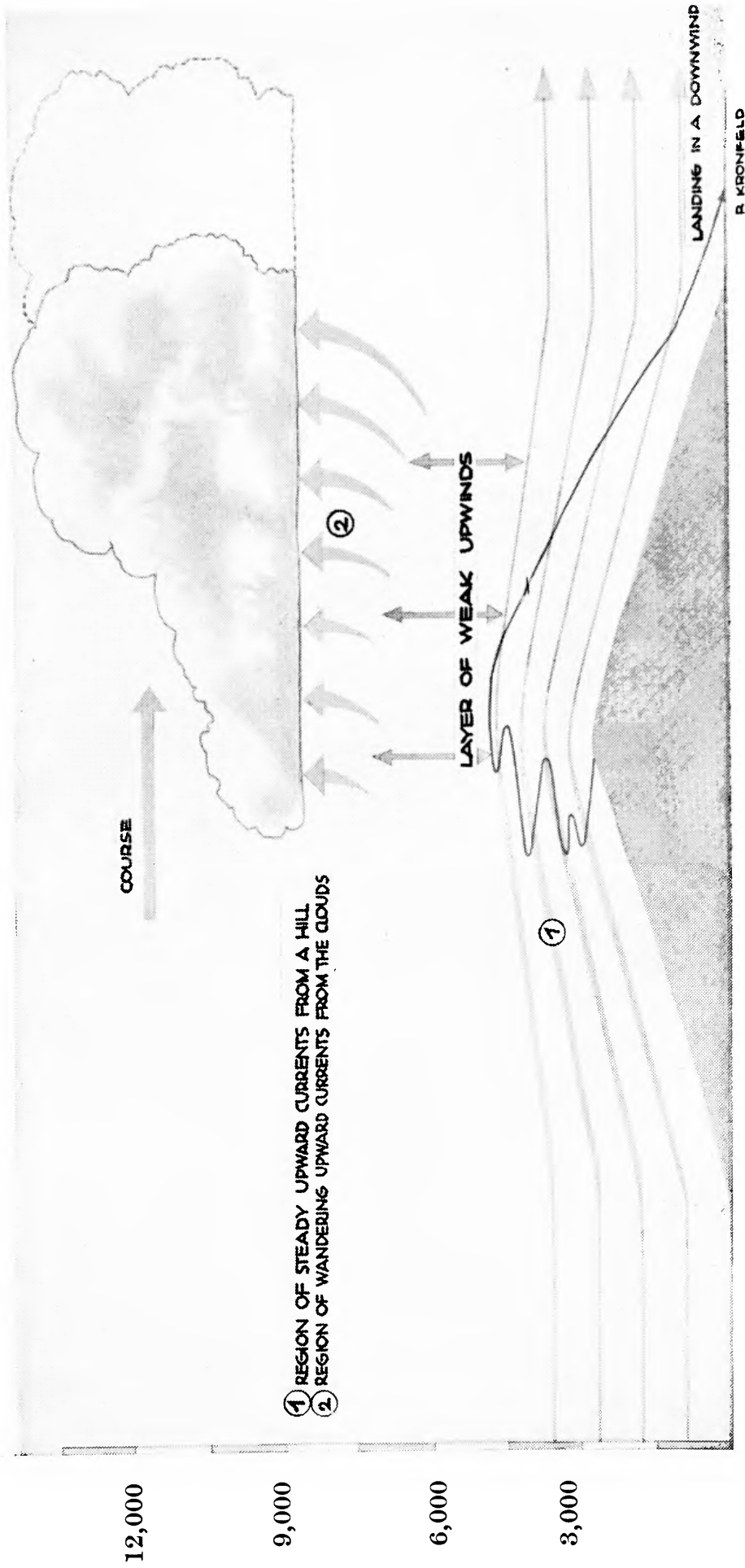

- ① REGION OF STEADY UPWARD CURRENTS FROM A HILL
- ② REGION OF WANDERING UPWARD CURRENTS FROM THE CLOUDS

12,000
9,000
6,000
3,000

CLOUD SOARING

CROSSING THE AREA BETWEEN HILL AND CLOUD IN THE DIRECTION OPPOSED TO THE CLOUD'S COURSE

- I. REGION OF STEADY UPWARD CURRENTS FROM A HILL
2. REGION OF WANDERING UPWARD CURRENTS BETWEEN CLOUDS

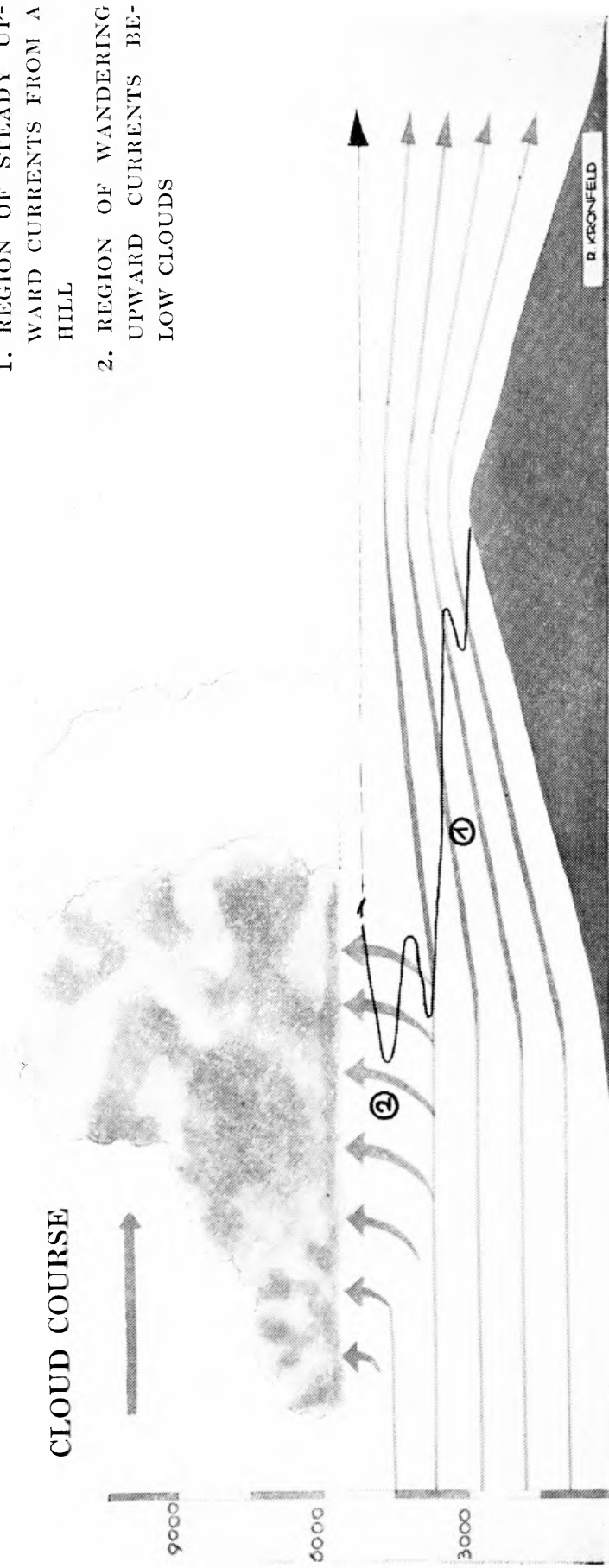

Facing page 215

a general view of the shape and size of our cloud and its neighbours. Directly beneath a cumulus the view is too limited ; we see only the grey curtain above us, with its billows and swirls. It is not possible to ascertain whether or not the cloud which bears us along is the largest and most favourable among the many racing across the firmament. We may always expect the strongest upwind at the spot where the base of the clouds looks darkest as seen from below.

While flying onward we must accommodate ourselves to the prevailing shapes of the cloud masses. Often great rollers of cumuli, bunched together athwart the direction of the wind, drift over the land, jutting out like a hillside slope. As we are sailing with the help of both clouds and wind we are able, in such a case, to describe long loops and ellipses which enable us to turn as we please. We can fly farthest when we fly athwart the cloud when flying with it ; by this means we take advantage of the long drawn out cloud route, flying along it to its end and then moving on before the wind to the next roller, and so on.

But if the shapes of the single clouds are more or less globular, if they are sharply separated from each other and floating some distance apart, then it is advisable to cling to the base of one of them as long as we can. Seen from the earth, the flying velocity is not, in this case, greater than that of the cloud, which, according to the wind velocity, may be anything from ten to forty miles an hour. When we succeed in crossing with the wind from our first cloud to the next one, the velocity is increased by that of the plane's so that we often attain a speed of sixty miles an hour. In the same way that we lose height on the passages across the gaps when flying over slopes, we lose it also when we fly under the gaps between the clouds and are compelled to work up again as soon as they are crossed. Our whole power of vision is now adjusted to cloud mountains and valleys and the changing shapes of the upwinds caused by these.

So far this is all very useful and helpful. But unfortunately cloud mountains, unlike their brethren on the solid earth, have the peculiarity of springing into existence very suddenly, and, what is worse, dissolving with equal

rapidity. Everyone who has flown across country with the clouds must have suffered from the behaviour of these misleading fellows. If you are very lucky at the moment of leaving your hillside you run into a cloud that is in process of formation. You see above you a tiny wisp of vapour, which all in a moment rises and grows blacker, and before you know where you are it has become a huge cloud. The upwind beneath it is very strong, so that you can fly with it for miles.

But often it is another story. Suspecting no evil, you have been flying across an interesting country that stretched in a broad expanse beneath you. The base of your cloud was so high that you sped along at a good six thousand feet above the earth. Suddenly you find yourself dropping. You look up and see your beautiful, round cloud crumpling up and acquiring ragged edges. That is a bad sign, but you have little time for reflection, for almost instantly the cloud that one moment ago was so stately disappears and leaves you hanging forlornly between heaven and earth. If you have not already considered carefully what to do in such a case, there will be nothing for it but a more or less long and unhappy gliding flight down to the plain below.

Clouds disperse above great upwind areas and high mountains, and frequently also above wide, extensive flat plains and sheets of water or rivers. Moreover, cloud formations generally break up towards evening, but the worst of it is that it has not yet been possible to discover any reliable rules for their behaviour. Therefore the pilot who desires to fly safely will do best not to trust himself to cloud upwind alone.

A skilled combination of flying under clouds and along mountain sides will produce the best results attainable by the present methods of cloud flight. In this respect the slope becomes not only a starting place but also a point of support and repose between cloud flights. The elevations reached in cloud flying are so far greater than those to which we have become accustomed on the slopes, that they render possible easy flights to far off mountain ranges. When flying over slopes, we must always be on the look out for good places for forced landings, so, and in similar

DISTANCE FLIGHT TO A FIXED POINT WITH RETURN TO STARTING POINT BY CLOUD SOARING

NOTE: NOT TO BE DONE BY SLOPE SOARING ALONE

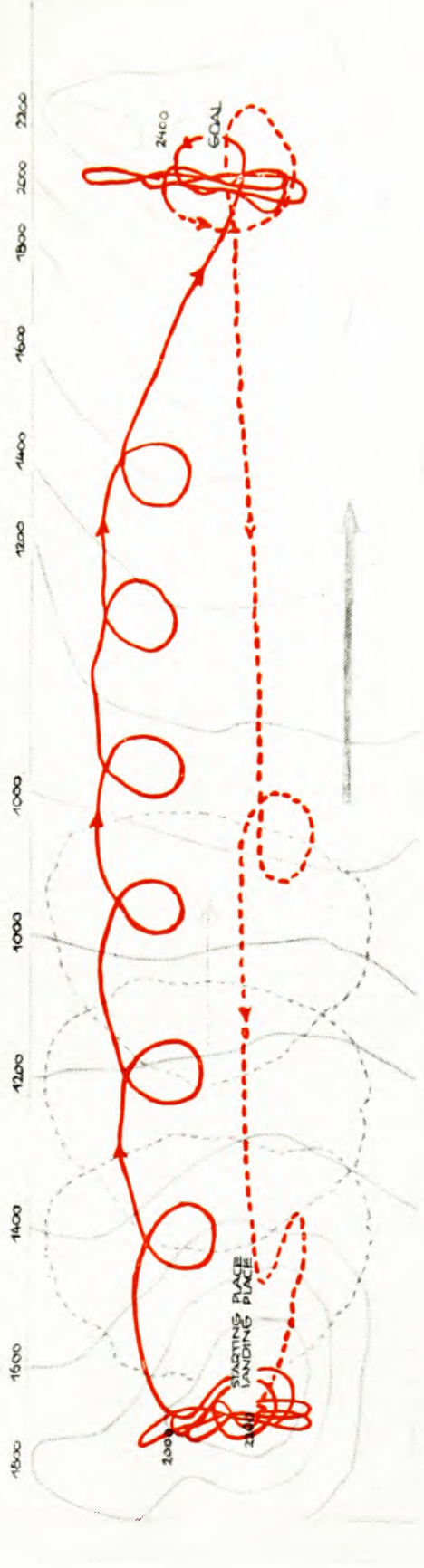

R. KRONFELD

fashion, when circling beneath the clouds, we must keep in our mind's eye some helpful slope to which we can fly if the cloud beneath which we are hanging should suddenly disperse when there is no other within reach. We must then push ourselves down in a glide to the mountains and hover there till another cloud comes along that will bear us onwards.

If the clouds are drifting high enough, it is easy to reach a chosen goal which does not lie directly in the line of their course, for the height attained will enable us to fly to hills which lie at an angle to that course.

This fact is of great importance for flights to distant fixed objectives and has indeed placed such flights upon an entirely different basis. Our experiences of slope soaring have taught us that in flights to a distant fixed goal it is necessary for the main ridge of the mountains to lie at right angles to the direction of the wind. In cloud flying this is not necessary ; we can carry out a flight, in which both start and finish are exactly in the direction of the wind. Only in this case both hillsides must be suitable for slope flying and so offer us a chance of waiting for the approach of the right cloud. It is also very important to know the exact distance of the different mountain ranges from each other. When we are gliding above a slope we can always see the clouds approaching while they are still a long way off, and we generally know the wind velocity by our measuring instruments. If in addition we also can estimate the distance of the mountains above which the ondrawing cloud is piled, it is not difficult to calculate when we may expect its arrival. This is of great importance for the return flight from objective to starting point.

Sometimes we can attain so great a height under a cloud above the starting slope that we can do the journey both ways in a single glide, but this is only possible when the clouds are very high and the distance from start to finish not too great. The surest way is always to rise high above the starting slope and then fly to the goal with a cloud ; there we should wait until a cloud upwind permits us to climb once more and then fly back safely, while constantly hugging the clouds.

From the above remarks the value of these new possibilities for a flight along a course will be clear. The special advantage of the new form of flying lies in the increasing number of combinations to which it opens up the way. We can now spring from slope to slope, from slope to cloud, from cloud to slope or from cloud to cloud.

Soaring, which formerly was closely bound to slopes, is now almost set free from them.

And not only can we fly under the clouds ; we can also fly in and over them.

Let us first try to force our way into a cloud. Sometimes this is quite easy, but often enough there are difficulties. Generally the upwind under a cloud is divided stepwise ; at each stage we climb quickly for a long time ; then we find ourselves hanging in a layer in which we make little progress. But soon the rapid climb recommences.

The last step we have to climb is the base of the cloud. As, rising upward, we enter the cloud, we are met on its threshold by stormy gusts, and matters become worse when we are really inside, for the rounded mountains of the clouds, the wonderful dragons and other fantastic figures which children see in them, are caused by the motions of the masses of air within each cloud.

Even for old and experienced motor-plane pilots flights inside the clouds form a difficult problem. When an empty space is dark, no one in it can see ; everywhere there is nothing but blackness. These are the conditions that a pilot encounters in clouds, with this one difference, that the space is not black but white, and in this whiteness you can see just as little as in the dark. He who has failed to train his flying sense and powers of observation of flight conditions in good time will surely be found wanting, for one important thing is lost to us :—the horizon line.

“ Flying blind ” needs practice. Most soarers have not at their disposal the variety of instruments with which the motor-pilots are provided. Often, too, the dampness of the cloud interiors causes the speedometer to strike work, in which case our sole resource is to fly by ear—by exact attention to the well-known, regular tones of the bracing wires. And now all that we have previously learnt fully

DISTANCE FLIGHT TO A FIXED POINT WITH RETURN TO STARTING POINT BY SLOPE FLYING

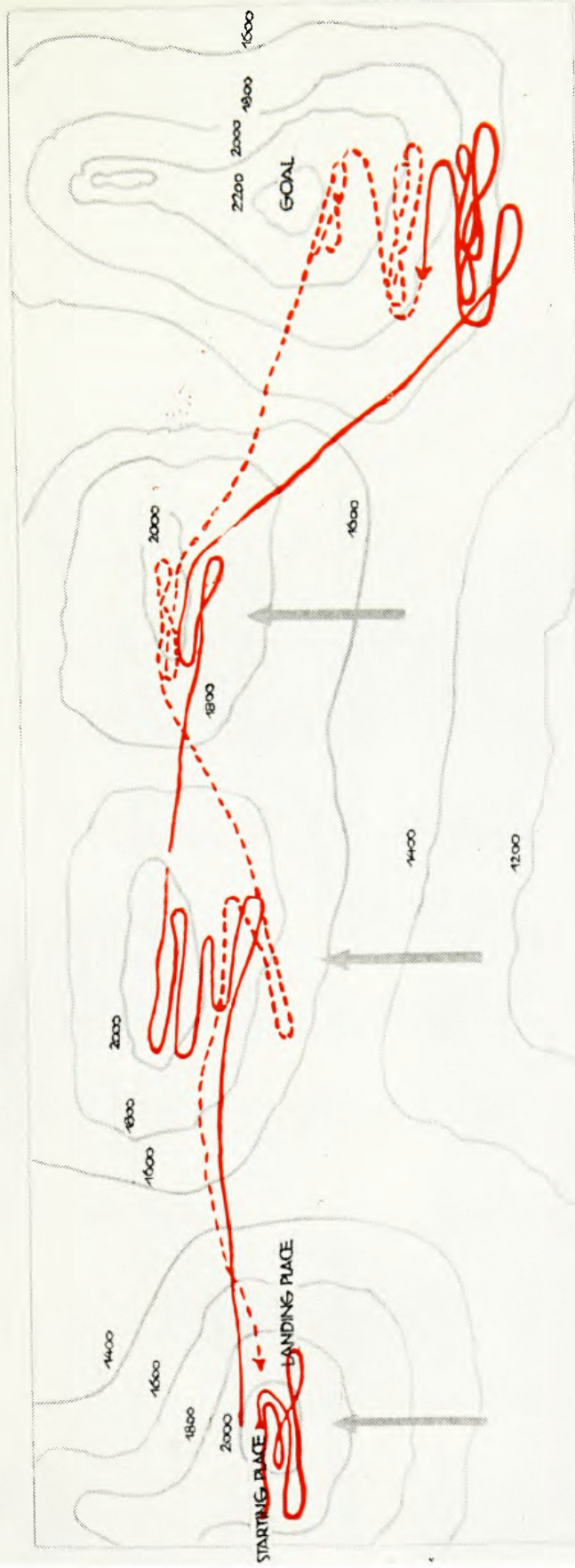
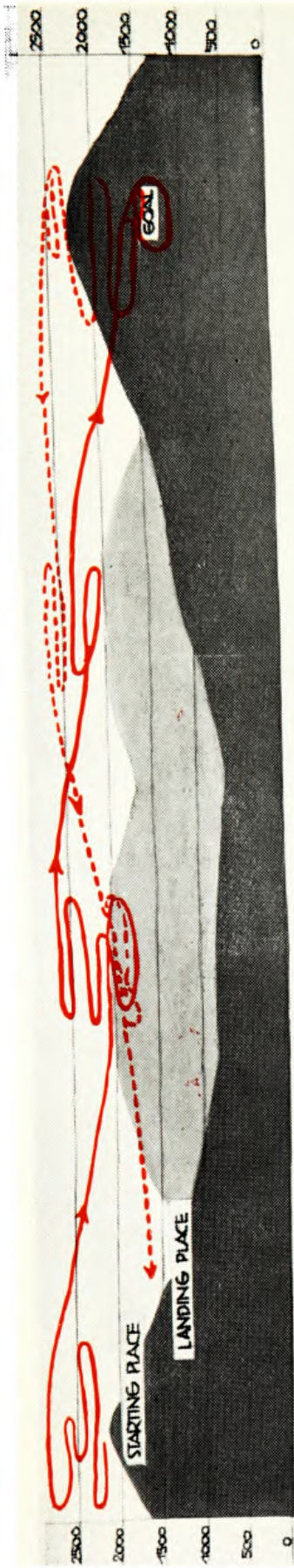

R. KRONFELD

COURSE OF FLIGHT AT A RIGHT-ANGLE TO DIRECTION OF WIND



proves its uses—the more or less well developed feeling for the wind in our faces and the sensitive handling of the controls are a powerful help in such times of trouble. We are also conscious of the forces which make for increased speed, and find ourselves frequently seeking assurance that the steering parts are in their normal positions.

Even when we are in really good training and practice, mistakes cannot be avoided from time to time when flying in machines of a low degree of inherent stability. The violent gustiness within the clouds, far surpassing anything to which we are accustomed outside them, together with the bad visibility, tends to make us over-pull, and then there is the danger of a spin. It is typical of blind flying that we frequently do not notice such a fatality ; we may be right in a spin and merely ascribe the increased whistling of the bracing wires to an increase of speed. We then imagine that we have pushed too much, and so pull, with the result that we spin more wildly than ever. There is, however, one means of knowing whether we are spinning, for if we pull when in a spin the speed either remains stationary or increases. On the other hand, if we have pushed the stick too much, the pull back will immediately cause the whistling in the wires to decrease.

The decisive factor for success in cloud flying must always be the coolness of the pilot. He must depend entirely upon his machine and trust it fully. By reason of its inherent stability it always rights itself even after heavy squalls. The pilot is more or less a sleeping partner in such cases ; he must sense what his machine wants to do, and try to follow its lead. It is more important to save the machine from overstrain by skilful steering than to impose one's own will upon it under all circumstances.

A flight in the clouds requires special caution. The soarer whose plane is not constructed to meet the heavy demands clouds make on it should always carry a parachute. Even if it is not needed, the moral effect is a good one. While the plane is groaning and crackling in every joint, the pilot feels safe and can preserve his equanimity.

When flying over a slope it may be observed that the machine always turns of itself towards the strongest gusts

and seems to seek out those spots where the steadiest currents are to be found. Usually it is not possible in slope flying to surrender oneself to this "intelligence of the machine," but in a cloud upwind it is the very best thing to do. Deliberately we let the plane go its own way; it discovers for itself the places with the strongest wind and brings us suddenly from blindness into the light. When soaring in the clouds, our aim is to climb steeply within them so that we may at last pass through them and fly above the cloud ocean. The rest is easy. We see once more the horizon and the places where a strong upwind blows. Upwinds are generally to be found immediately above the clouds and their strength depends on the size of the cloud. We circle over them, push on to the next cloud peak and so fly onward. Now there are no difficulties; soaring above clouds is much easier than soaring above a hillside or even in the clouds. The one thing which might perhaps be called a difficulty is the problem of keeping in touch with the earth. We have to get our bearings through small gaps in the clouds, and it would hardly be possible to carry out a flight above the clouds profitably without a compass and careful calculation made in accordance with a pre-conceived plan. But even if we have thought out everything carefully, measured the height, ascertained the wind's speed and calculated its course, this method still remains the best, for it is the one which bears us highest while leaving us always free to drop down through holes between the clouds, fly under their bases or to complete a flight over a hillside.

The kind of weather necessary for cloud flying is often at hand, so that it is generally possible to indulge in this highly interesting variety of flight quite frequently. We know of only one form of soaring which is superior to it both as a sport and in grandeur: Thunderstorm flying.

Primitive man was not the only person who found thunderstorms weird and terrifying. They are to a certain extent a revelation of the forces of nature, but this fact does not disturb the trained flyer. He does not worry about thunder and lightning; quite dryly and practically he considers the meteorological processes which give rise to

such storms. Especially suitable for soaring are "thunderstorm fronts."

These "fronts" consist of cold air that pushes itself under warm air. While the cold air moves forward, rolling slowly over the earth like honey spilt upon a table, the great thunder clouds are formed in the dividing layer between the cold and the warm air, and, with the cold air front, stretch out to form a long line.

From a mountain it is particularly easy to watch the approach of a thunderstorm. Here, as in cloud soaring, it is advisable to obtain as much height above the hillside as is possible. The forces of the approaching front will soon begin to make themselves felt, and as in cloud soaring, we suddenly find ourselves climbing strongly, or we become aware of upwind over spots where there was formerly none. Now is the time to travel with the storm, but one strict rule must be observed: always keep in advance of it. If we take this rule to heart, we need have no fear in the presence of this most glorious spectacle of nature. Again and again the lightning flash may light up the gloomy cloud-wall which draws ever nearer, and the thunder may roar as mightily as it will, but the soarer will hasten on before them both.

It is not always possible to start before the storm front at the right moment. But even if we miss it, thunderstorm soaring is possible, though with increased precautions. Very often the wind drops before the beginning of a squall or dies away altogether. It is out of the question to start in this "calm before the storm."

In order to leave the slope we must watch keenly for the sudden, sharp beginning of the thunder squall, and when this comes it is an affair of seconds. He who starts one moment too late will find himself caught in a true witch's cauldron of thunderstorm eddies and gusts, which may be most dangerous for plane and pilot if they occur close to the slope and before any great height has been gained. With the squall comes heavy rain or even hail, and immediately afterwards great masses of cloud generally drift low and shroud the mountains in mist while they unload themselves on the earth beneath.

The start must be made between the dropping of the wind and the moment when the rain begins. The best plan is to sit ready in the machine, with the starting crew at the rope. The anemometer will indicate the moment when the wind has attained the speed necessary for our flight, and then we must not lose a second in starting our flight before the storm.

At its commencement we must gain height as quickly as possible, at the same time keeping the machine well ahead of the storm. We are not yet very high, so that the ground can still influence our flight, and if we possibly can, we must avoid mountains which produce downwind. As we rise, it becomes less and less necessary to trouble ourselves about the contours of the earth below us, but all the more must we study those of the thunderstorm. Quite suddenly small, or even fairly large clouds appear in advance of the front, and it requires sharp attention to avoid being enveloped in one of these. The nearer the wall of cloud draws to us, the more rapidly we rise, and the more difficult grows the struggle with eddies and gusts. To tack before the front as we do before a hillside, or to circle as we do in normal cloud flying, is impossible before a thunderstorm front, which is, however, generally so far-flung that we can fly right along it in the direction we have chosen. But when we are not quite clear as to which direction will help us most on our chosen course, we must be very careful not to fly too far at first.

If, by steady climbing, we succeed in reaching a sufficient height to enable us to see over the storm, the second period of the flight begins. This is known as the period of orientation, and the higher we are for it, the better. Along the whole front strong upwinds prevail. On the boundary between cold and warm air the storm discharges its artillery of thunder and lightning, while its front stretches in the form of a nebular roller which we can see beneath us along its whole extent. There are now two things that we must observe : the line of the front and the direction in which it is travelling. It is easy to distinguish the line of the white cloud roller below us, but hard to say in which direction, from the standpoint of our starting place, it will expand

the furthest. The best thing to do is to fly along it and endeavour to ascertain in which direction our greatest flight possibilities are likely to develop.

The whole front strides forward. From the speed at which the whole moves we can discover where its centre lies, because its motion is the rapidest. In order to calculate this we must so manœuvre our machine until it circles perpendicularly above a spot on the front of the white cloud roller, across which we take our bearings of the country directly below us. And now for the first time we obtain an accurate impression of the forward movement of the cloud masses. If we know the distance on the map between the two places across which the storm is driving and note by means of a stop-watch how long it takes to fly from one to the other we at once have the velocity of the storm. If we repeat these calculations from various points, it is not difficult to discover the place at which the storm front is moving most rapidly. When a thunderstorm dies down after the atmospheric energies have adjusted their balance, then this part of the front which is its true head, pushes on farthest, while the outside edges drop back or dissipate.

Strong is the upwind in a thunderstorm, but the downwind that follows it is equally vigorous. Yet if we are high enough up we can easily distinguish the two sides of the storm. Before the storm on the upwind side we see the land still bathed in sunshine, directly beneath us is the white roller, and behind it lying in gloom and often shrouded in thick black vapour, we see the downwind side. The rain slants down behind the thunderstorm wall, and only occasionally can we distinguish through its dark blue veil the villages and roads that lie beneath us. That is the side that we must resolutely avoid.

The whole art of thunderstorm flying consists in keeping above or in advance of the storm front. This would not be at all difficult if the front always remained orderly and presented a straight edge, but it frequently occurs that thunderstorms split and the two halves go off in different directions. And now the difficulty is to recognize which of them is the stronger, the more vital and the more likely

to travel farthest. Moreover, two such separated thunderstorms may meet again, or may be held up singly in mountain valleys, so it is not too easy to obtain a correct impression. In spite of this we can always recognize the upwind side by the forms and composition of the clouds, for where the air current rises, new white cloudlets are constantly created and hang like clusters of grapes before the storm as they climb upwards. These are the best indicators of the upwind, and as long as we keep above them we shall be able to soar.

By the aid of long-drawn thunderstorm fronts travelling at a great pace it is possible to carry out magnificent feats of cross country flying. If our observation flight has enabled us to study satisfactorily the line of the front, we can now begin our real cross country flight. Immediately above the storm, where we have remained till now on account of the better bird's eye view this position affords, it is generally very gusty, and it may also chance that mighty towers of cloud rear themselves up to our height from the roller. They are often so high that it is impossible to fly over them, while to fly round behind the storm would bring us into downwind. While soaring across country with a thunderstorm it is therefore best to maintain an oblique position before its front, as we are thus able to regulate the height at which we desire to fly above the ground. If we fly far before the front, it may easily happen that the altimeter will register a slight loss of height, but this is of no consequence, for if we fly onward we find that the plane does not continue to sink but remains floating at a certain level. The farther we hasten on in front, the lower will be the level at which we can remain, which is very advantageous under certain circumstances. On close, thundery days it is often difficult to get the view of the ground necessary for purposes of orientation from any considerable elevation, but if we drop down we can make intelligent use of our maps. Moreover, there are no gusts in this zone, which is several miles ahead of the front. We float tranquilly along in much the same way as we fly overland in a light power-driven machine ; if we lose too much height, we drop back towards the storm wall and immediately begin to rise again.

The finest thing about thunderstorm flying is that it affords us the best means of rendering ourselves entirely independent of the hill slopes. Often it is unnecessary to fly backwards and forwards or tack before the slope ; we just fly straight out, without the slightest turn, along the front of the roller. We are sky-high above the slope, which has lost all its influence on us ; as long as the storm travels and as far as it extends, we can travel with it.

Nevertheless the very finest flight possibilities are to be obtained by a skilful combination of all the various forms of flight. It is easy to imagine how we may take advantage of all the different kinds of soaring on a single flight.

The pilot starts from a hillside slope, having flown along it as far as he can. At the end of it he waits till the chance comes to fly under a cloud to the next mountain range which is no great distance away. From this he flies off again, and soon finds himself confronted by a great gap which it is impossible to cross unless he can gain height considerably. This he does by waiting for a mighty cloud, which he climbs through ; he then flies with and above it over the broad plain to his next point of support. If he has started off on a day on which the weather forecast indicates the probability of a thunderstorm, he has hit upon the very happiest conditions for long distance flight which can possibly be expected from our present knowledge of soaring flight. If he actually succeeds in getting into contact with the thunderstorm and in flying with it across country, and if he is capable of steady endurance, then this flight is bound to develop into a prodigious exploit. It is often possible to spend a whole day in the plane by making use of the successive changes in the weather conditions.

We see how the methods of high efficiency soaring flight have been built up by experience gained in endurance flights, slope soaring, cloud flying and thunderstorm flying, and we must learn to take advantage of all these, singly and in combination, according to our needs. The possibilities of these various kinds of flying, particularly as regards cloud and thunderstorm flights, are by no means completely exhausted. By making use of our present knowledge of

them, we can already plan to fly for many hundreds of miles, at a height of thousands of feet above the earth.

By the vast increase in skill and efficiency which they have brought with it cloud and thunderstorm flying has raised soaring flight far above the mere sport of its infancy on mountain slopes into the region of difficult scientific aerial research work. Such a flight as the one I have described above is not merely a struggle that brings out and develops the virile qualities in a man, but is also an enterprise and an adventure where new problems are constantly offered for solution.

He who has made high efficiency flights in thunderstorms and with clouds knows well that there are forces which will not yield to horse-power. Victory over the mightiest forces of nature can only be obtained by wisdom, courage and thought.

AUTO AND AEROPLANE TOWING

THE methods of instruction employed for pupils learning to glide and soar along slopes are known in their homeland as the "classic school," but in other countries they are often termed the "German school" after the land where soaring flight was brought to its present standard.

Nevertheless, deductions made from practical experience and theoretical study impel us to answer in the negative any questions as to the likelihood of these methods remaining unaltered in the near future. Experts and amateurs alike are gradually inclining to the opinion that the future of soaring flight is linked with auto and aeroplane towing. A critical survey of the problem will show why this view has gained ground.

The pupil's preparation for soaring is gliding, but, as a glide involves a constant loss of height, an elevated starting-point is a primary essential. Such points are found in the hills and from the slopes of these gliding is done. The machines are launched from the slope into the air by means of "live catapults" in the form of starting crews, who pull on rubber shock-absorber cords.

This catapult start involves certain educational difficulties, because the principle of all systematic instruction lies in graded progress from simple to difficult tasks. In a catapult start this principle is reversed.

Old, experienced pilots of power-driven machines have told me that every catapult start gives them "a bit of a thrill." This expression was used to me by a professional pilot who had to make catapult starts in power-driven aeroplanes from ships, and a process that provides thrills for a professional pilot is surely a wrong one for pupils who are only just beginning to acquire the art of flight.

The swift start causes such excitement to the beginner (whose nerves are generally in a state of tension at the mere

prospect of flying) that it robs him temporarily of all power of thought. I have noticed the fact that the experienced pilot of a power-driven aeroplane who takes a course of gliding undergoes precisely the same sensations in this respect as the raw novice, and although the dangers attendant on this state of "paralyzation" (as it is sometimes exaggeratedly termed) have been overstated, there is no doubt that they frequently lead to crashes which retard the pupil's instruction, the cause of the mishaps being mainly due to another feature of the "classical school," i.e. the sudden acceleration of the machine. The rubber cable endows it temporarily with power sufficient to sustain in the air a large-sized power-driven aeroplane.

There is no great danger attached to this method, provided that the pupil reacts correctly and keeps his stick in the position indicated by his instructor for the moments of the start. If, however, he fails to do so, the combination of fast speed and the check administered to his thinking powers are likely to place him in a perilous situation because the speed makes the controls so sensitive that the slightest movement will suffice to endanger the glider's stability. Frequently the sudden acceleration causes the pupil to slip on his seat; unconsciously he pulls the stick too far back as his body tilts, and the result is a bad stall. The whole process is purely a matter of reaction to the shock; as he goes over, the pilot involuntarily grasps at the stick to steady himself and so pulls it too far back.

This difficulty soon became apparent to the men who developed the starting methods at present in use, and they tried to obviate them by a compromise. They knew that pupils were likely to endanger their machines by this tendency to stall; accordingly they evolved a machine of a type that would give the minimum reaction to any excessive operation of the controls. This machine was the "Zögling," which possesses inherent stability and under-sized control surfaces; the pupil can therefore commit a very large number of errors without imperilling his machine. As a matter of fact the "Zögling" flies best when it is launched into the air with locked controls—as though it were a model. On account of the numerous crashes likely

to occur, its construction is kept as simple as possible, while for the same reason it is fitted with an open seat, which the pilot may not find exactly comfortable but which will minimize the risk of injury to him from splinters in the case of a crash.

This was the only possibility of solving the many difficult problems arising from the catapult start, but disadvantageous consequences soon manifested themselves. When the pupil overcame the shock of his start after a number of flights and began to react consciously, he found himself compelled to make very pronounced movements of his stick to steer the machine. This was invariably the case when he wanted to put it into a turn, and even more so when he tried to bring it out again. In fact, pilots who had learnt to fly on a "Zögling" acquired a very rough manner of operating the controls, and it was not surprising that students of gliding flight who subsequently changed over to power-driven aircraft fell into their instructors' bad books on account of their tendency to over-control sensitive aeroplanes. This difficulty was overcome by bringing out another type of machine which forced the "Zögling" pupils to acquire a more delicate touch. This was called the "Prüfling," and was later replaced by the improved type known as the "Falke."

Undoubtedly the "Prüfling" succeeded in producing pilots with a more delicate touch, but much time was wasted when the pupil changed over from one machine to the other, while the cost of his education was naturally increased by the expenses involved in the construction and maintenance of both these different types. As a rule, the smaller flying clubs were unable to afford the expenses of a second machine and tried to circumvent the difficulty by remodelling their "Zöglings" in a fashion that would improve them aerodynamically and render them capable of soaring flight. The only result was that their pilots grew rougher than ever on the controls as they gained experience.

The peculiarities of a mountain climate, with its frequent fogs and mists, were further difficulties for the pupils who learnt to fly in mountainous districts. Another cause of trouble was the fact that very few mountains had suitable

slopes for beginners to practise on unless the wind was blowing in one particular direction ; consequently prolonged investigations had to be undertaken all over the country before the clubs discovered favourable flying areas. When they succeeded in doing so, they generally found that the best slopes lay at great distances from the thickly-populated districts containing the towns from which their pupils were recruited. The latter were forced to make long journeys to their schools, with the result that instruction became the privilege of those favoured ones who were in a position to spare the time for it. On an average a pupil needs at least three months' instruction before his training can be said to be complete.

In a mountainous district the pupil finds himself constantly obliged to give a hand in helping to carry the machine from place to place. Undoubtedly he benefits from this manual labour, but at the same time it must be remembered that most of the pupils in a flying school are physically strong specimens and that, after all, the aim of the school is to impart instruction in flying to strong and weak alike. From a practical point of view the more a school can limit its activities to the actual work of flying and the less it has to burden its pupils with irksome but necessary tasks outside this work, the happier will be the results it achieves. There are athletic clubs which will be of better service to those desirous of improving their physique. It is certain that the physical hardships connected with a course of gliding have often deterred individuals who might have developed into skilled pilots.

All these factors combined to produce the result that in Germany (its homeland) soaring flight became a monopoly of the younger generation in general and the students in particular. The university student generally has a long summer vacation in which he can devote three or four months to a complete course of flying, and thus a strong line of demarcation has arisen between gliding and soaring flight, and those other forms of sport which can be pursued in the vicinity of a large town at week-ends or on half-holidays and in the summer evenings of week-days. The inhabitants of flat, lowlying districts are practically excluded

DISTANCE FLIGHT ABOVE CLOUDS

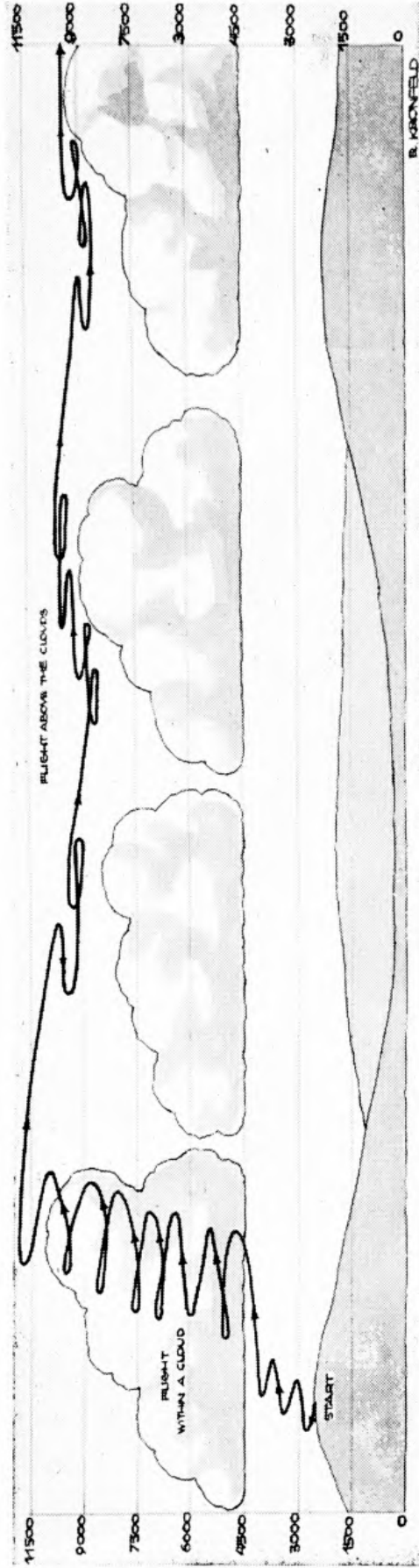

**FLYING ALONG A
THUNDERSTORM FRONT**

- 1. COURSE OF THE STORM FRONT**
- 2. CONSEQUENT COURSE OF FLIGHT**

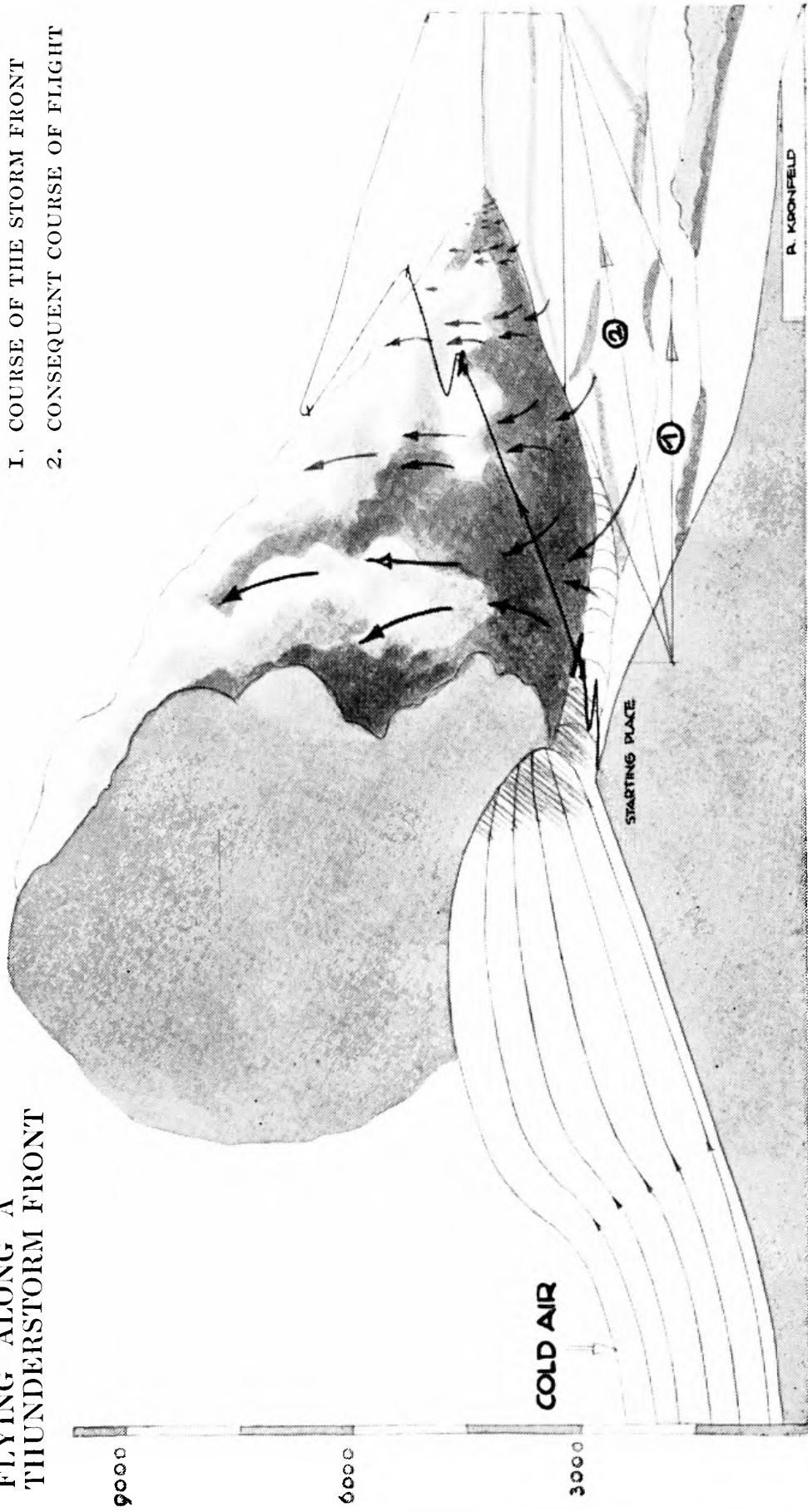

from any participation in soaring flight, as may be seen from the fact that those of them who acquired "Zöglings" and attempted to found schools of gliding in the plains were generally compelled to abandon their efforts.

Soaring flight thus acquired the reputation of being a sport suitable only for mountainous districts where favourable conditions were available. Here we have the great obstacle to its popularization as a national sport, because humanity is mainly settled in the world's plains, where it is difficult to find favourable flying areas within easy reach.

In the infancy of soaring flight there was one strong argument in favour of imparting instruction on the slopes of mountains and high hills. As long as true soaring was only possible in the up-currents found over such slopes, its devotees were forced to limit their activities to the areas containing such slopes, which thus offered the twofold advantage of serving as training grounds for novices and high schools for the further education of advanced pupils. In Germany, moreover, great importance was attached to both the practice and the scientific, theoretical study of true soaring flight; there was therefore no question of endeavouring to popularize courses for instruction in the flat country where only gliding flight was possible.

To America belongs the credit of having been the first country to give practical demonstrations of new methods on a large scale. When the Treaty of Versailles imposed its heavy restrictions upon Germany's power-driven machines, any German who wanted to learn to fly was compelled to put up with the hardships involved in a course of instruction in gliding flight, but when this sport was introduced to the inhabitants of the New World it had to make its way against the competition of the more convenient, though more expensive, engined aeroplanes. But the practical, businesslike Americans were quicker than any other nation to realize the importance of gliding flight as a means of paving the way for a course of instruction in the art of flying power-driven machines. "We must create millions of young people who are permeated with the idea of flight," was the American motto. "Wings for the youth of America!" was the slogan of the friends of soaring flight.

Unfortunately piloting power-driven aircraft is still considered a dangerous occupation ; consequently aeroplane factories are short of the customers they need, while aerial traffic lines cry out for more passengers. But the boy with a " push-bike " is certain to yearn for a motor-cycle, and finally he will invest in a car if his means permit him to do so ; in similar fashion, therefore, the youth who learns to soar will one day want to try a light, power-driven aeroplane, from which he will eventually graduate to all other aircraft. This undoubted fact has induced the Americans to champion the view : " Neither art nor science are the motives of our interest in soaring flight, which we regard primarily as a means of attracting and educating pilots for the power-driven aeroplanes."

Opinions may differ as to the correctness of this point of view, but two advantages have accrued from it. The capital of the aeroplane industries has been brought into soaring flying, while a new method of starting the soaring planes has been found. This is the " towed start " by means of a motor-car.

The Americans wanted to use their gliders and sail-planes at week-ends and in the weekday leisure hours in the same way as they used their power-driven aeroplanes ; they, therefore, promptly tackled the problem of freeing the new sport from its dependence on suitable slopes, the direction of the wind, the large starting crews and the time-factor. They began by using their motor-cars to bring the gliders back to the starting-place after a flight ; then the idea occurred to someone that by employing a motor-car to tow the glider the pilot would be able to dispense with the starting crew. At first the ordinary rubber shock-cable was attached to the motor-car, but later it was replaced by a steel hawser, which caused the machine to rise into the air behind the car like a kite.

Unfortunately a misunderstanding caused the flying enthusiasts in Germany to regard the American towed start as something in the nature of a " stunt " even when it was past the experimental stage and had developed a school of its own. The school methods applied by Professor Franklin met with the greatest success, and certainly set a good

example to follow. The Americans started courses of instruction at their ordinary aerodromes and endeavoured to popularize the movement among the dwellers in the plains without stopping to consider whether they could offer their pupils any opportunities for genuine soaring.

Development on similar lines took place in England, where Lowe-Wylde was the pioneer who swiftly recognized the importance of the towed start as the method for the schools of the future and set about developing new types and methods.

Meanwhile cloud flying was in its heyday in Germany. Thunderstorm flights were frequently carried out, while the thermal soaring by which the pilot utilizes currents of warm air, opened up further fields of activity for motorless flight. From the slopes of the mountains the pilots thus found their way across the plains, taking no heed of the nature of the landscape below them, and experience now seems to show that cloud and thermal soaring are more easily carried out over flat country because a better view of the conditions can be obtained by the pilot and there are less disturbances by other currents.

Eventually a certain need for scientific knowledge induced the Rhön-Rossitten Ges. to experiment with the towed start by means of aeroplanes. Espenlaub was the first to develop the method in Germany, but later Raab, the "stunt" pilot, took it up and used it for exhibition purposes at aviation meetings. In America many pilots began to exploit the new method as a means of carrying out sporting feats, the greatest achievement in this direction being the trans-continental towed flight which Hawks accomplished on a glider specially constructed for the purpose by Professor Franklin.

It was found possible to employ soaring machines equipped with instruments recording temperature, moisture, and pressure, to carry out meteorological flights. The machine was simply towed by an aeroplane to an area where interesting currents were to be found such as those in clouds or in the thermal currents of a pronounced nature which are located over towns. This method made it easier to choose and investigate certain weather and cloud

conditions, and much was done to simplify the art of cloud flying.

Thus we see that systematic schooling-methods grew up in England and America for the towed start by means of the motor-car, while Germany used the aeroplane for the same purpose. In the homeland of soaring flight there were at first only two experts who tried to improve on the methods in use for the towed start by means of the motor-car. One of these was Wolf Hirth, who had returned home after a series of flights in America, where he had studied the method, while the other was the author of this book who had also studied the technique of the American towed start thoroughly and learnt to recognize its value for Germany after he had tested it practically in England.

THE AUTO TOWED START

Numerous experiments were made to test the value of the motor-car for starting purposes, and it was not long before a method was discovered which proved capable of universal application. This method is worthy of a detailed description.

For an auto towed start three primary factors are essential—the motor-car, the cable, and the glider. There are, of course, some other few necessary accessories.

The motor-car must naturally be sufficiently powerful. If an ordinary touring car is to be used continually for this work, it should be one of the $2\frac{1}{2}$ to 3-litre class and one whose upkeep is not too expensive. If a racing car is available, the capacity of its cylinders may be even smaller. On the other hand, a highly-powered car is often a source of danger, as it is liable to place too great a strain on the glider. As a general rule the car should be such that, from a standing start, it may be speeded up steadily to from thirty to forty miles an hour. If a glider equipped with wheels is used, the car-driver can change gear, but experience has shown that it is better, if possible, to avoid any sudden variations of speed. The primary need is to avoid any strain that might break the cable or its connection



62. ESPENLAUB'S GLIDER THAT WAS TOWED BY A MOTOR-PLANE, 1927

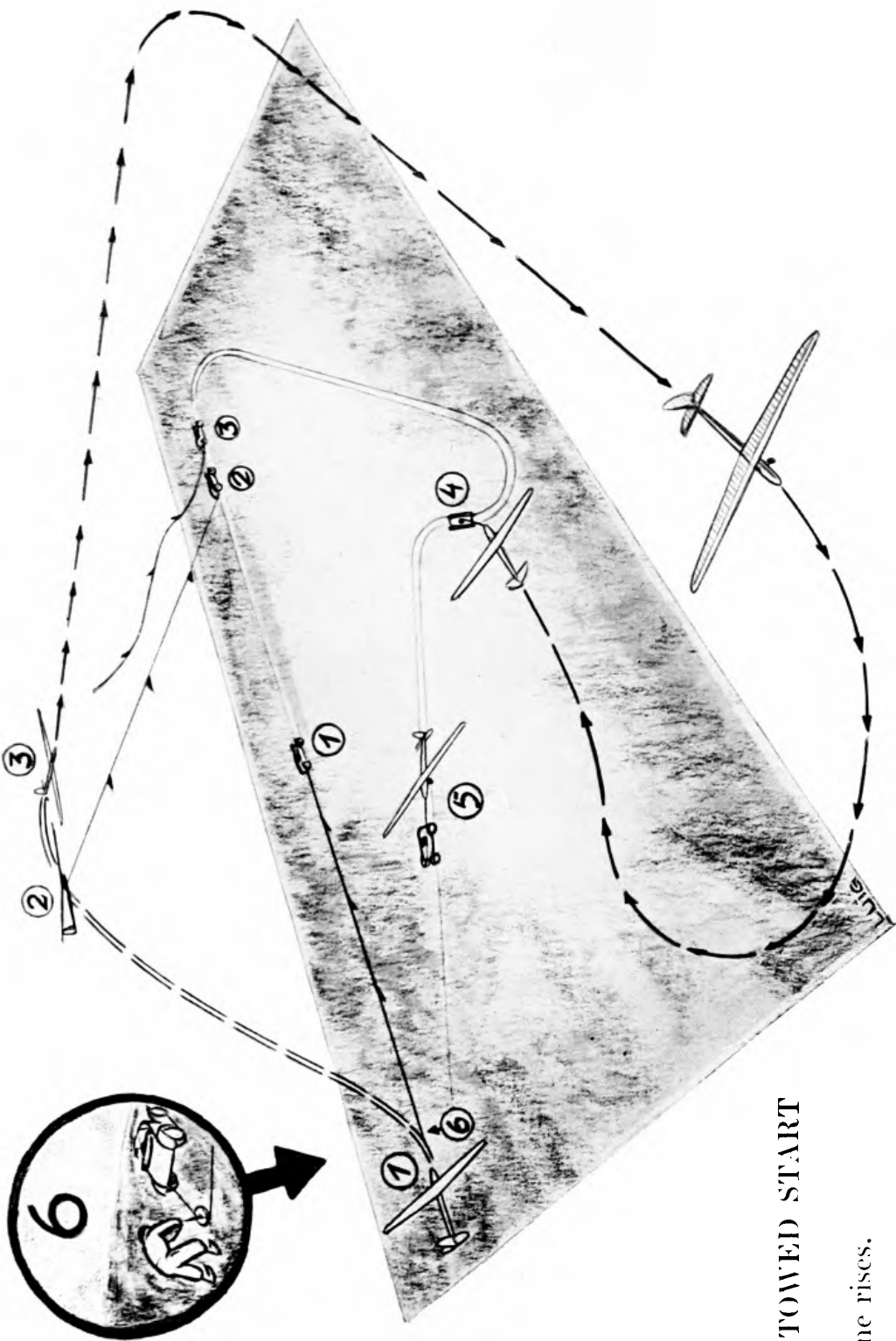

63. THE AUTO TOWED START

1. The start.
2. Soaring plane rises.
3. Casting off.
4. Landing.
5. Car tows the plane back to starting place.
6. Winding in the cable prior to fresh start.

to the glider ; the clutch must therefore be let in gently and the motor-car accelerated evenly without jerking.

The springs of the car must be of a type which will permit it to be driven at from thirty to forty miles an hour over the uneven ground as found on some aerodromes. The less the car bumps under these conditions, the better the results will be. Weight is also a matter of importance ; if the car is too heavy, it takes too long to accelerate, and consequently the glider will not rise easily. On the other hand a very light car is liable to bump too much. On the whole a medium-weight car with a good ground clearance is the right type.

It is wise to turn a deaf ear to tales of the good behaviour of heavy cars on rough ground. A heavy car may seem to take the inequalities of the ground well, but in reality it can only do so at the expense of its springs, axle and differential. Such cars are liable to break down suddenly when employed on this kind of work, in which case the result is usually a heavy bill for repairs.

An open car is naturally preferable to a closed one on account of the better view of the operations which it affords ; likewise it facilitates the attachment of the cable. The simplest place to fasten the latter would be either the rear bumper-bar or the luggage carrier, but in this case the simplest is not always the best. Any car traversing the surface of an aerodrome at a high speed is bound to meet with some bad bumps ; should one of these occur at the moment when the glider is flying vertically above the car, the shock will be communicated to it through the taut cable. The result will be an excessive strain on the machine which may easily lead to the breakage of a wing, so it is therefore a far better plan to attach the cable to the centre of gyration of the car, which is about the back of the driver's seat ; on the other hand, it does not matter whether the cable is fixed on the right or the left of the driver.

A closed car can be used if the attachment is made at one side of the car at a spot equidistant from the front and back axles, but the instructor will find it very difficult to keep an eye on the machine or the pupil in it. If the use of a closed car is inevitable, it is best to have the observation done by

a man standing on the step or sitting on the back seat and looking out through the window at the back. As both these methods are inconvenient, a good plan is to attach a trailer to the car. In this the observer sits on a bicycle saddle, with his back to the driver ; the quick-release to which the cable is fastened is then fixed to the trailer. This arrangement also permits the observer to carry a drum in his trailer which he can brake if necessary as the cable runs out, and upon which he can wind up the cable after use. A similar drum arrangement can also be used with an open car, where it must be placed at the centre of gyration.

For reasons of safety the car must have a quick-release as well as the glider ; the great disadvantage of the drum being that it prevents immediate release in cases of emergency. This defect, however, can be remedied by fastening the end of the cable on the drum by means of a peg, from which it will be released the moment its full length runs out ; this eliminates all possibility of trouble if the quick-release on the glider itself fails to loose its end of the cable.

As even such a release must take a certain amount of time to operate and there is always the possibility of the winch jamming or the cable becoming tangled, it is advisable to have some means of cutting the cable in case of emergency. The best device is an ordinary pair of shears or wire-cutters, one handle of which is affixed to the winch in a way that allows the outgoing cable a free passage between the open blades, while the observer has only to press the other one if he wants to sever the connection.

On grounds of safety some experts recommend the use of a hempen rope for machines carrying pupils, because in case of emergency it breaks more easily than a steel cable. But the latter stands wear and tear better than the former, while provided its dimensions are not too great, or an artificial flaw is created, it will break as easily as a rope in case of need. I therefore prefer the steel cable, as it is possible to use the same form of cable for both novices and advanced pupils. A third alternative is steel wire, which finds favour on account of its cheapness, but it is awkward material to handle and does not stand strains too well. After all, the towing cable need not be made of the expensive

material which is used for the glider's control cables ; the latter, of course, have to stand the wear and tear of constant friction when operating on their pulleys, so that they must necessarily be made of the finest and most flexible material. The towing cable, however, is not subjected to such strains.

We can therefore be satisfied with a cable composed of fewer but stronger strands, which will be fairly cheap to purchase. This cable should be impregnated or coated with a strong varnish in order to prevent moisture or grains of sand collecting between the strands, but no preparation containing any kind of acid must be used for this purpose.

The life of a towing rope can be considerably lengthened if a spring connection is used with it. Various devices were tried for this purpose, but eventually the simplest of them found most favour.

This is a double piece of ordinary rubber shock cord, three to six feet long. This is affixed to one end (or, better still, to both ends) of the towing-cable, but in either case a check cable must span the rubber cord so that if this latter breaks the glider will not suddenly be freed. If only one of these " springs " is used, it must naturally be located at the motor-car end of the cable, because the other end trails on the ground when the pilot has released it, with consequent wear and tear on the rubber itself as well as on the splicing.

It goes without saying that a towing-rope rendered elastic in this fashion will do much to save the machine from wear and tear as well as prevent accidents in the case of a sudden strain. There is, of course, no technical reason why an all-rubber towing-cable should not be used, but as the same effect of resilience can be induced by the method described above, the cost of a rubber cable and its short life are decisive factors against its use. Moreover, a rubber cable risks the accumulation of uncontrollable energies and may cause undesirable oscillations.

Cables can easily be wound up and stowed away when not in use ; dividing, by coloured tags, into sections of from thirty to sixty feet in length is also useful, so that the observer can easily check the length of line he is paying out.

Any type of glider can be used for these towed starts,

provided that its construction is strong enough to stand the strain and its speed approximates to the normal speed of the motor-car towing it. The heavier type of machine naturally gathers speed more slowly and requires a longer run before it can be released. Gliders of the type known as the light-wind sailplanes can be towed by smaller cars, but care must be taken not to put too much strain on their light frames. The "Zögling" was never designed for such purposes, but machines such as the "Prüfling" and the "Falke," which are built with normal fuselages, have been found quite adaptable to it. The best type is, however, the "Utility Glider," specially designed by the brothers Franklin for towed starts. This fulfils one of the most important demands made on the types used for towed starts in that it is highly sensitive and responds readily to all its controls.

Such machines must also be designed so that they readily assume their proper flying angle and can quickly rise from the ground. Most soaring gliders would be found wanting in this respect.

The towed machine must likewise "taxi" well. Judging by the experience of instructors, the best type of machine for such purposes runs on a central wheel and answers readily to all controls when moving along the ground at a pace less than its flying speed. The wheel or wheels must not be set too far below the fuselage, otherwise the machine is likely to capsize, but perhaps a machine provided with a wheel running in a divided skid is the best solution of this problem. It is also advisable to have a wheel brake that will prevent the machine running too far and enable it to be landed either with or against the slope in hilly country, in the latter case it is necessary to guard against the glider running backwards after it has landed, and for this a wheel brake is most useful.

A machine with an enclosed cockpit gives the pupil a greater sense of security and enables him to accustom himself from the beginning to the types which he will afterwards be expected to fly. A machine employed for instructional purposes should also be built more solidly than one intended for soaring only; it thus gains in strength, while the extra

weight is easily counterbalanced by the power of the motor-car. The pilot's seat should be located in a position which enables him to have a vertical view of what is happening directly below him, so that he can keep an eye on the car and the cable at the moment when the machine rises to its maximum captive height.

Another important factor is the fitting of the quick-release on the glider itself. Many mistakes have been made in this respect. If large altitudes are to be reached the release must be placed in a position that permits the line of the cable to pass through the centre of gravity of the glider. This is the only way to save the machine from those strains which are bound to occur when the cable is attached to the machine's nose. The pull on the machine then produces a continual forward dip, which the pilot constantly endeavours to correct by pulling his stick backwards. It is technically difficult to install the quick-release actually on the centre of gravity, although that would be best. If the glider is to attain its maximum height after the pilot has cast off the cable (as, for instance, in competitions), the best position can only be found by drawing through the centre of gravity in the direction of the nose a line of ten degrees out of the vertical. The point where this line intersects the floor of the cockpit or the skid is the correct position for the hook.

This is, however, not a practical position for the quick-releases of gliders used for instructional purposes. The further back the quick-release is placed, the greater will be the machine's inclination when it is taxiing. For school purposes it is therefore advisable to put the quick-release in a position where it will allow the line of the cable an inclination of about thirty degrees to the vertical.

When a machine receives its start from the towing power of a car or an aeroplane, it is a matter of vital necessity that the mechanism shall be in good working order, so that the contact may be broken at any moment from either end if occasion arises. It is obvious that the failure of the release would have disastrous effects, but in order to allay any fears the timid may have I herewith take this opportunity to assure my readers that the cable, which is usually not over

strong can generally be broken in an emergency by an extra heavy pull from the glider.

On the other hand, I have also known a case where the mechanism failed to operate when the pilot put his glider into a turn. The cable prevented him from completing his turn, and the consequence was a sideslip. There are many kinds of quick-releases which behave splendidly as long as the machine moves forward in a straight line, but, in my opinion, the least that can be expected of such mechanisms is that they should permit the pilot to cast off the cable from any position into which he may put his machine. It sometimes occurs that the glider forges ahead of the car, so that the cable leads backwards from it and in front of the towing-car. This angle is the very reverse of the correct one, and in such cases the pilot should be able to cast off as quickly and easily as possible.

This desirable consummation has been achieved by two different devices. In one of them the catch of the quick-release is so constructed that it can be pulled open in any direction ; in the other the ring at the end of the cable is pressed against a spring with a strong outward action when it is put into the quick-release ; when the latter is opened the ring is then bound to be forced out.

The quick-release should be easy to operate from the pilot's seat. Good results have been achieved by means of a small handle affixed to the control column in a fashion similar to that employed for the brakes of motor-cycles. The pilot can then operate the mechanism without undue fumbling. The connection between this handle and the quick-release itself is best effected by a Bowden wire.

Mention must be made of another small accessory. The normal practice in the ordinary towing schools is to allow the cable to trail along the ground after the pilot has cast it off ; the car then proceeds to the position where the glider is expected to land, and tows it back to the starting point. The driver's next problem is to pull the cable round until it forms a line against the direction of the wind ; this is effected by means of a steel tube with a pointed end, on which is mounted a revolving pulley. The point of this instrument is forced into the ground, and the cable is

allowed to run round the pulley. The car drives round until it has drawn the rope into a faultless straight line ; then, as soon as the free end of the cable has been hooked on to the machine, everything is ready for a fresh start.

Finally I would emphasize the advantages of telephonic communication between the pilot of the glider and the driver of the towing-car. This is a safety device which eliminates many accidents.

The pilot can warn the driver of the car to go faster or slower ; he can, in fact, regulate the pace of the car according to the velocity of the wind he finds aloft. The telephone line can be inserted in the cable and made to fit into a plug in the soaring-plane. The great advantage of this is that both the pilot and the driver are warned by the severance of telephonic communication that the cable has been cast off. A telephone also enables an instructor to give directions to his pupil while the latter's machine is rising.

SOME RULES FOR INSTRUCTION IN TOWED FLIGHT

In towed starts as in other branches of soaring flight the instructor should take the precaution of letting his pupil advance gradually from the easy to the hard tasks.

The first exercise for the pupil is to learn to manage his machine during its preliminary taxiing behind the car. At this initial stage the instructor should allow only a short length of cable between the car and the glider so that he (from his position in the car) can keep a closer eye on his pupil. The short length will also prevent any danger of the cable catching on the ground when the glider swings out sideways. At first the car should only be driven at a speed less than the glider's minimum flying speed ; and the pupil should be ready to operate the quick-release immediately. If the plane has been properly built, it will even at this speed answer to all the controls.

The pupil must first learn how to manage his rudder and endeavour to keep his glider directly behind the car. He then masters the functions of the ailerons, after which he may practise lifting the tail gently into flying position.

The first taxiing exercises ought to take place on windless days in order to avoid any danger of a sudden gust lifting the glider from the ground and to permit the instructor to drive across the aerodrome as he will, thus eliminating much waste of time.

It is advisable to put the pupil through a course of at least ten taxiing exercises, so as to make quite sure that he learns how to use the controls ; the instructor may then let him undertake ten short flights at low altitudes. In these the pupil is told to lift up the tail, after the usual run along the ground, and then take off gently. As soon as he finds that he is in the air, he must gently land again. This process of alternate taxiing, rising and landing must be repeated several times in order to instil into the pupil a sense of the motions of taking off, moving through the air and coming down.

When the pupil is proficient in these exercises, his next task is to fly at a height of about three to six feet while following the car right across the flying-ground. The length of the cable has meanwhile been gradually increased, and for these captive flights it should be about three hundred feet long.

The novice must be under strict discipline. The great advantage of the towed start is that it enables the instructor to exercise complete control over his pupil at any given moment. If, for instance, a false sense of ambition inspires the latter to climb higher than his state of proficiency warrants, the instructor can sever the connection at his end as soon as he sees that the stick is being pulled back too much, whereupon the glider is bound to come down before it can reach a dangerous height. Such disciplinary measures will teach the pupil to obey all orders.

The pupil's next lesson deals with the operation of the quick-release. He receives instructions to rise to a height of fifteen feet or so, note whether his machine is in a correct flying position and then cast off and come down in a glide. During the whole course of instruction it is important to aim at preventing the pupil stalling while climbing, his aim should be to keep it in a position which will permit him to commence his glide the moment he has cast off. This

exercise will have to be repeated from six to ten times before the pupil can perform it with complete safety.

When he is perfect in it, there is no reason why he should not be allowed to rise somewhat higher (to about fifty feet, let us say) and learn how to climb a little faster, although the instructor must insist upon him pushing the stick forward and putting the machine into a glide as soon as he has released the cable. After five such flights the pupil may be allowed to rise to heights varying between one hundred and fifty and two hundred feet.

Then come the turns. The pupil is told to put the machine into a gentle turn, paying particular heed to the action of his rudder and ailerons. Then come the steeper turns, but the instructor must impress upon his pupil the dangers of attempting to turn when only a short distance above the ground or making a turn before he has flown some distance on the straight. Then come five further flights on a three hundred and sixty feet length of cable, during which the pupil should be able to practise S turns when he has cast off.

The next stage admits of a six-hundred feet length of cable, which gives the pupil his first taste of the heights. Here the instructor must take care that his charge does not climb too fast and also make sure that he casts off at the right moment. The more difficult exercises must, of course, be practised only in calm weather, but it is a good plan to let the pupil repeat the easier ones on windy days. When, for instance, the glider has reached a height of about one hundred and fifty feet, the pupil can try taxiing in a wind, and, if he is proficient in S turns on a windless day, he can be allowed to learn the art of straight flying in strong winds or gusts.

Six hundred feet of cable should easily suffice for flights of one to two minutes' duration, but only after a thorough course of training should the pupil be permitted to practise turns of three hundred and sixty degrees before landing. A more advanced pupil can then learn to handle the machine when the car tows it in various directions and practise turns around a mark on the ground. Finally a landing Tee is laid out, and the pupil learns to come down on it.

Above all, the instructor must see to it that his pupil ascends calmly and without fluster, keeping a careful eye on the motor-car's movements all the time he is rising. The pupil must be cautioned against turning back unless he is flying at a sufficient height. "Keep your eye on the cable" is a golden rule, and it is a good plan too to mark its length with flags placed at various intervals.

In this, as in other forms of flight, a slow, careful and graded course of instruction is a surer way to true success than a quick, hustling method can ever be.

WINDLASS STARTS

We now pass on to a variation of the towed start by means of a stationary windlass, which is placed at one end of a small aerodrome or in the middle of a large one. The cable is then attached to a drum which must be of dimensions that will permit the winding process to take place at a speed equivalent to the machine's normal flying speed. By these means it is possible to achieve the same results as with an auto towed start.

If only one car is available, it is possible to lock three of its wheels and jack up the fourth. The cable then operates on a drum made fast to the hub, but it must not be forgotten that as the car's differential is now inoperative, the one wheel will revolve at twice the pace of two wheels running on the ground. Failure to observe this precaution once resulted in a fatal accident.

Another variation is the motor-windlass, which can be made out of an old car by affixing a drum to the engine or the Carden shaft. In this case it is advisable to place the windlass close to the starting-place, so that the instructor is in a good position to watch his pupil's actions; the cable is then carried across to the other end of the ground, where it passes round a stationary pulley. A vital necessity for this kind of start is a cutting implement, through the open blades of which the cable must pass, so that the instructor can sever the connection at any given moment.

The pupil must not forget that this form of start limits

the height to which he can rise, for as soon as his machine comes over the windlass it will be pulled vertically downwards. He is therefore compelled to cast off sooner than in an auto towed start.

Very much greater lengths of cable are required. Three thousand feet is quite a normal length for the cables employed in this start. I recommend the instructor to affix a bright-coloured flag to the cable at a suitable spot ; as soon as the pupil sees this flag appear on the pulley or the windlass, he will then know that the right moment has come for him to cast off. It is also advisable to have another man on the ground with a flag which he can wave as a signal to the pilot to free himself from the cable.

The great advantage of this method over the others is the fact that it saves much wear and tear on the car, especially if the latter has to traverse rough, uneven ground in the course of the start. Although most differentials are not built to stand long strains, they are not likely to suffer much damage as the time required for the take-off only is from one to two minutes, after which the engine and differential have a long rest. Experience has shown that no evil consequences need be expected for the car. Another advantage is the elimination of damage to the aerodrome which is bound to suffer if constantly traversed by heavy vehicles.

A further advantage of the windlass is the even pace at which it tows the machine. The engine is spared the extra burden of propelling the car's weight ; consequently the machine begins to rise after a very short run. The start can therefore be given with an engine of far less power than that needed for an auto towed start. Moreover, this method can be used on rough ground which a car would be unable to traverse.

The size of the field does not matter greatly for so much space is not lost as when using a car with a long cable. On large aerodromes it is quite easy to sink a permanent windlass somewhere in the middle of the ground, in which case the cable is directed upwards by means of a swivelling guiding-pulley.

Against these several advantages we must take into

consideration the drawback that a special car is generally needed to bring the glider back to its starting-place after it has landed. The use of a second drum and cable will obviate this, but much valuable time is generally wasted in getting the cable into position. Circumstances will have to dictate whether this method or any other is to be used to bring the glider back, but it should not be too hard to weigh up the pros and cons and reach a practical solution of the difficulty.

AEROPLANE TOWING

(I)

THE AEROPLANE

In practice, aeroplane-towing is feasible for any sailplane possessing effective controls and built strong enough to stand the strain, provided that the aeroplane can be flown at a speed not much greater than the normal speed of the machine it is towing.

To each make of gliding or soaring plane must therefore be assigned a particular type of towing-aeroplane, while for reasons of safety, care must be taken to ensure that the weight of the tower does not too greatly exceed that of the towed. A towed machine makes its best flights when the weights of both are approximately equal, but it must be remembered that in gusty air the power-driven machine's speed will be greatly reduced by an over-severe pull on the cable. Its pilot can do nothing to remedy this state of affairs. Another indispensable safety condition requires that the power-driven machine shall answer readily to its controls, even when near the stalling point ; if the machine has any tendency to drop its nose or a wing, there is bound to be an accident. But the average light aeroplane is very reliable, as is also the heavier old-fashioned school machine with low wing loading.

The cable must be affixed to the towing machine in a way that will prevent it from becoming entangled with the controls or any important parts of either machine, whatever

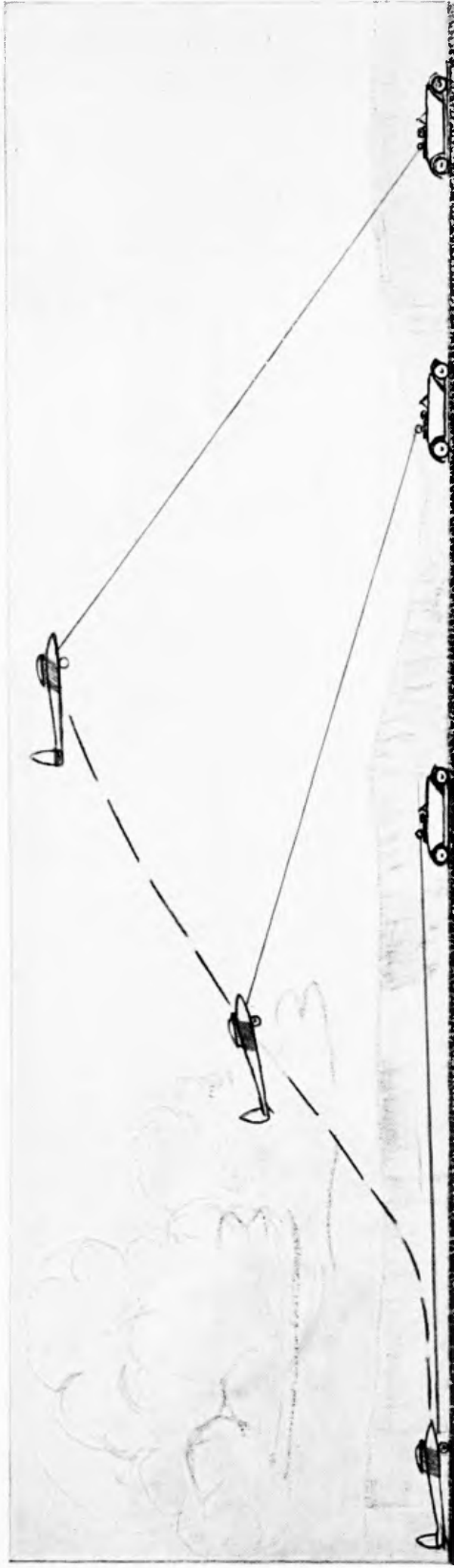

64. NORMAL AUTO TOWED START

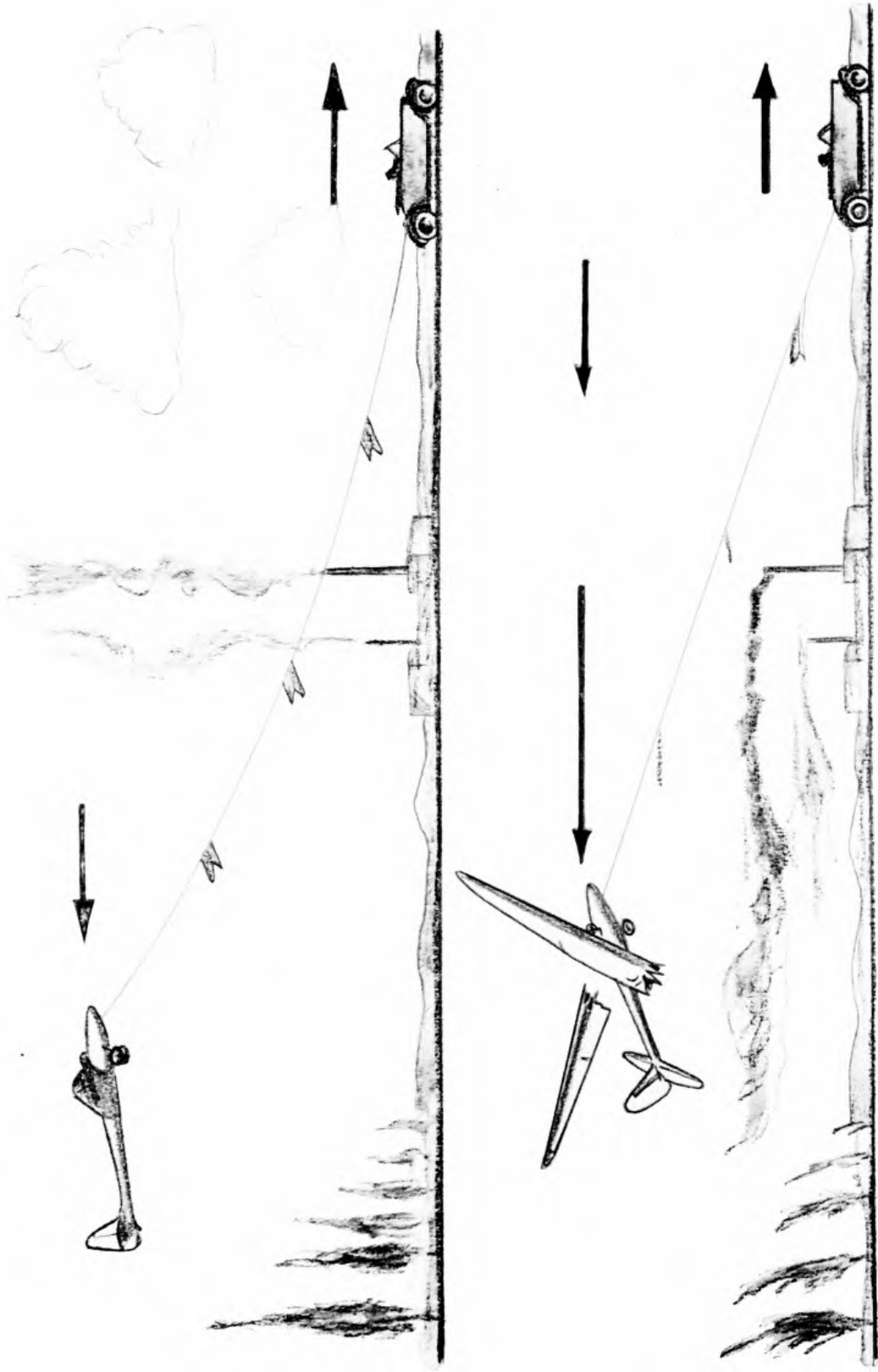

[Upper] AUTO TOWED START IN DEAD CALM.

[Lower] AUTO TOWED START IN GALE. THE SOARING PLANE IS ENDANGERED BY EXCESSIVE STRAIN. THE STRONGER THE WIND, THE SLOWER MUST BE THE CAR'S SPEED

may be their positions. The ideal arrangement is for the cable to be carried past the tail surfaces in a tube so placed that the prolongation of the cable's line in normal flight runs through the centre of gravity of the power-driven aeroplane. The quick-release can also be placed behind the tail surfaces, but here again the line of the cable must pass through the centre of gravity. Moreover, great care must be taken to prevent the cable fouling the tail surfaces when cast off.

If these two requirements are to be met fully, it would seem necessary for the power-driven machine to be equipped with a more or less complicated towing apparatus. But here theory and practice are at variance, for experience has shown that fairly simple devices will give complete satisfaction. For beginners a fool-proof apparatus is undoubtedly an essential, but simpler mechanisms will suffice if the pilots of the power-driven machine and the soaring plane know their business and take care to keep one behind the other in a fairly straight line. In America it is often the practice to place the quick-release somewhere on the power-driven aeroplane's skid. This is a most precarious position, as the cable is liable to foul the tail surfaces if the glider rises high above its tower. The danger can, however, be minimized by prolonging the skid sufficiently to ensure free passage for the cable, no matter what position the soaring plane may assume. If it is impossible to ensure this clearance by such means, the difficulty can be circumvented by affixing a short length of steel tubing, secured by two clips, which will project from under the rudder. The hook is then attached to this projection.

Aeroplanes destined to be used permanently for towing should carry drums on which the cable can be wound. The advantage of this is that the length of the cable between the two machines can be varied for starting to suit the size of the aerodrome, while the cable can also be paid out during the flight. The shorter the cable, the more difficult will be the work while the two machines are connected in the air, but on the other hand it is impossible to use a long cable for a start on a small aerodrome.

Safety measures and devices must not be neglected. As a fairly short length of cable is generally the rule for

aeroplane towed flights, the drum carried in the aeroplane should be provided with a peg off which the cable will slip as soon as it has run out to its full length. As in the case of towed starts by motor-car, the cable should be rendered resilient by attaching a piece of rubber shock-cord at one or both ends, while it is always advisable to affix flags to the cable in order to render its position visible during a flight. Too much stress cannot be laid on the advantage of telephonic communication between the two pilots.

(2)

THE TOWED GLIDER

If gusts should lift the glider high above the aeroplane towing it, the former is likely to find itself carrying some portion of the latter's weight. This places too great a strain on the glider and may easily lead to a broken wing. Another danger factor is an excessive towing speed.

Hence it is our endeavour to reach a compromise between safety measures and flying efficiency. As, in my opinion, the towed flight is more suitable for instructional purposes than for cross-country flights, it seems to me unwise to deviate greatly from the strength and weight found necessary for normal sailplanes, which should, therefore, be towed only by aeroplanes of slow speed and light engine-power. For special "stunts" or for long overland flights gliders with special modifications must be used, but it must be remembered that all such are generally made at the expense of performance in free gliding flight. The demands, with regard to the position for the quick-release, the view for the pilot and controllability, are more or less similar to those desirable for towed starts by cars. The cable should be about four hundred and fifty to six hundred feet long and from one-eighth to seven-thirty-seconds of an inch in diameter.

The best method of imparting instruction in aeroplane towed flight is in conjunction with a course of car towed starts. In each case the same principles apply to the start.

While the power-driven aircraft is still taxiing, the glider rises about thirty feet above it, but this height must not be increased. When both machines are in the air, the pilot of the glider must endeavour to keep more or less the same height and distance above and behind his tower ; this is a feat which should cause little difficulty to a well-trained pupil. Preliminary training should include several short flights in which the pupil tries to maintain his height of thirty feet above his towing machine and memorizes the angle of the cable. As long as he maintains this angle, he may be sure that he is flying correctly. He must keep height and distance while both machines are rising ; then the power-driven machine goes into a wide turn and heads for the aerodrome, while the other casts off and lands after a glide.

The first flight should be a short one, so that the instructor may say whether the position with regard to the towing-machine were correct. Telephonic communication between the two machines makes for a better understanding between instructor and pupil because the former can correct the latter's errors during the flight itself. It goes without saying that the initial flights should only take place on windless days or in light, steady, gust-free breezes.

The glider pilot can render the power-driven machine's start easier by rising higher as soon as his plane leaves the ground and then easing the stick forward ; he thus frees the towing machine from his weight and enables it to get off the ground more quickly. As the normal flying speed of a power-driven aeroplane is greater than that of a glider, the increase of pace imparted to the latter machine by the impetus of the tow will render its controls more sensitive—especially the elevator. The pilot therefore must learn to accustom himself to this increase of sensitiveness.

On days of wind and gusts a towed flight becomes a difficult matter, and under certain circumstances it may prove one of the hardest flying feats to perform. When the sky is full of cumulus clouds, ticklish situations often arise because one machine gets into an up-current while the other is still flying in a downdraught, or vice versa. It is essential to impress upon the pupil's mind that whenever he feels the

cable to be subjected to too great a strain, he must cast loose before he gets into worse trouble.

The best method of flight is for the power-driven aeroplane to proceed at an even speed while the pilot of the towed machine tries to correct any deviations from the direct line of flight. If both pilots attempt to make the corrections, the result will probably be a series of oscillations, but if upward gusts lift the power-driven aeroplane to a height above the glider, the pilot of the former must throttle his engine and dive until he comes down to the latter's level.

If a conspicuous flag is attached to the middle of the cable's length, the towed pilot can judge whether his position is correct by noting its slope below him. In gusty weather the cable will often be suddenly drawn taut, but by keeping his eye on the flag all the time he will be able to ease the strain at the critical moment by pushing his machine down slightly and thus relieving the tension. He can also avoid sudden jerks on the cable by flying slightly to one side of his tower, so that he can watch his movements and act accordingly. When the strain becomes too great, he must allow his machine to oscillate in arcs until he can resume his original position slightly to one side of his leader. Thus he creates a kind of elasticity which has a damping effect on the cable's motions and helps to keep it at an even tension.

The pilot towed by an aeroplane will require some considerable practice before he makes his turns correctly. Sharp turns are unnecessary, and the best position in any turn is on the outside of the aeroplane. If the glider pilot gets on the inside of the towing-machine during a turn, the cable is bound to slacken ; he then loses height and is liable to drop below his leader. But if he keeps on the outside of the towing-machine, so that he has to cover the greater amount of space by flying in a wider radius, he will keep the rope taut and consequently rise. In this way he can regulate his height above the towing-machine during a turn.

If during a cross-country flight the power-driven aeroplane is compelled to lose height, its pilot throttles down his engine, and dives gently, the glider meanwhile diving



66. A STATIONARY MOTOR-WINDLASS

**AEROPLANE TOW
START NO. 1.**

**CORRECT POSITIONS :
THE TWO MACHINES
ARE FLYING LEVEL**

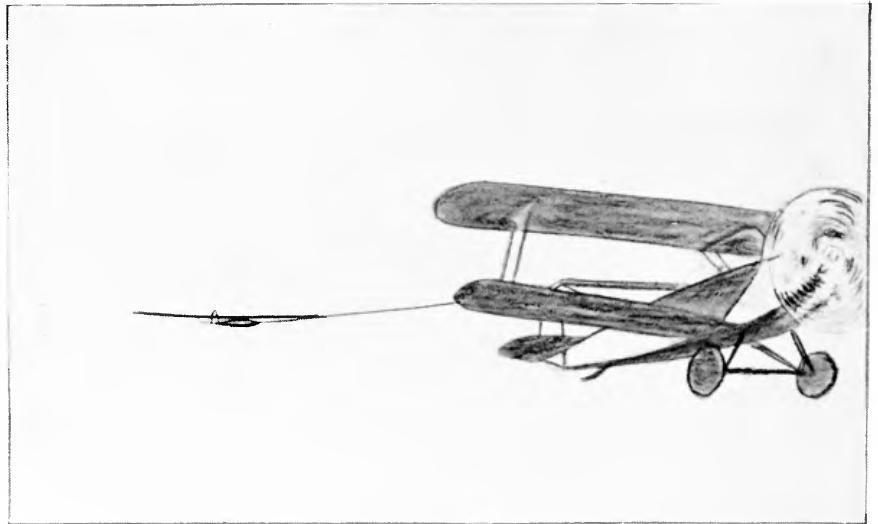

**AEROPLANE TOW
START NO. 2.**

**THE SOARING PLANE
IS FLYING TOO HIGH
AND THEREFORE EN-
DANGERED BY THE EX-
CESSIVE STRAIN ON IT**

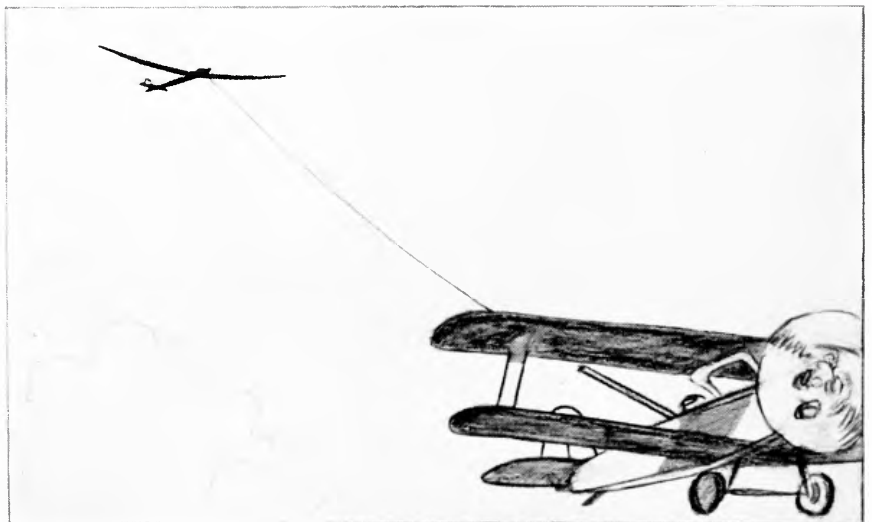

**AEROPLANE TOW
START NO. 3.**

**THE SOARING PLANE
IS TOO LOW. THE
AEROPLANE IS THERE-
FORE IN DANGER OF
STALLING THROUGH
EXCESSIVE STRAIN ON
ITS FUSELAGE.**

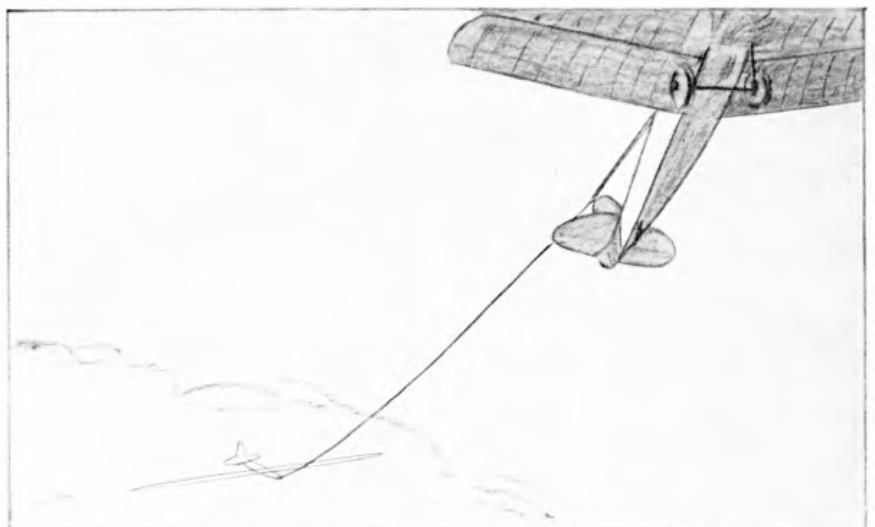

down at a speed equal to his own. The best procedure is then for the two machines to fly close to one another, letting the cable hang down in a loop between them. The two pilots can then watch the cable and each other. Should the aeroplane pilot even out and resume level flight, the pilot in the glider must fly in curves, as already described until he can resume a normal position.

As soon as the towed pilot casts off, his machine loses speed, because during the period of towing he has been flying at a pace considerably faster than his normal one. He therefore has no need to push the stick down to retain speed. The two pilots must keep their eyes on the cable all the time so as to be ready for emergencies in case it breaks, or one or other of them is compelled to sever the connection. When flying low or over the aerodrome, pilots must remember that they may have some three hundred feet of cable hanging down below their machines, which is liable to foul houses, trees or high-tension wires. It is better to cast the cable off in such cases and risk losing it altogether rather than keep it in a situation which might easily lead to a crash.

The aeroplane towed start has the same advantages as the car towed start. It renders any special terrain unnecessary, as any aerodrome or meadow can be used for such starts. It also renders pilots independent of the atmospheric disturbances prevalent in mountainous country and saves much waste of time. Flights can be started and carried out in a few minutes ; height is gained as easily as in the car towed start, but such height can be increased *ad infinitum*, while the soarer can sever the connection at any altitude he pleases.

Another advantage of the aeroplane towed start is the fact that it does not involve the co-operation of a large number of persons. If the first take-off fails, there is no obstacle in the way of further attempts. As such flights can take place in practically any weather, it is a regular, recognized method of teaching cloud and thunderstorm soaring. The pupil is simply towed up to the cloud area, where he casts off and then attempts to soar. Should he fail to maintain himself in the air, he has only to land and wait for his instructor to tow him up again. Moreover, the aeroplane

can tow any number of sailplanes into fields of favourable upwind in an incredibly short space of time, thus placing them in a position to soar at heights which it would have taken them hours to reach by their own efforts. The aeroplane tow also represents a direct economy for the pupils and instructors of gliding schools as a course of instruction can be given in one-half or even one-third the number of lessons required by the old methods. Finally remember the fact that the soaring-pilot will find it far easier to land on an aerodrome than in the mountainous country frequented by the devotees of the older methods. The risks of damaging the machine on landing are therefore considerably decreased.

The numerous advantages to be found in car and aeroplane towing have won for these methods a host of friends in an incredibly short space of time. There is hardly a doubt that they will become even more popular in future years.

Gliders of the years to come will acquire the habit of taking off from aerodromes, where the beginners will receive their first lessons from instructors in cars. The car towed start will also be used for the second stage of instruction, after which the advanced pupil will be carried aloft to the clouds by an aeroplane to execute long flights by the aid of thermal currents or the cold fronts of thunderstorms. Aeroplane towing has rendered possible the utilization of the warm currents to be found over large towns and will inspire every member of the younger generation with a desire to be seen soaring above his native town in a sailplane.

THE CONSTRUCTION OF GLIDING AND SOARING PLANES

AS we have seen from the history of soaring flight and of soaring competitions, four things are needed for successful flying : (1) a suitable flying-ground ; (2) pilots with the necessary flying skill ; (3) favourable weather ; (4) good flying machines. It would be difficult to say which of these factors is of most consequence, but we assuredly must not underrate the importance of the machines.

By the instruction of our pupils and the feats of our experts certain standards have gradually been evolved. Similar standards apply to our machines ; again and again we have seen how futile it is for the novice desirous of learning to soar to think that he must invent some new kind of glider. In the last century when no such thing as a motor-car was to be had, he who wanted one had to build it for himself ; to do so to-day would be nonsense. So it is in gliding and soaring, and the beginner of to-day will do best to procure a finished machine of a well-tested school type. He who takes pleasure in building his own machine or is obliged to do so for reasons of economy should obtain the plans of such a model and construct his glider according to them in every detail, trusting in the many years' experience of well-known designers and not attempting to improve such machines himself.

It is possible to classify the great family of gliders and sailplanes in various ways. They might be grouped according to differences in construction, the purposes for which they are intended, or their flying capacities. The man with practical knowledge will probably prefer to class them as : school, training, and high-performance types.

The school type is a glider, because gliding is the first step towards soaring, and its most usual form is the

open girder or primary type, the pilot sitting on an open seat, in front. But, on historical grounds, the "Hanging Glider"¹ is worthy of mention; we cannot deny it a certain right to existence as we know the earliest attempts at flying were made in this kind, and though there is now no question of using such a type for regular instruction, it still serves its purpose as a means of attracting the younger generation. It is cheaper than the primary glider, so anyone who only wants to make a few "hops" in the air and finds the slight difference in price between the two machines a strain on his purse, then—if that is the only way for him to fly at all—let him build himself a machine similar to those used by the pioneers of gliding. He will hardly learn much about flying because the control is essentially different from that of any other type of glider. The "Hanging" glider is controlled by shifting the position of the body, a task which requires great athletic skill and gymnastic training, it therefore develops these factors rather than actual flying capacity. The essential points about such a flying machine are its lack of weight (it should be light enough to be carried by a man) and cheapness. It must also be controllable and possess a gliding angle which will enable it to fly in any fairly normal country. As the control can only be obtained by means of bodily movements, the span of the wings must not be too wide, but on the other hand the surfaces must be large enough to prevent the machine from developing too great a speed, otherwise running starts against the wind and landings, in which the pilot's legs must replace the undercarriage, would be quite impossible. Such large surfaces in conjunction with a small span and weight can only be obtained in the biplane type. Monoplanes have been found impracticable. Owing to its lightness such a machine is naturally not very strong, but it need not be so, for it would be madness to fly a "Hanging" glider in any but the calmest weather or, at

¹ "Hanging Glider" is the literal translation of the German "Hängegleiter" and is used as there is no accepted word in the English language describing that early form of glider from which the pilot hung by resting his forearms on cross-battens, with his legs dangling through a hole in the plane. In this type of glider level flight was maintained by swinging the legs from side to side to preserve the balance. The legs were also used in place of the skid or wheeled-undercarriage which modern gliders possess.

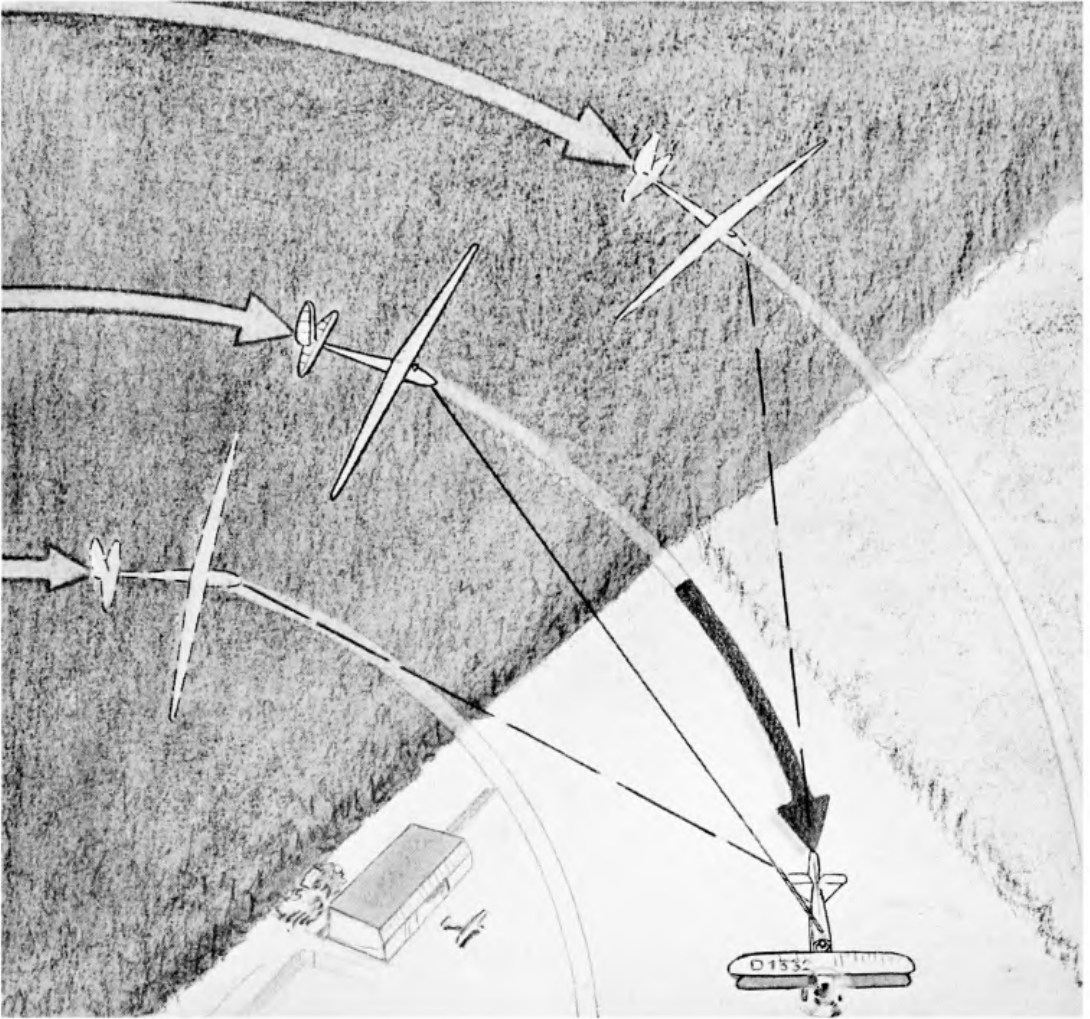

68. TURNS IN AN AEROPLANE START. IF THE SOARING PLANE TURNS ON THE INSIDE OF THE AEROPLANE IT DESCRIBES A SMALLER ARC AND SO LOSES HEIGHT. IF IT TURNS ON THE OUTSIDE OF THE AEROPLANE, IT RISES. THE SOARING PILOT CAN THUS REGULATE HIS HEIGHT DURING A TURN

Facing page 254



69. THE EARLY DAYS OF GLIDING. WOLF HIRTH, THE FAMOUS SOARER, EXPERIMENTING WITH A HANGING GLIDER ON SKIS



70. A DIFFICULT LANDING IN A HANGING GLIDER

Facing page 255

most, in a very gentle, steady breeze. Control by means of the pilot's weight becomes impossible as soon as any rough gusts are encountered, in which case the inevitable crash is bound to ensue.

As is the case with all aircraft, the most important component of the "Hanging" glider is the main wing. It is also provided with a rudder and elevators, but they are rigidly connected and cannot be moved by the pilot during a flight. One of the most successful builders of modern "Hanging" gliders was undoubtedly W. Pelzner, of Nürnberg, who, by dint of incredible energy succeeded in achieving good results with his machine in the first Rhön meeting. A glider which he built in 1921 had a span of about eighteen feet, a wing area of about one hundred and fifty square feet, and a weight of twenty-one pounds. This machine was really well built and proved a striking testimony to Pelzner's technical and constructive knowledge and skill. Other biplanes which he built had spans varying from twenty to twenty-three feet, surface areas of one hundred and fifty to one hundred and eighty-three square feet, and weights of thirty-seven to forty-two pounds. In all these gliders the pilot hung by his arms from an aperture in the lower wing and balanced the machine with his body. In the competitions of 1921 Pelzner often made as many as six or eight flights on one day, flying altogether from two and a half to three miles. This feat was, however, chiefly a physical one, and in any case the man who would fly a "Hanging" glider must clearly understand that he will need absolute control over his body in addition to a capacity for enduring hard knocks.

In the ordinary school glider or primary type the pilot has a seat. This primary is a descendant of the "Hanging" glider, from which, however, it differs in several important respects. The pilot sits in a seat, the control surfaces are movable and the machine has an undercarriage for starting and landing purposes which generally takes the form of a skid. All of which relieves the pilot from exhausting physical work.

The experience which has been acquired by years of instructing pupils has shown us exactly what we have a

right to expect of such a glider. The fundamental requirements are : cheapness, good flying qualities, safety, and a gliding angle sufficient to secure fairly long flights over normal training grounds. The machine which best fulfils all these specifications at present, is a braced monoplane of the simplest form, with an open girder carrying the tail. For want of a better name, this fundamental type may be described as light-wind planes. They obtain a low sinking speed at the expense of a good gliding angle, by reducing the wing-loading.

For cheapness sake these machines must be built of material that is easily obtainable. The wood chiefly used is ordinary pine or fir, the more expensive plywood being employed only when absolutely necessary. The cost of such machines could be reduced by a system of mass production which would shorten the hours of work necessary for each individual machine. Repairs must be simplified as much as possible by standardization of separate parts so that each damaged part can easily be replaced, thus saving much time, money and trouble.

Such gliders are required to possess inherent stability. The beginners' ideal school machine must start, fly and land well without any interference on the part of the pilot. If he lets go of the control column, the glider must right itself automatically, while at the same time it should be capable of helping the pilot to gain flying sense by reacting immediately to his lightest movement. Special attention must be paid by designers to the glider's behaviour in critical moments, such as cases of nose-diving, stalling or side-slipping. The speed should not increase too rapidly if the pilot pushes on the control-column too much. It should be possible to stall gently without immediately losing all control. The glider should recover from a side-slip by itself without diving rapidly. For all these requirements, the drag, wing-section and plan form, position of centre of gravity and the size of the control surfaces are of the utmost importance.

When all these conditions are fulfilled, the pilot's risks will be considerably decreased. If a glider has good flying qualities, it will generally refuse to let itself be forced into

a dangerous position. Of course, anything is possible with beginners ; one must be prepared to see them stand the glider on its head, stall, side-slip or ram the ground when landing. The result is a crash which must not be the cause of inflicting severe injuries on the unfortunate pupil.

To begin with, he is strapped in, so that the greatest force of the shock is absorbed by his broad safety-belt. There must be no splinterable wooden parts for his body to fall against, therefore the need is for a machine so constructed that there are no wooden parts in front of the body. The cockpit must not be enclosed, and no main strut must run in front of the novice's head. It was not possible to avoid this last defect entirely in the earliest school gliders, and the struts in front of the pilot were nicknamed, with some semblance of truth, "skull splitters." Now that this danger has been eliminated, the belt breaks in a crash landing and the pilot falls on to the soft grass. The considerable attention given to an infinite variety of such seemingly insignificant points has already, in countless instances, led to the avoidance of badly-broken bones. If, for example, the rudder bar is so placed that the pilot can sit with his legs bent, no bones will be broken by jolts or jars, as is the case when he sits with his legs stretched out.

A gliding angle of from one in seven to one in ten will be found suitable for most flying fields. A smaller angle means shorter flights, but a greater one is not free from danger. For flights in hilly regions, in particular, the gliding angle of a beginner's glider must not be too great. If it is to be used for instructional purposes it should also be built in such a fashion that it will land of its own accord after a short flight ; otherwise a pupil may be unable to bring it to the ground and find himself hovering far above the valley, utterly without flying experience. It is therefore obvious that both the type of glider and the choice of terrain are essential factors.

A splendid example of the class of glider which fulfils all the above requirements is the "Zögling." It is a braced monoplane with an open girder body, the wings of which have two main spars consisting of fir or pine boards set on

edge. They are cheap, and if broken can easily be glued together again. The ribs are made as cheaply as possible.

The wing section is of the medium thick kind. The wings are strengthened by a ply-wood leading-edge extend-

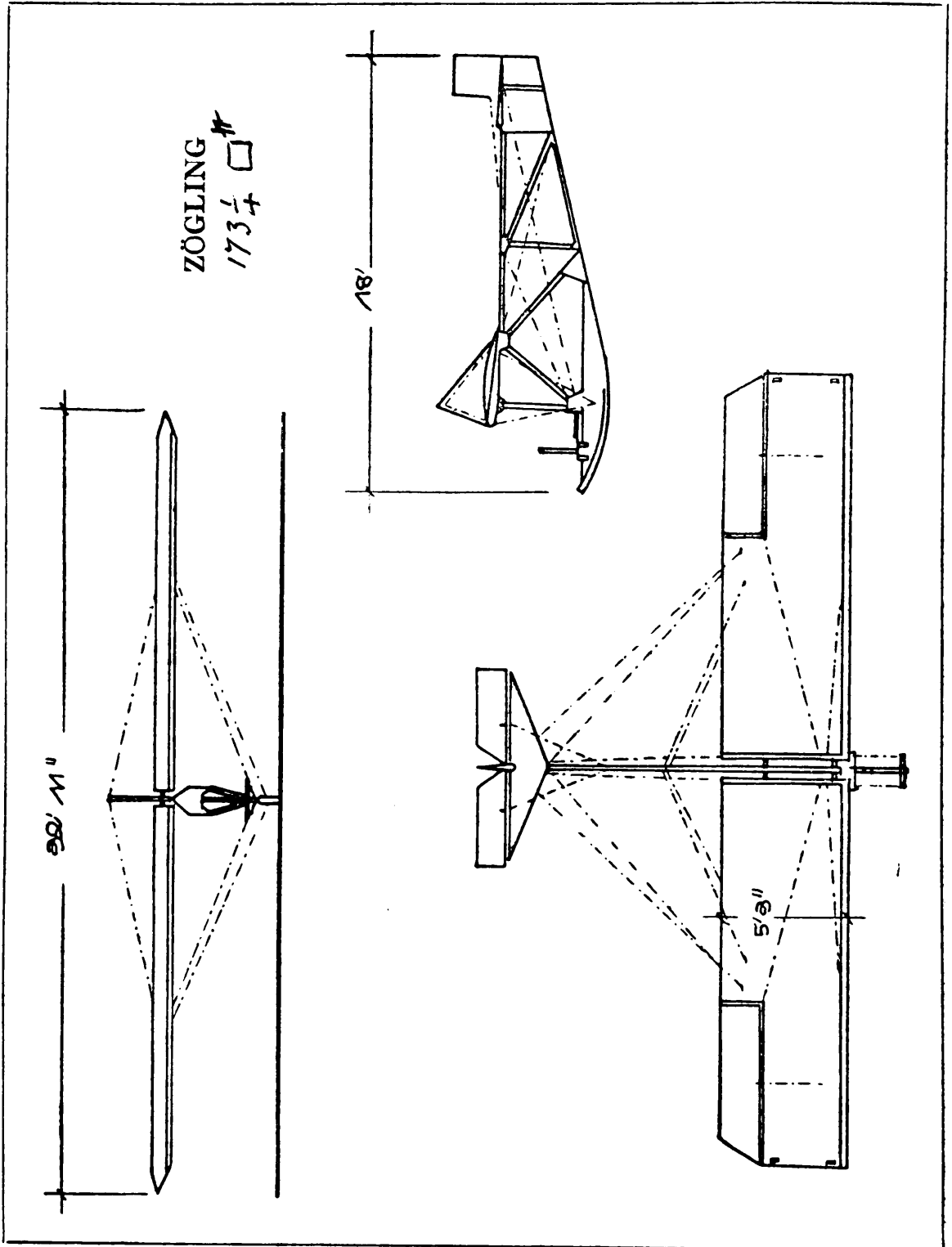



71. A "ZÖGLING" IN THE AIR. NOTE THE OPEN SEAT AND THE SIMPLICITY OF THE MACHINE'S CONSTRUCTION

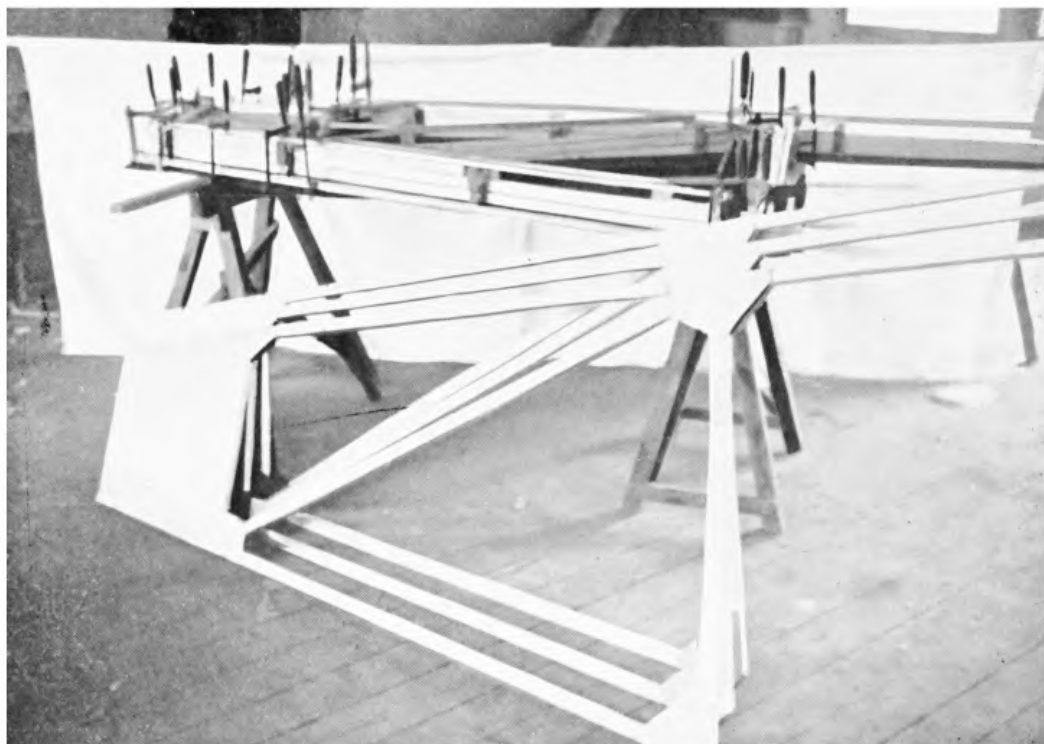

72. THREE LATTICED TAILS IN PROCESS OF CONSTRUCTION FOR ZÖGLING MACHINES

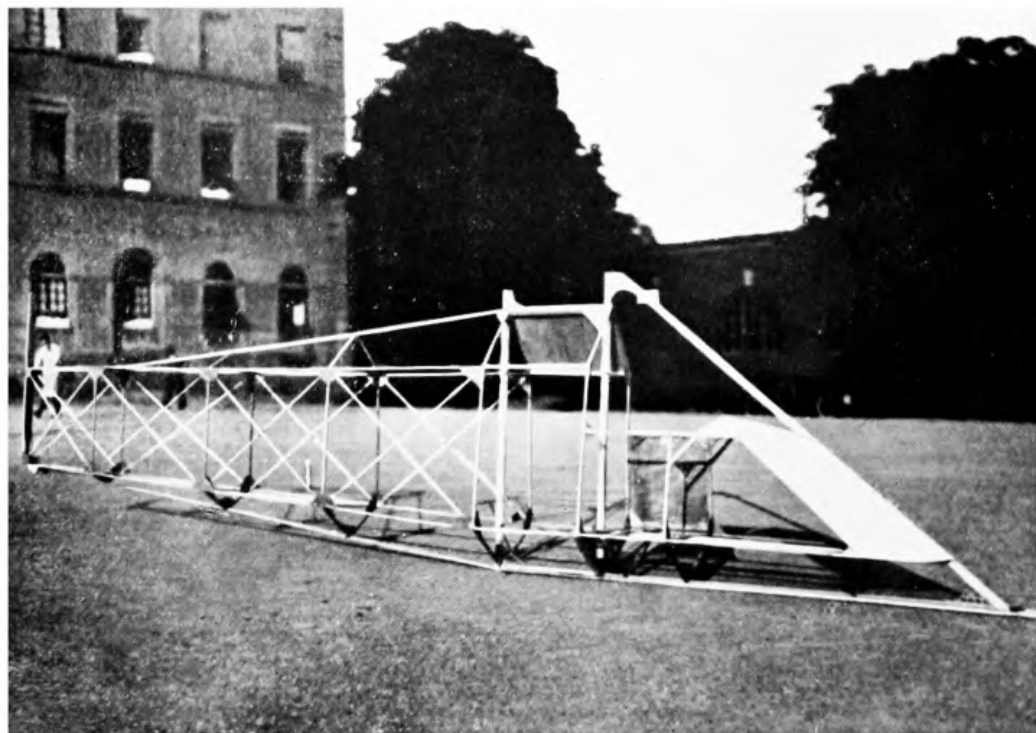

73. THE FUSELAGE OF A LIGHT WIND MACHINE. (The Stuttgart Academic Flying Group)

Facing page 259

ing as far back as the front spar, and an internal drag bracing system of stiff wooden diagonals. The fuselage or body is a very strong open girder with ply-wood fitch plates or "biscuits" either side of each important joint. This girder has a triangular top extension forming a kingpost to which both spars of both wings are braced while the lower bracing or flying wires run from the bottom of the girder up to the spars. The tail unit is braced each side to the wings and all the control surfaces are stiff enough to withstand torsional forces.

The price of such a glider is not very high. A beginner's glider can be bought from a good factory for as little as forty or fifty pounds. If you build it yourself, you save the expense of the workmen's time, which is, after all, a large proportion of the total cost. When we consider the fact that many people can practise with the same glider, all of whom would be ready to contribute their share to the purchasing fund or to give a few hours helping to build it, we see that it ought not to be too difficult for such machines to become popular in any country.

The glider employed for maintaining and increasing the skill acquired in a "Zögling" and for elementary soaring, is called the intermediate type. Like the school gliders, these are nearly all single-seaters. It is, however, desirable to have on hand a number of two-seaters in which a soaring instructor can take up a pupil for his first soaring flight, in order to give him a practical demonstration of the right way to handle a machine in an up-current and to make turns above a slope.

There are two directions along which gliders possessing good soaring qualities may be developed. The first produces machines with an extremely low sinking speed which develop into the typical light-wind sailplane with minimum wing-loading. The wing is greatly enlarged, but the weight on the other hand, is kept down as much as possible; this can be done best by having braced construction. The other direction lies in an improvement of the gliding angle. These machines are built with a minimum drag, and with a structure and formation similar to that of the high-efficiency machines used by expert pilots. This type cannot have an

open girder fuselage, on account of the large amount of drag it creates, while on similar grounds bracing wires must be replaced by simple struts.

Gliders of both these classes must naturally comply with the demands made on school machines. The pilot who is about to make his first soaring flight is by no means sure of himself. He is often guilty of the use of excessive control and liable to make heavy landings. Therefore these gliders must be strong and capable of standing rough treatment although it is not necessary for them to have the thorough solidity of the school gliders. But they must be able to behave well in the difficult situations which may arise during a flight.

The necessary manoeuvrability and ease of control are more readily obtained in the type with the heavier wing-loading and larger fuselage than they are in the light-wind sailplane. In the latter type the rudder control and sometimes that of the ailerons is often very sluggish. Increasing the control surfaces alone does not help and other aids have to be employed. The wing tips must be rounded and have a more suitable section while the ailerons can be arranged to work differentially, that is, with a larger upward than downward movement.

These various qualities of the two types of machine should enable us to determine for which branch of instruction they are suitable. If a pupil desires to learn soaring in order to devote himself later to flying a motor-driven aeroplane, the best machine for him will be the one which in its flying qualities most nearly approaches the motor-driven types. His choice would naturally fall on the semi-cantilever strutted monoplane with enclosed fuselage, as this type is relatively speedy and easy to manoeuvre; moreover it can be so constructed that the knowledge acquired from handling it can be applied directly to motor-flying. From the point of view of flying, the pupil will also find little difference between this type and the cantilever motor-driven aircraft which he will eventually have to pilot. Cantilever machines are not therefore built for soaring instruction because heavy landings lead all too easily to breakages of the unsupported wings. On the other hand,

soaring instruction in light-wind sailplanes has the great advantage that it gives the future expert pilot an opportunity of growing accustomed in good time to the sluggishness of the ailerons. If the glider is to be used especially for this

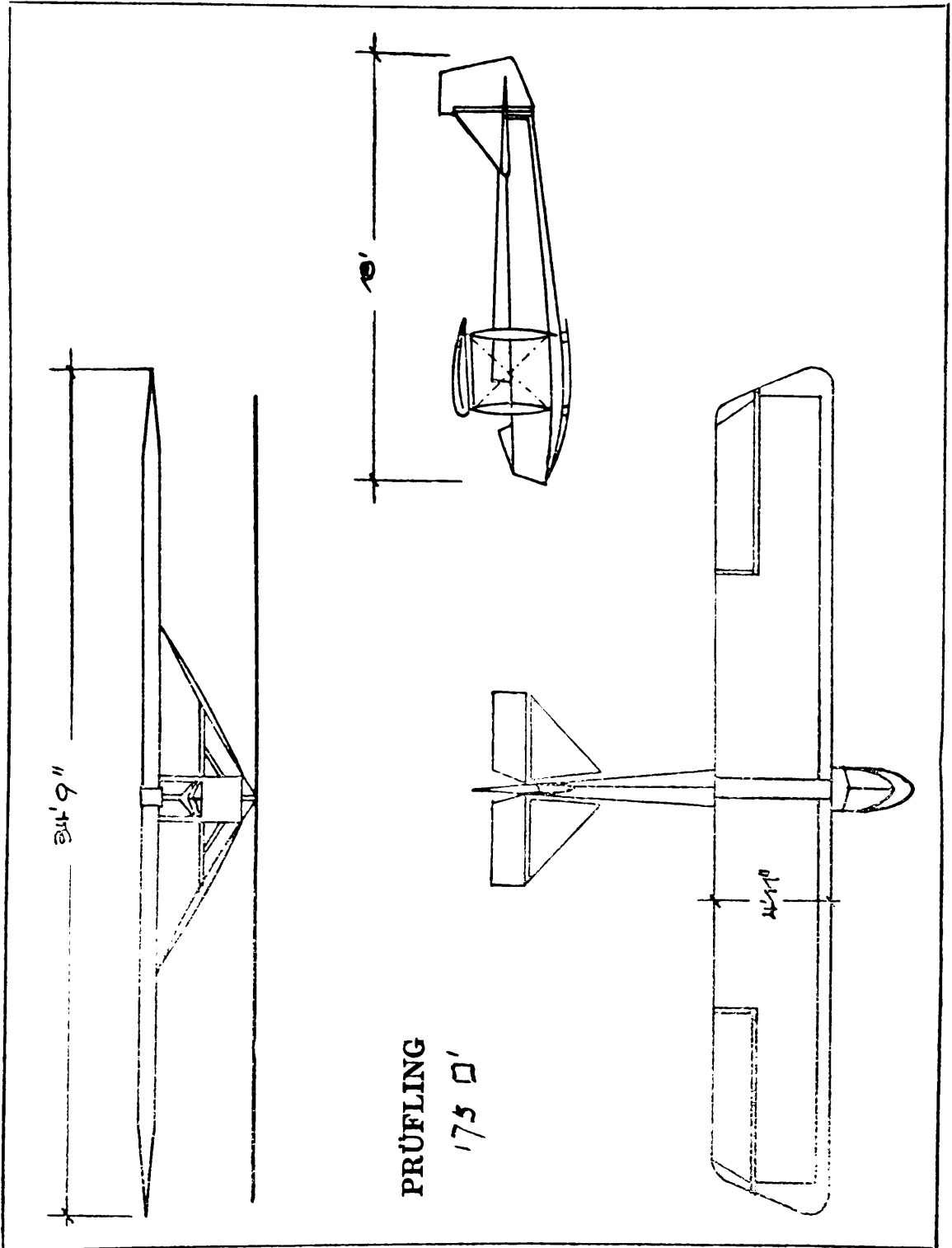

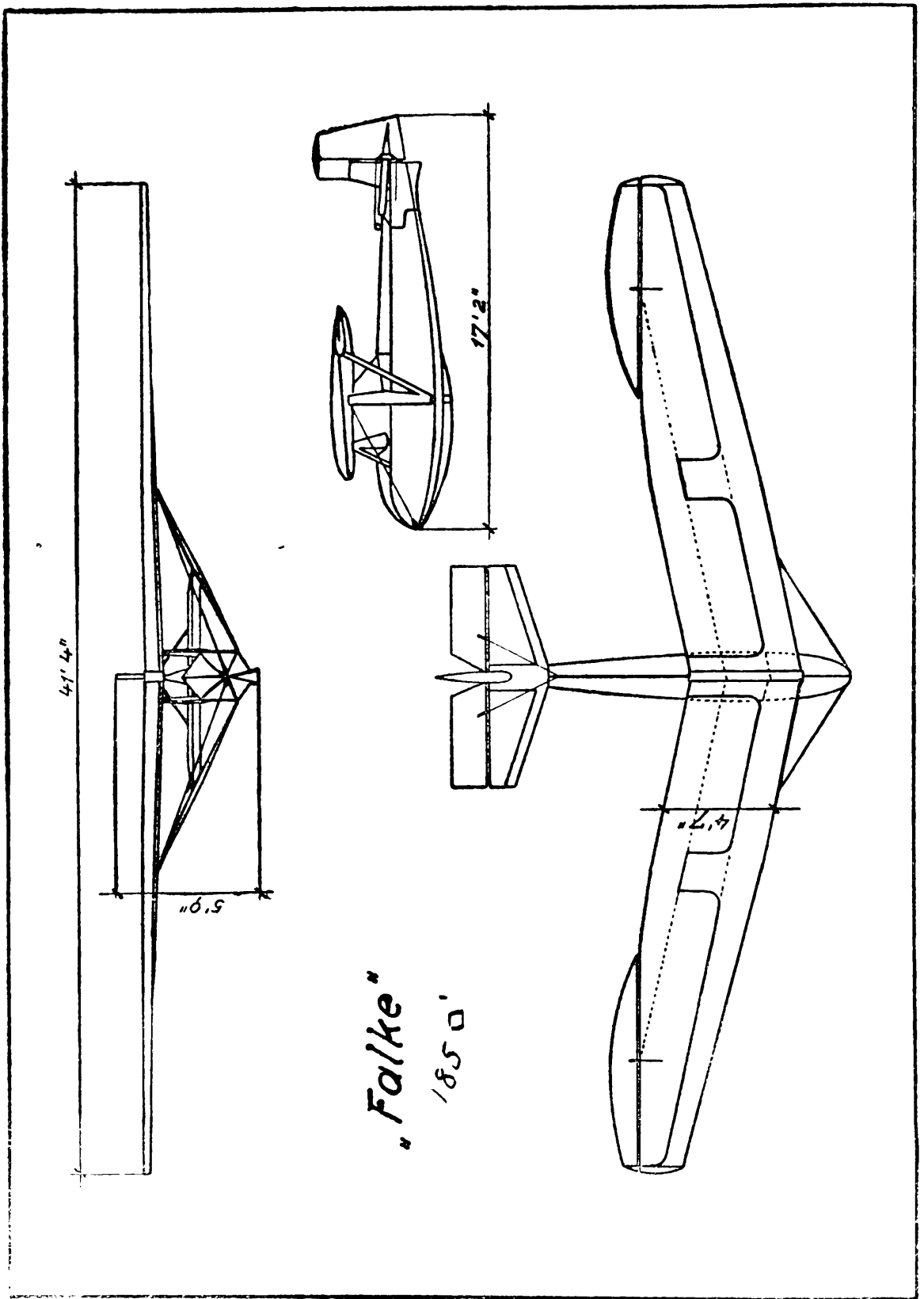

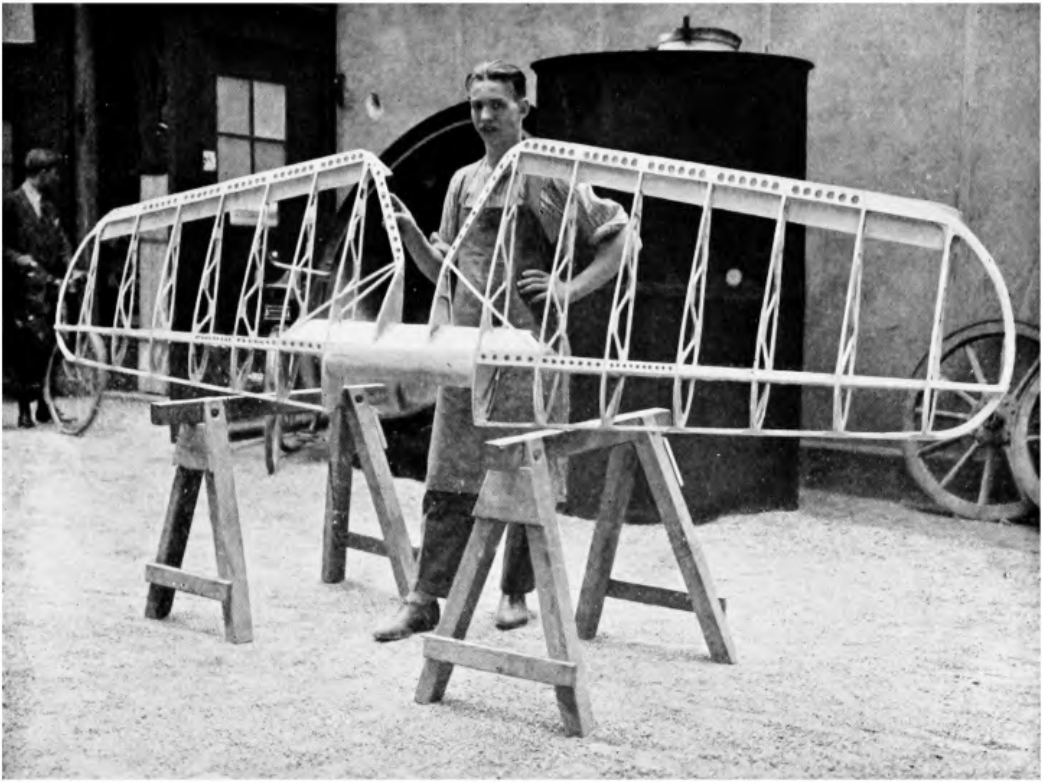

74. THE ELEVATOR. (The Darmstadt Academic Flying Group)

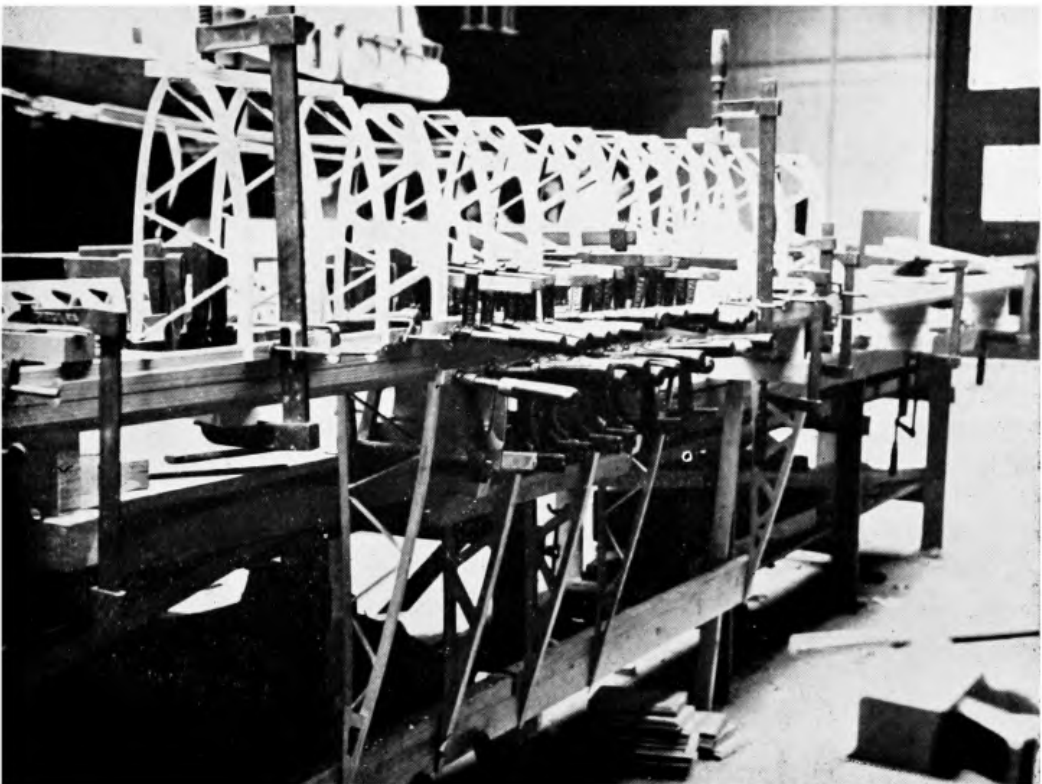

75. FITTING THE RIBS ON TO A ONE-SPARRED WING. (The Darmstadt Academic Flying Group)

Facing page 262

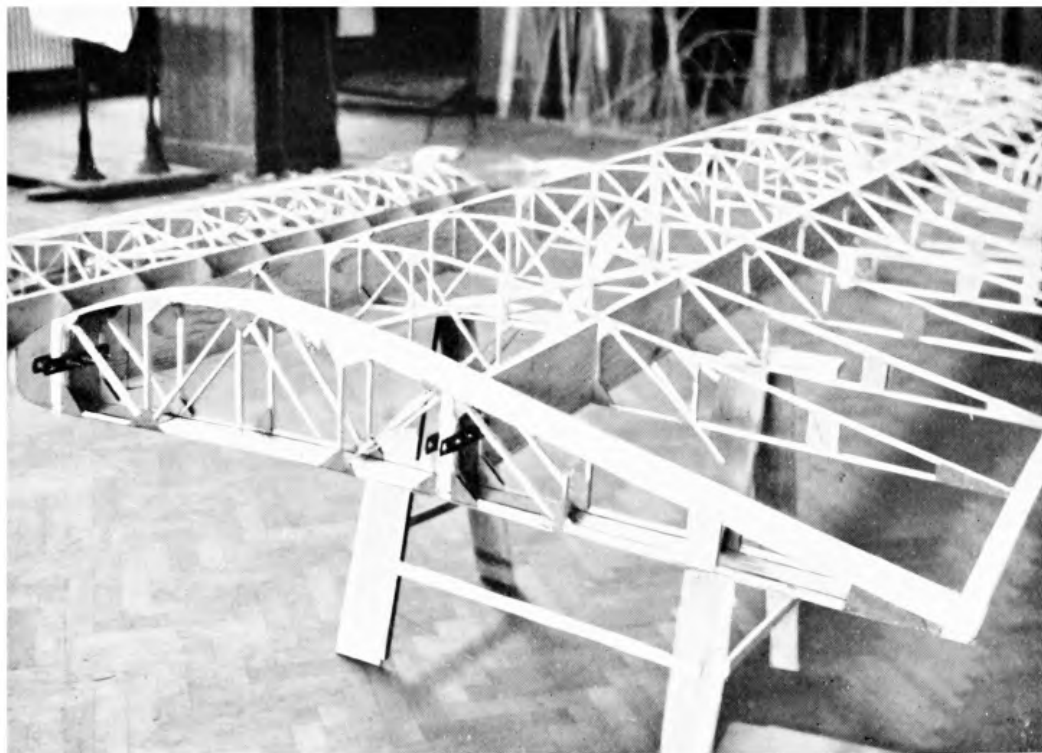

76. WING-STRUCTURE OF A PRIMARY MACHINE



77. A SCHOOL DOUBLE-SEATER IN FLIGHT

Facing page 265

kind of training, it is advisable to give the pilot the same sort of streamline-cockpit which he will afterwards occupy when he ultimately takes his place in the cockpit of a high-efficiency machine. Thus his transition from one type to the other is facilitated.

There are models of the primary type which we may almost term classical. The Rhön-Rossitten Ges. "Zögling" is the school glider which so far has the greatest number of starts to its credit in the whole world. The "Prüfling" is its soaring counterpart; anyone who has flown the latter is bound to appreciate its grace and the ease with which it can be manœuvred in the air; at the same time it is, perhaps, even more tolerant of stalling than the "Zögling." It has two spars to its wings and a narrow ply-wood leading-edge. The two spars which are in boxed form have diagonal drag-bracing between them, and by virtue of the two struts which brace the wing to the fuselage (the struts also having cross-bracing wires between their ends) the whole wing is extremely strong against bending and torsion. The ailerons are large and effective. The fuselage has a hexagonal cross-section. Along each corner runs a longeron which with bulkheads and diagonals completes the light but rigid structure. The forward part of the fuselage is entirely boxed in with plywood, and is specially strengthened to protect the pilot in case of a crash. The skid is rendered elastic by rubber pads attached to it at two points, which absorb the force of shocks, thus preventing wing breakages in heavy landings. The after-part of the fuselage, which is covered with fabric except for the bottom where plywood is used, merges directly into the fin which carries the rudder. The tail plane is braced by small struts, while the elevators are operated by double wires. The pilot's seat is within the fuselage and yet under the wing, an arrangement which affords him a good view and gives him the feeling of being himself a part of the machine. If the "Prüfling" capsizes, he is protected by the wings.

Four short bracing struts run upward to the two main plane spars beneath which the pilot sits; these are the middle points for the attachment of the wings. The whole of the section in which the pilot sits is so strongly built that

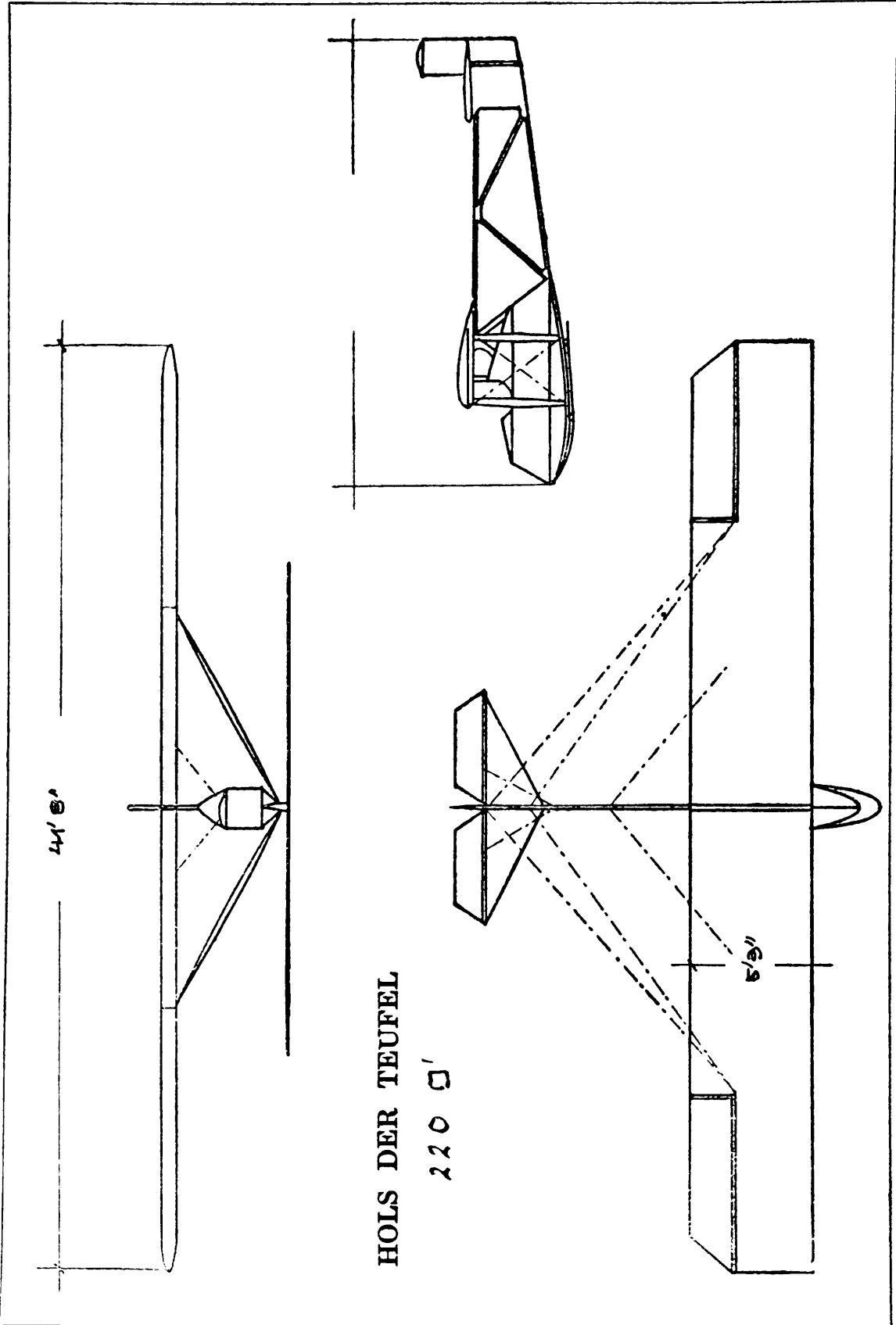

HOLS DER TEUFEL

220"

24' 6"

5' 6"

even in a heavy crash it will remain more or less intact and afford him protection. The control is effected by means of the usual stick, while the rudder is operated by pedals. This glider is comparatively simple in its construction ; it is easy to repair and cheap to build.

A number of disagreeable qualities which the "Prüfling" still possessed urged people to replace this machine by the "Falke," a machine which is far superior. The "Falke" has a lower sinking speed as well as a lesser speed in nose-dives than the "Prüfling," the latter point being of vast importance for schooling purposes. The aileron control is sensitive, which means that the main defect of all soaring gliders has been eliminated. The improvements of this machine, compared with the "Prüfling," have, however, made a more complicated construction necessary. We have to thank Alexander Lippisch, who used all the knowledge gained in designing tailless types for this new machine.

Another type, the speciality of which is a very light wing-loading, is the "Hols der Teufel." This is also wire braced, but it has an open girder fuselage similar to that found in the "Zögling." To lessen the drag the pilot sits in a small boat-shaped nacelle. The tail unit is braced with struts of considerable strength. The weight is very small and the surfaces are large. The structure is similar to that of the "Zögling," but it is also possible to build such machines with strut bracing. Their flying qualities will not be impaired by this, if care is taken to comply with the fundamental conditions, large surfaces and small weight.

The two gliders described above are merely typical examples of numerous machines, all of which are designed on one or other of these constructive principles. In the "Prüfling" type attempts have been made to increase the width of the span, and light-wind soarers have been constructed with the girder type fuselage built of tubes of steel or duralumin. Machines of the "Zögling" type have also been seen with fuselages constructed of steel tubing—an excellent material for use in localities where material and workmen are accessible for repairs.

As we have already remarked, both classes contain

two-seaters which have proved their worth. The constructive problems to which they give rise are caused by the difficulty of providing such large machines with flying-controls which are in any way similar to the normal machines of the same type. And a two-seater soarer must be a large machine, if only to obtain the flying qualities necessary for carrying the double load. A very good solution of the problem is supplied by a glider, in the construction of which steel tubing plays an important part. The school two-seater, designed by Krekel, "Mecklenburg M III," is a braced monoplane which has been developed chiefly with an eye to good flying qualities. The wings are constructed in four parts, the inner being square ended. The outer sections are attached at the bracing points and have a triangular plan form with rounded tips. In the inner section the two spars have diagonal, wooden strut drag-bracing between them and in the outer section the two spars come together at the tips. The ailerons are large and extend the whole length of the outer wings. With the exception of the wing all parts are built of steel tubing. The cockpit in which the pilot and passenger sit is covered with doped fabric. This glider has excellent flying qualities, either as a single-seater or a two-seater, in the former case its strong point is that it has an extraordinary low sinking speed, and may be used as required for a variety of purposes.

The "Mecklenburg M III" was evolved from the light-wind type, but the "Hercules," two-seater, designed by Arnold, is a clever development of the "Prüfling" type. It has a two-piece wing, which is braced to the fuselage by two parallel struts. On the fuselage itself the central section is not secured at four points but by means of two supports projecting from the framework. The elevators, unlike those of the "Prüfling," are not on the fuselage but are located on the fin, where the lofty position shields them from injury on landing and has proved a most useful means of holding this glider while being launched.

Although the two-seater has hitherto played no great rôle in training work, it has been most useful as a means of propaganda. It affords a skilled pilot an opportunity of

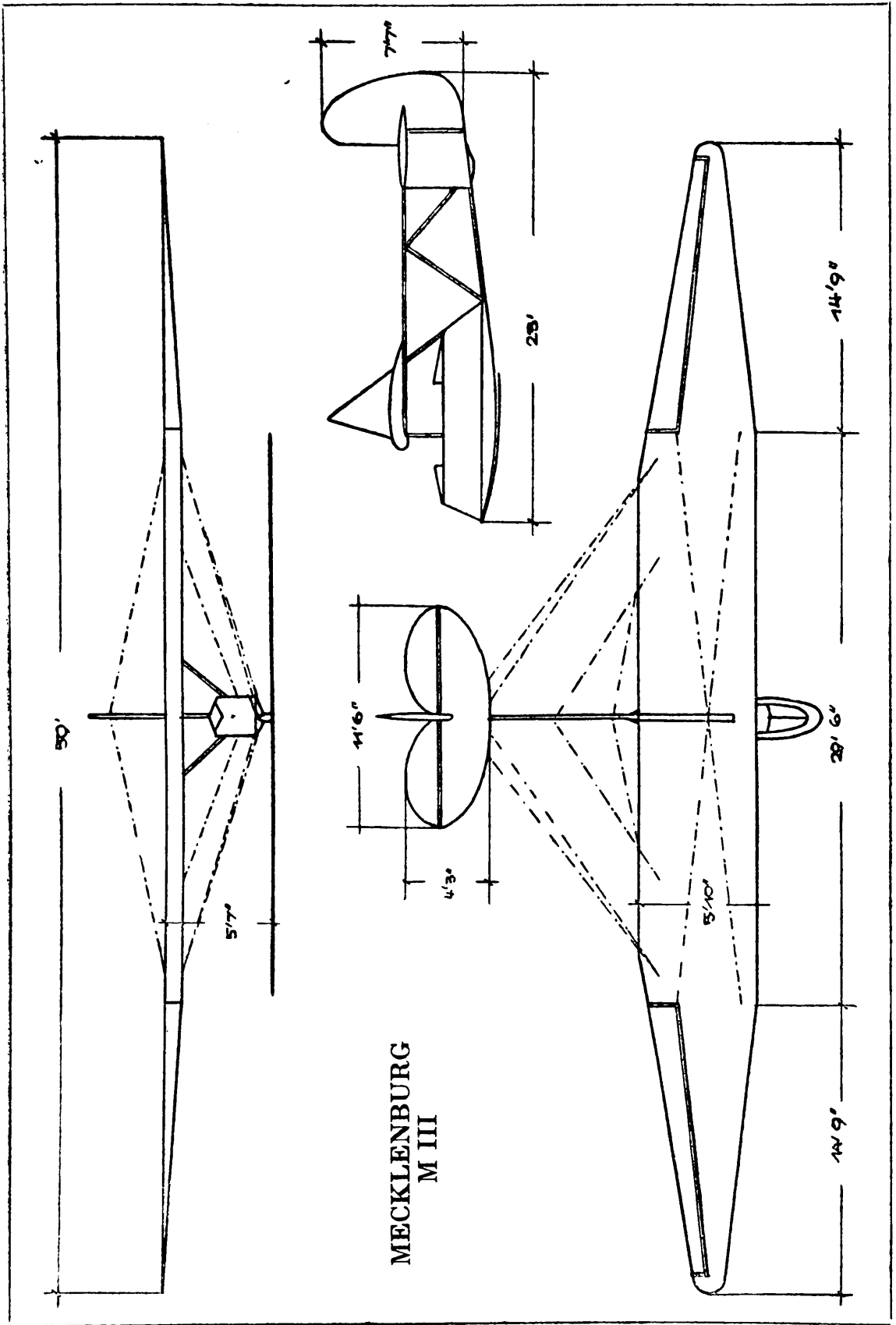

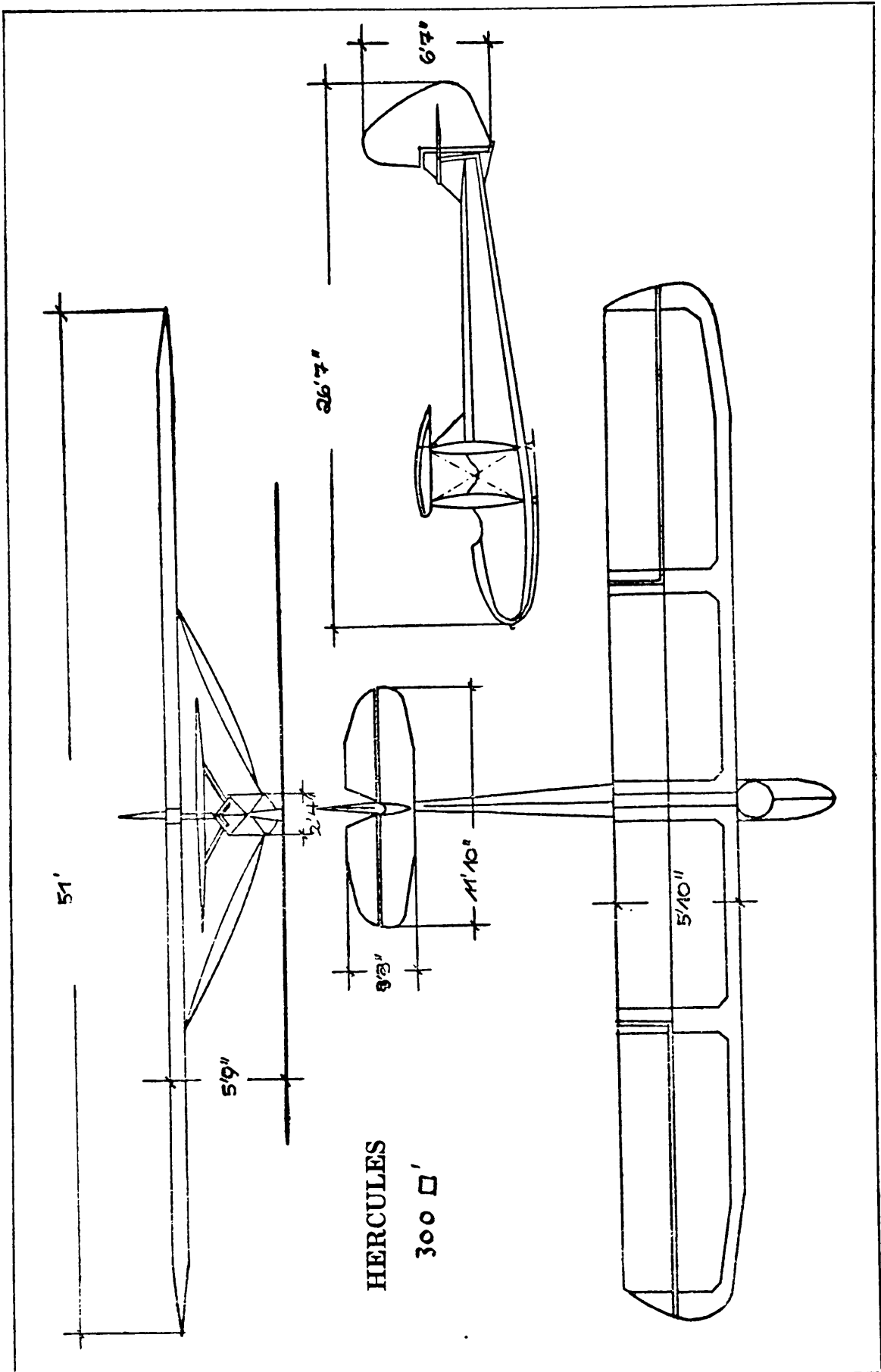

taking up many passengers on a good flying day and bringing them back to the place from which they set out ; such flights, as aforesaid, do more to stimulate interest in flying than propaganda by means of the spoken or written word.

Naturally such two-seaters cost more to build than the single-seater variety of the same type, since they require considerably more material and many more hours of work. The prices for a "Prüfling" or for a glider of the "Prüfling" type range from fifty-five to sixty-five pounds, and those of a light-wind soarer from fifty pounds to seventy-five pounds, but one must expect to pay about double these sums for a two-seater of the same type.

The ability of the constructor is more exercised in the building of high-performance sailplanes. It is certainly much easier to build a motor-driven aeroplane that will fly well, than a sailplane with which special flights can be made ; it is therefore the ambition of every constructor to do his best in this direction. The main objectives, which all pilots continually emphasize are : a better gliding angle, a lower sinking speed and greater powers of control. It is also very desirable to have a machine which can be flown quickly or slowly at will without impairing the gliding angle or the sinking speed. The design of such a machine entails many conditions in which an advantage in one direction is generally offset by a drawback in another. The further we progress, the more value we must set upon a thorough aerodynamical education, but this cannot be explained without pre-supposing special mathematical knowledge on the part of the reader, therefore it will be impractical to go into further details in this book.

Yet even the lay reader will perceive that all parts which offer resistance to the air must be eliminated as far as possible. This has led to the development of cantilever-winged sailplanes with smooth, streamline fuselages from which only the pilot's head projects. Nature has provided the best soarers among the birds with extremely narrow wings of the greatest possible span, moreover it has been demonstrated mathematically that the drag of the wings decreases as the span increases (for the same area). This is the reason for the constant increase of span, coupled with

the continuous improvement of the aspect ratio, i.e. the proportion of the mean chord to the span. The construction of such sailplanes is rendered easier for the designer by the fact that they are (or should be) flown only by first-class pilots. It is therefore unnecessary for him to allow for ignorance or carelessness which will put the machine into dangerous positions or will land it in such a way as to subject fuselage and wings to any greater strain than they undergo during the flight itself. Also, it is of no great consequence if the effectiveness of all the control surfaces is not so perfect as in beginners' machines, although this last factor is one of which many constructors are inclined to take too much advantage.

The forerunners, as it were, of these high-performance sailplanes were flown during the first Rhön meetings; therefore I shall first discuss Klemperer's "Blaue Maus" and the Hannover-design "Vampyr." The "Blaue Maus" was a great improvement upon all other sailplanes of that time and is still in many respects, especially as regards lightness, a miniature pattern for designers. The monoplane wing was cantilever; the machine had a thick wing section and was extremely lightly built. The wing, which had no internal drag-bracing, had three spars, and was perfectly triangulated. The total weight of the wing ribs was only about eight pounds. The weight of the finished wings was about fifty-five pounds and that of the slantingly attached ailerons less than two pounds each. The fuselage was constructed in three parts. The foremost of these, which was made of bamboo rods was calculated to afford protection to the pilot if the machine turned over. The fuselage was of round cross-section with the tail surfaces merging into the rear end. The pilot sat fairly high up in the fuselage above the front spar. The plane had landing skids, which were attached on both sides at the same points of junction as the wings. Each part had a streamline fore and aft section, while the ashwood skid was sprung by rubber buffers. The whole machine was covered with fabric.

This sailplane was a marvellous achievement for its time, but a year later the "Vampyr" revealed a form of construction which still satisfies all the needs of the present day.

BLAUE MAUS

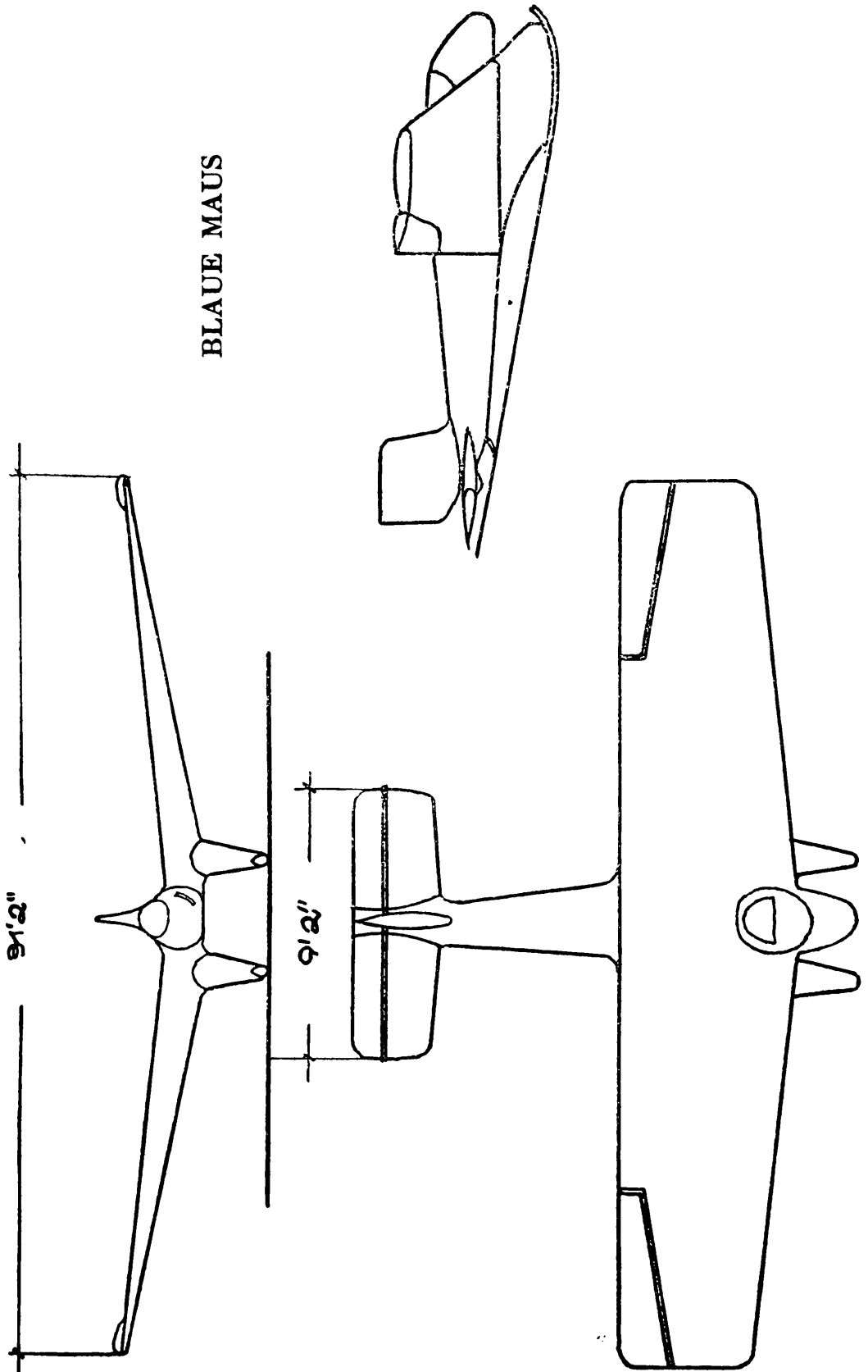

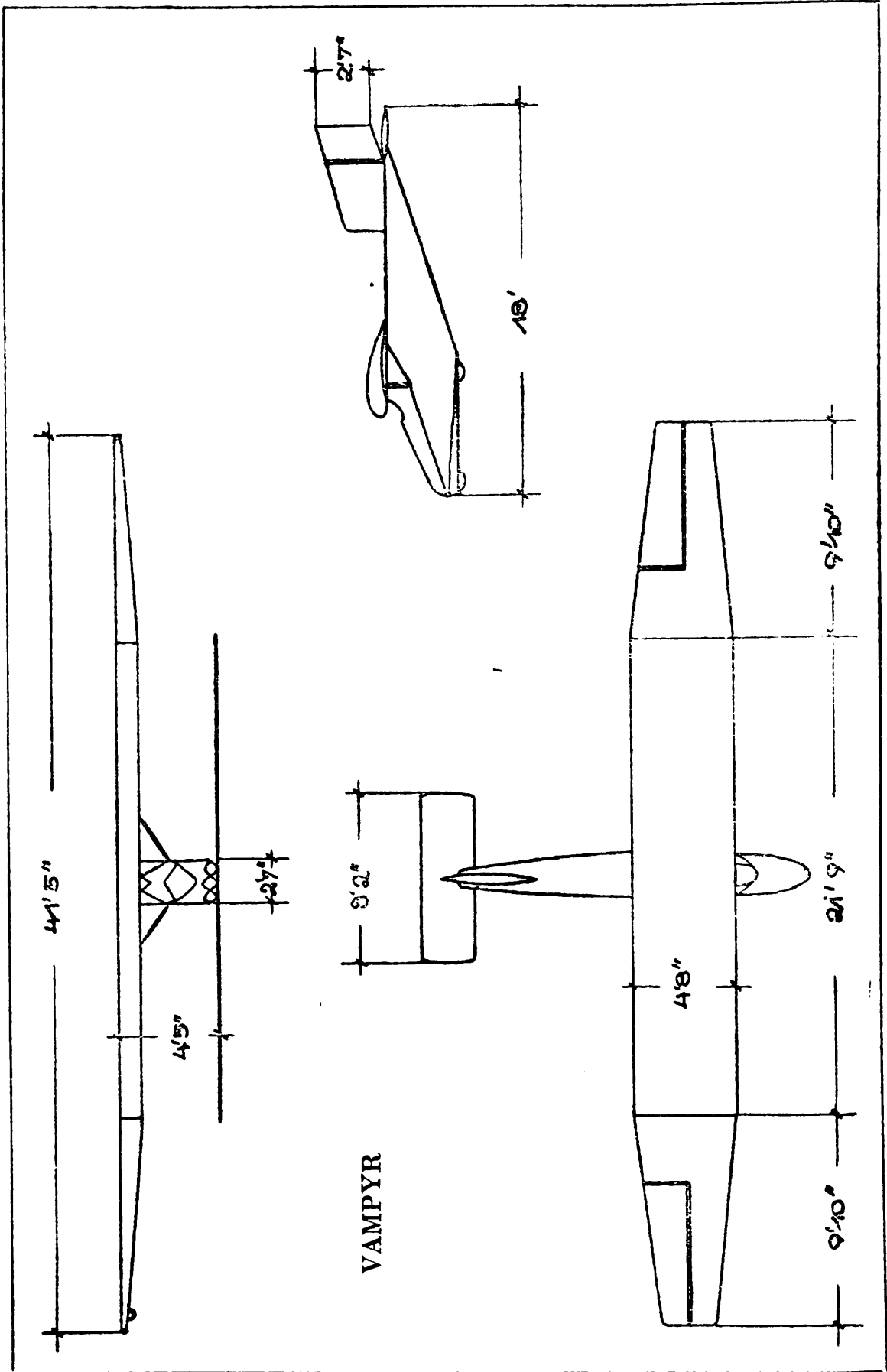

This unbraced monoplane of the Hanover Flieger Gruppe, which was evolved with the help of Professor Pröll and the Dipl. Ing. Madelung, was the first to demonstrate clearly, the importance of aspect ratio. In this machine it was 1 to 10.8. The wing surface consisted of a twenty-foot-long middle part which rested upon the fuselage and was attached to it by two struts. The outer parts of the wing were ten feet long and carried the ailerons. The wing had only one spar, and torsion was taken by a plywood nose. The ribs were built up as light girders. The fuselage had a square cross-section and curved upwards behind, thus enabling the pilot to drop the tail deeply when taking-off and landing. Typical of this machine were three footballs hung upon axles, which acted as excellent shock absorbers when landing. There was no tailplane in front of the elevator. The rudder and the fin were very large. The machine weighed a hundred and fifty-four pounds without its pilot.

But although the "Vampyr" was an excellent machine, it has been easily surpassed by the high efficiency machines of to-day, all of which are built to a standard form. Those which I am about to describe have been credited with the greatest successes in recent competitions.

The "Westpreussen" was designed by the Dipl. Ing. Hoffmann, of the Darmstadt School. Nearly all the sailplanes of this type have a square middle section to which are attached elliptical outer planes. The wing has one spar and a plywood nose. The ailerons are large. The cross section of the fuselage is oval. In the very latest model, the "Westpreussen," the wing rests directly upon the highly-streamlined fuselage. The skid has rubber buffers.

There is a striking resemblance between the forms of the "Westpreussen," the "Lore," and the "Starkenbourg." All these three machines are from the Darmstadt School. The "Lore," which was so successful in Hirth's skilful hands in the 1929 competitions, is typical of the construction from this school. A small structure is erected above the fuselage which bears the wing. The pilot sits immediately beneath the front part of the wing. The body has an oval cross-section, tapering to a fine edge underneath. When viewed from the side, the fuselage is deeper than in

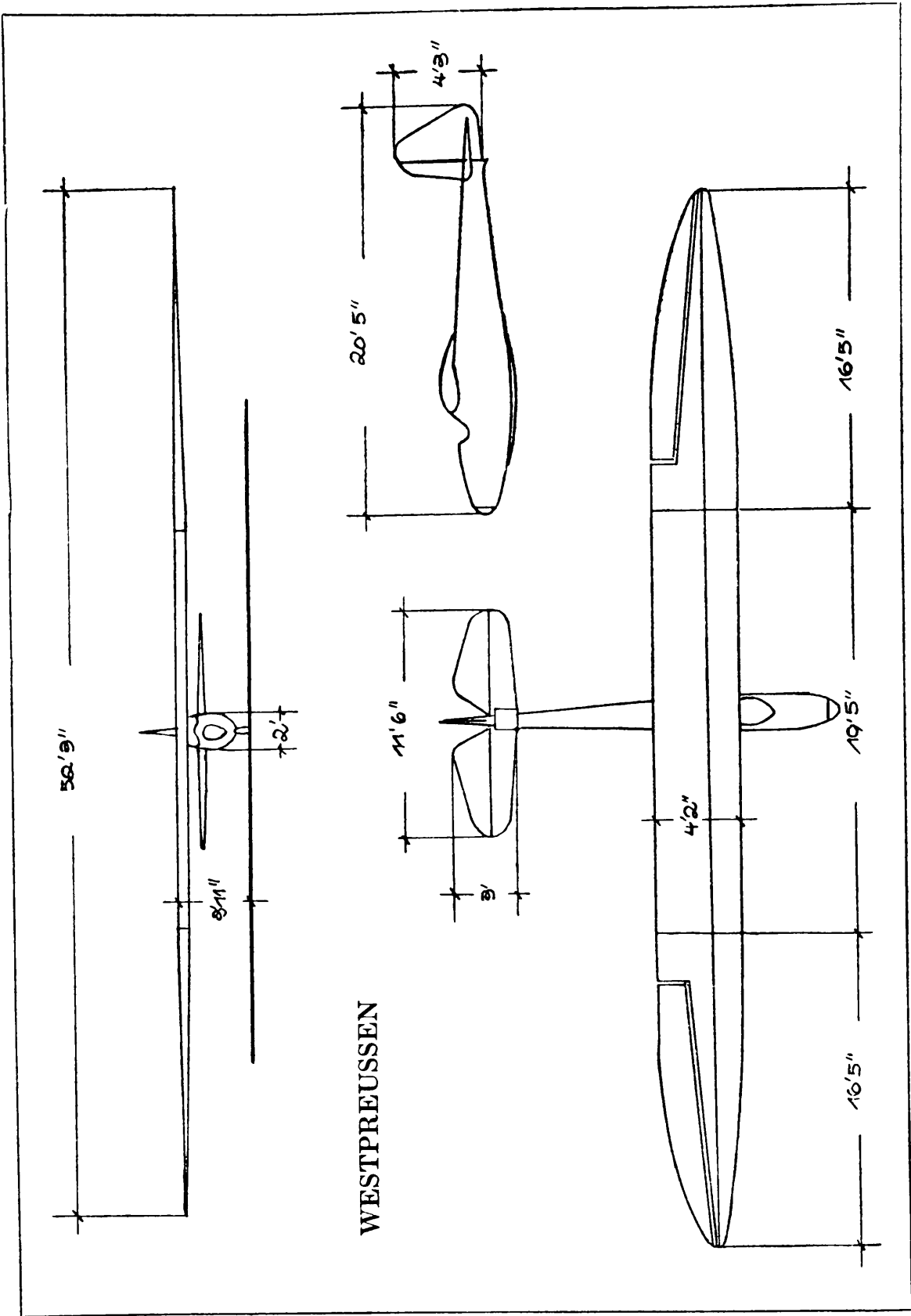

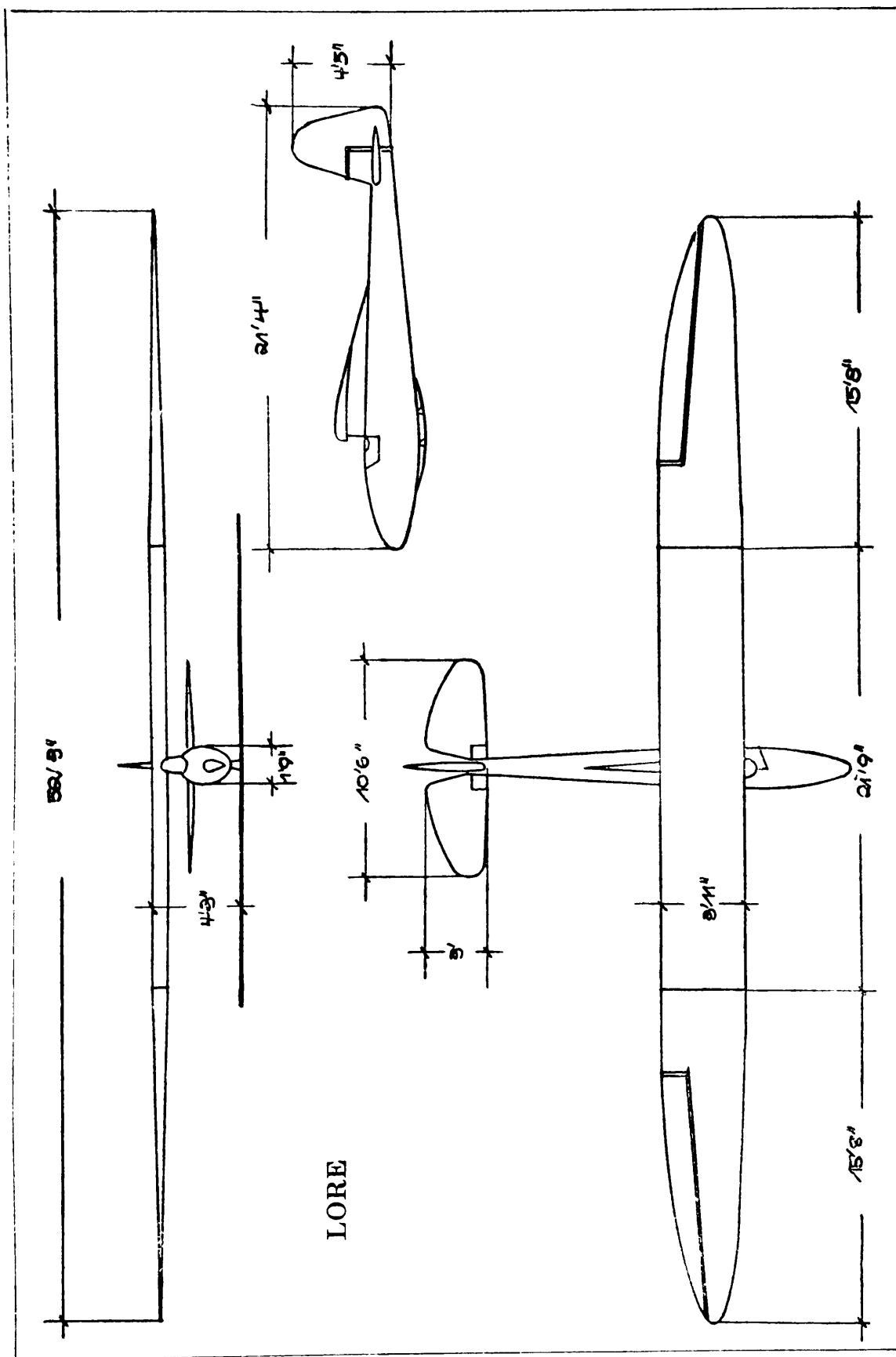

most other sailplanes. Like the "Westpreussen," it is entirely covered with plywood over three longerons and many bulkheads. The hind portion tapers off into a vertical blade which merges into a small vertical fin. The elevator is located upon a small tailplane built into the fuselage.

A cursory glance would hardly disclose any differences between the "Starkenbug" and its two predecessors. But the wing section is different, as is also the attachment of the wing to the fuselage, the construction of the skid and some details in the arrangement of the control surfaces. It is undoubtedly a better-made machine, but its most interesting point is the coupling of the rudder and ailerons in such a way that they work together without intervention from the control column. This coupling system has already been used in the "Konsul."

The successful sailplane "Luftikus," constructed by O. Hohmuth, is a development of the old "Vampyr." Looking at it, you think you have before you an improved "Vampyr." The wing is in three sections, with one spar, a straight middle section and triangular outer sections. It rests upon a fuselage neck and is braced against the upper surface of the fuselage by two steel tube struts. The fuselage itself is covered with plywood; the cross-section of the front and rear parts are respectively hexagonal and rectangular, the latter tapering into a horizontal blade which carries the elevators. The rudder is conspicuous by its high, pointed shape. The advantage of this type is that it is comparatively easy to build and combines cheapness with efficiency.

Alexander Lippisch struck out a line of his own when he designed the "Professor" for the Rhön-Rossitten Ges. This sailplane is intended to provide pilots who have passed their "C" test, with a machine upon which they can train for transition to sailplanes of the high-efficiency types. Solidity of construction is achieved by the struts which brace the rectangular middle section of the wing. The outer sections of the wing are triangular in plan form.

The wing has one main spar and a light auxiliary spar, while the struts take the torsion in the centre portion. The fin emerges from the rear end of the hexagonal fuselage, while the elevator has no stabilizer or tailplane. I made

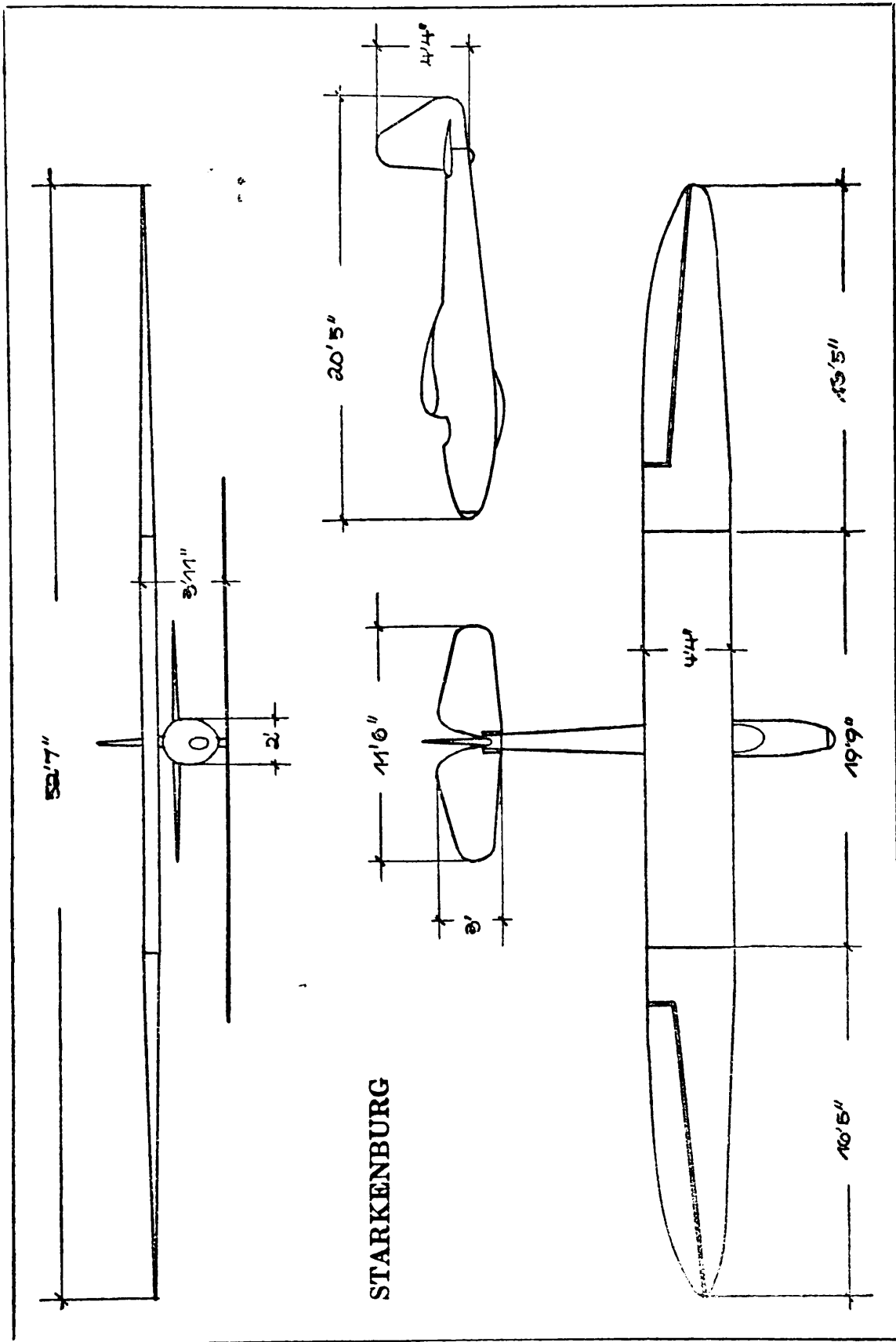

some successful flights in the "Rhönggeist," a sailplane of this type, in 1928 and so brought it into notice.

The sailplane which has hitherto proved most successful is the "Wien," with which three world's records for distance flights and two for height were achieved in 1929. It was designed for me by Alexander Lippisch and Emil Pohorille. In this sailplane certain constructive ideas emanating from the "Professor" type are cleverly developed. The aspect ratio is 1 to 20. The wing area is the same as that of the "Professor," but the span is sixty-three feet. To reduce weight, the wing is built in two parts instead of the usual three. It is rectangular in the middle and tapers sharply towards the tips. The ailerons are unusually large. Each plane has one main spar, with an additional light auxiliary rear spar, and is braced by Vee struts. The fuselage has an oval cross-section. As in the "Professor," the elevators are carried upon a revolving steel tube spar, which projects from each side of the fuselage. The special care bestowed upon the construction of this machine has made it practically the best and most reliable that has yet been built. In spite of its span and light weight it has repeatedly withstood exceptionally heavy stresses, many of which were far greater than those attained in normal soaring flight. Its flying qualities are equally good in stormy weather or in the lightest breeze in which it has been found possible to fly.

The "Fafnir" is worthy of special notice on account of the successful flights and records which Groenhoff made on it during 1930 and 1931. This design of Lippisch's was built especially strong and is therefore heavier than other high-performance sailplanes. The wing is cantilever. The wing section, Göttingen 652, becomes symmetrical towards the tip, the angle of incidence diminishing noticeably. The ailerons are very large. The small middle section of the wing is directly attached to the fuselage. Each plane has a marked dihedral angle near the centre section, while the outer portions are set at zero dihedral, although on the ground the planes appear to droop giving the machine the appearance of possessing a negative dihedral angle. The pilot's cockpit is completely enclosed, leaving only side

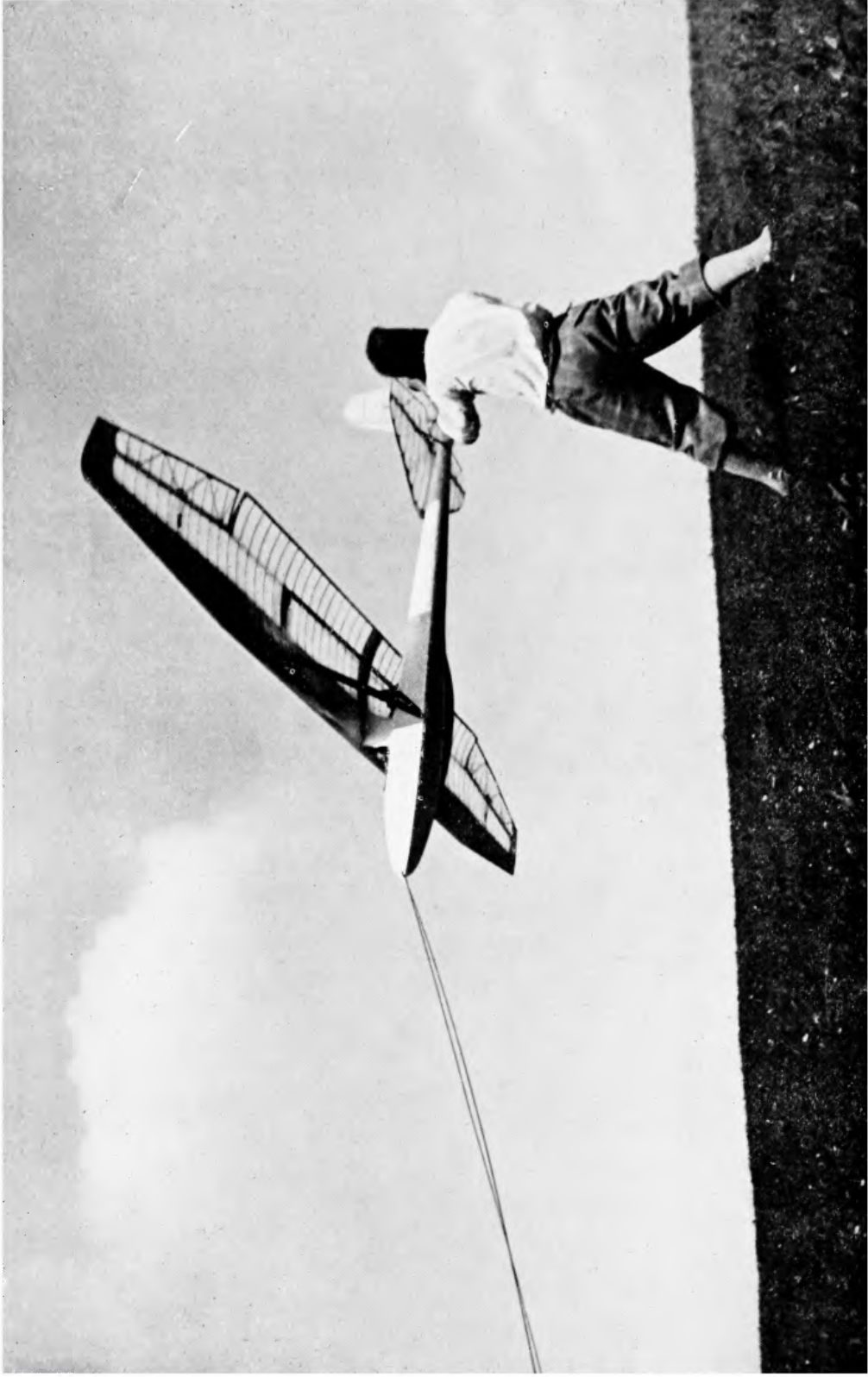

78. THE "RIÖNADLER," A DOUBLE-SEATER CONSTRUCTED BY ALEX LIPPISCH

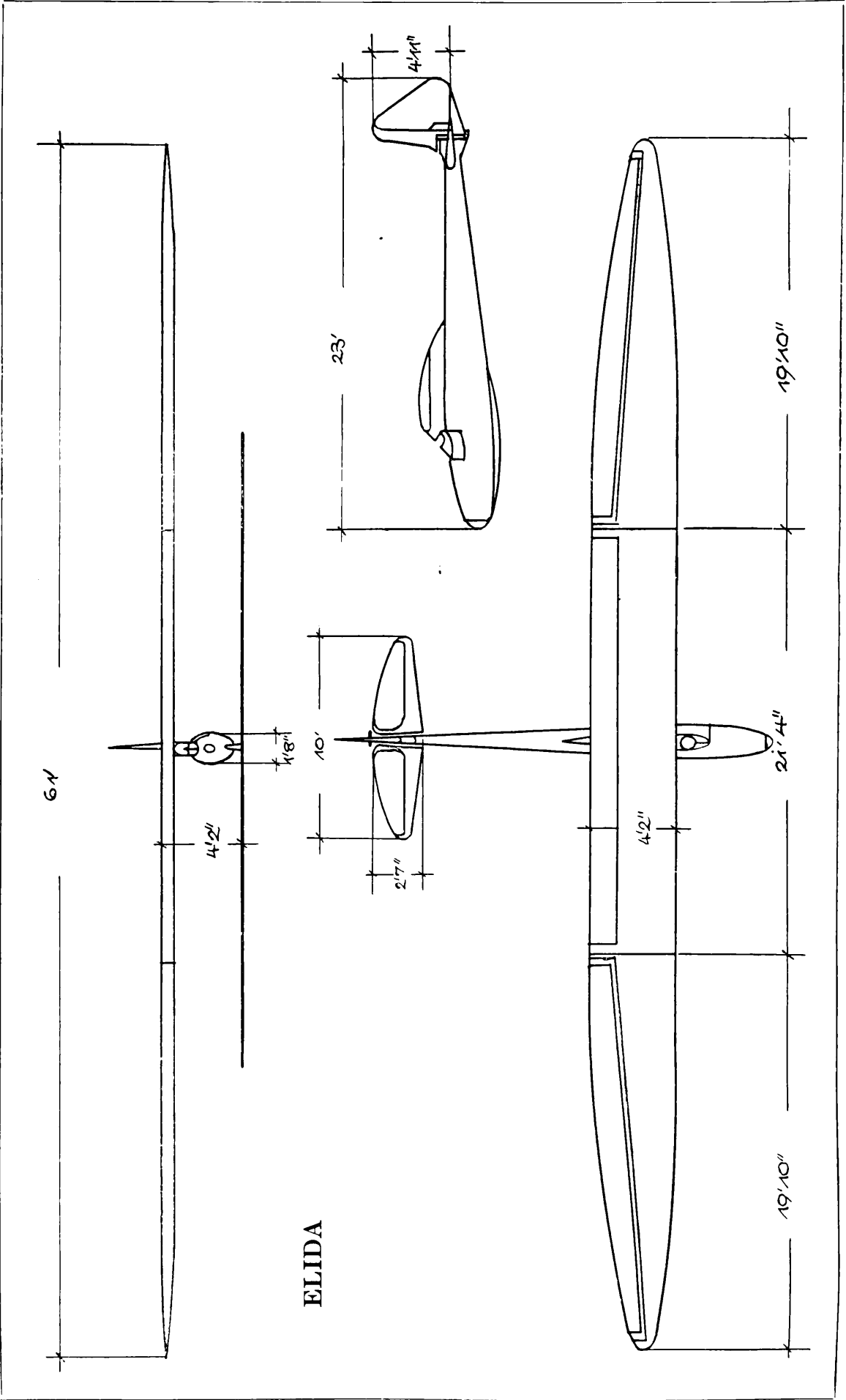

ELIDA

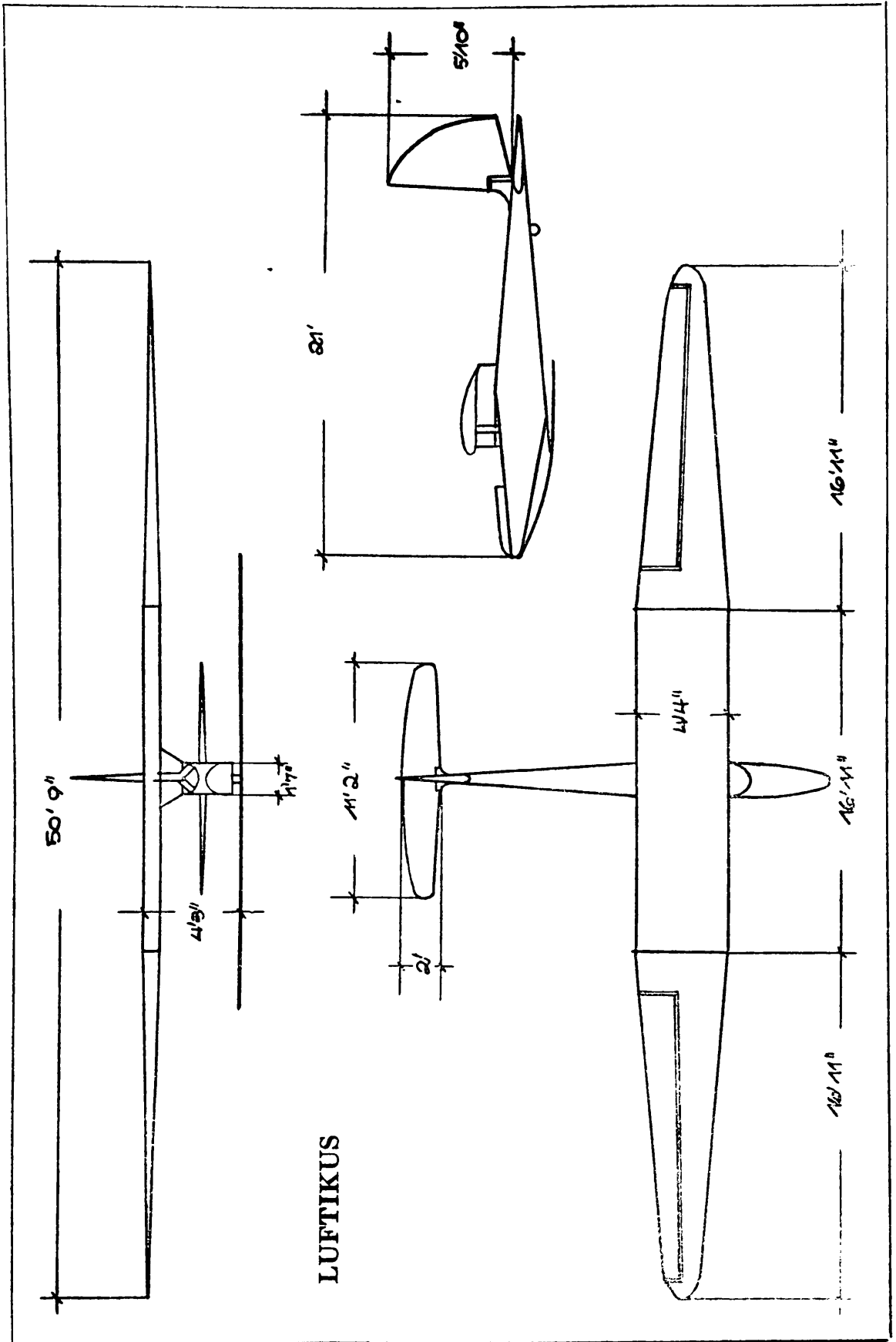

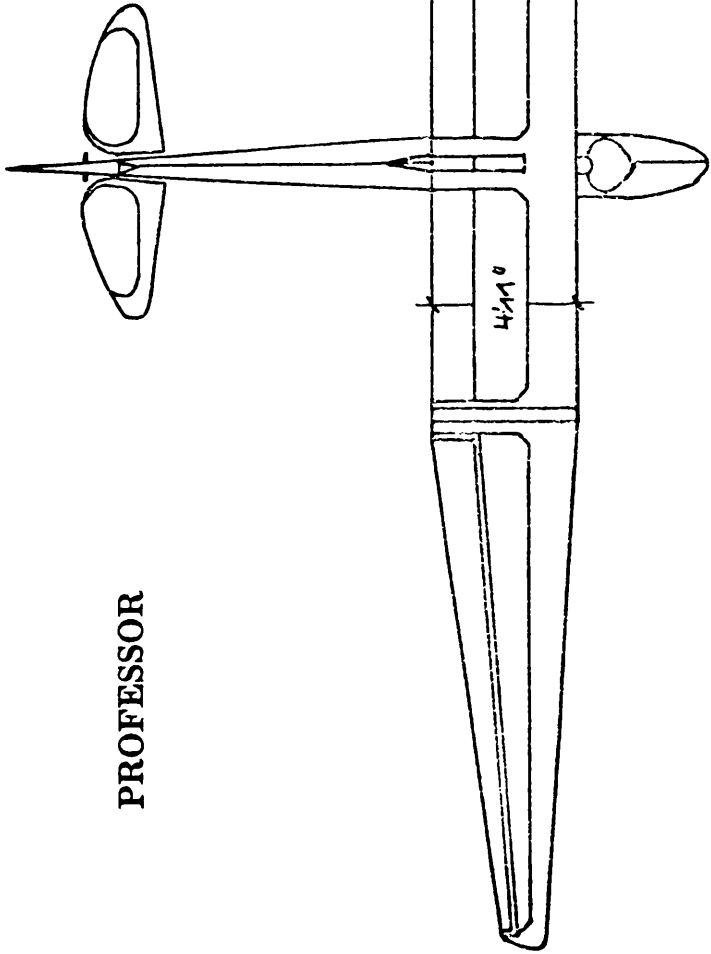
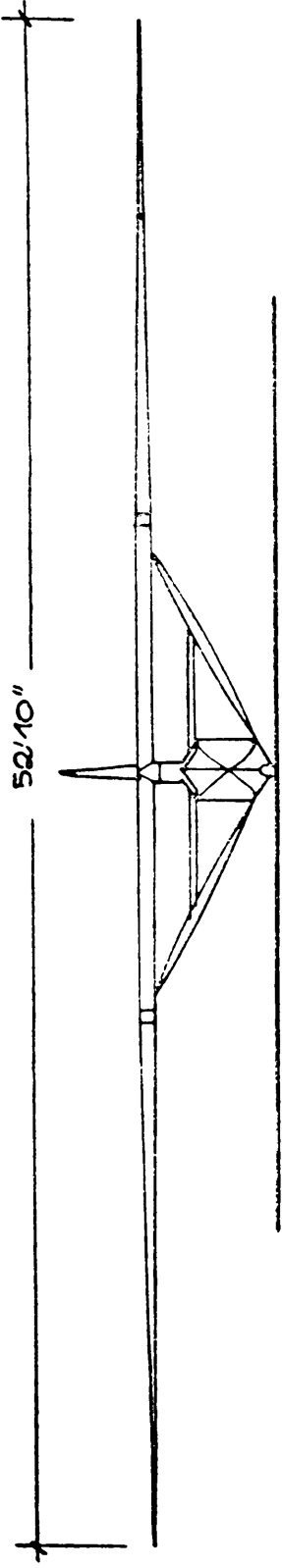

PROFESSOR

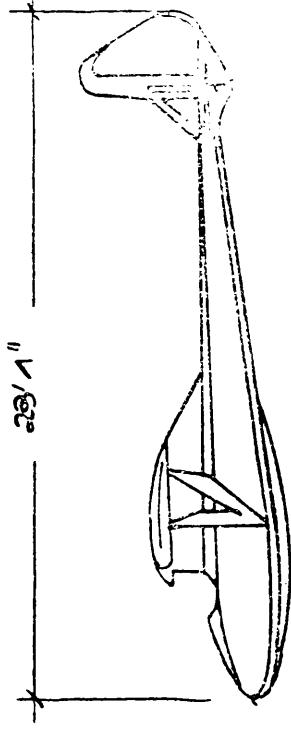

openings for his view. The "Fafnir" is equipped with a full set of instruments for blind flying such as Turn and Bank indicators. The fuselage and tail units are normal. Amazing controllability, which is far ahead of that of any other sailplane, has been obtained in this machine.

The prices of sailplanes naturally vary with their types and qualities. It is hardly possible to estimate beforehand what a new plane will cost, as so much depends upon the quality of the materials used and the peculiarities of its construction. While, for example, a machine with a large rectangular middle wing section needs a large number of ribs of equal size, the light firm tapering wing requires many more hours of work for the production of its innumerable ribs of different sizes. The employment of lightened stampings or "electron" fittings instead of steel ones saves weight, but is expensive. Hence the prices of the high-efficiency sailplanes which I have described above, vary from £150 to £300, the cheapest being the "Professor," while the "Wien" or the "Fafnir" is the most expensive. Between these lie the "Westpreussen," costing £190, and the "Elida," costing £200.

These prices do not include the instruments which are so necessary for modern expert flying, such as the air speed indicator, altimeter, compass, barograph, and the variometer which is an instrument that indicates the climbing and sinking speeds. The price of a parachute is likewise not included, but it is most advisable to carry one in a sailplane used for difficult thunderstorm and cloud flights.

An essential for pilots undertaking cross-country flights in high-efficiency sailplanes is a trailer upon which the machine can be brought home again. These are of different types, the most usual being the two-wheeled trailer which can be towed by a powerful motor-car. To protect their contents from rain and dust these trailers have canvas covers.

All this additional equipment increases the expense considerably, often by more than half of the actual price of the machine. Finally, there is the licence fee, for it will readily be understood that such high-performance sailplanes can only be entrusted to pilots possessing very high qualifications.

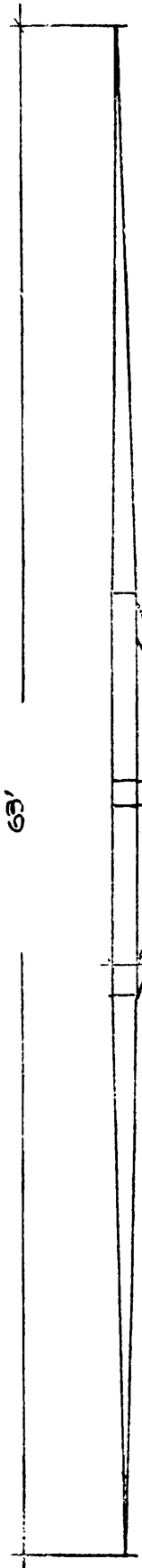

63'

41' 11"

2'

18' 4"

2' 10"

25' 10"

KRONFELD'S WIEN

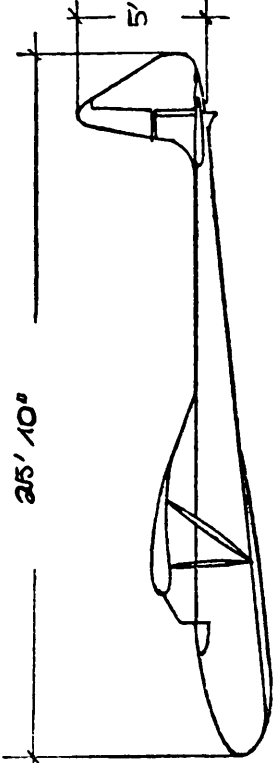

17'

4' 11"

23'

23'

5'

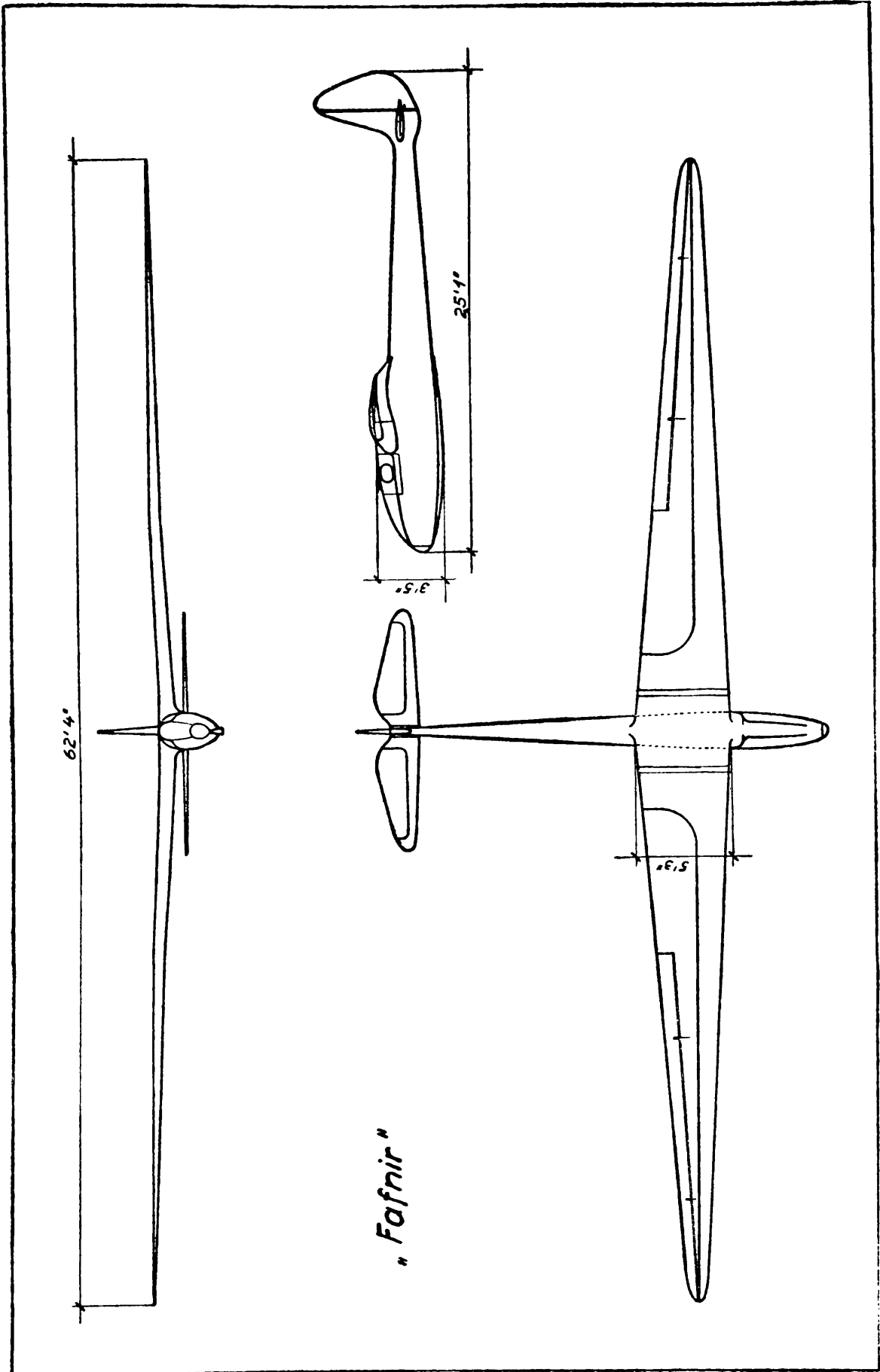

"Fafnir"

Every sailplane factory has developed a family of its own types. Among the German ones let me quote those of, undoubtedly, the largest sailplane and glider factory in the world. This is the former "Kegel Flugzeugbau" in Kassel which has now been taken over by Fieseler, the German stunt pilot. The most important point regarding the products of this firm are the low prices, which have been made possible by the splendid organization of the works. Besides machines similar to the "Zögling" and "Prüfling," and the two-seater "Hercules" which I have already described; two types deserve special mention, namely:— the "Kassel 20" and the "Kassel 25." The only difference between the two machines is the wing, which is mounted on the same fuselage with the same controls. The "Kassel 20" has a span of 46 ft. 2 in. and a length of 21 ft. 1 in.; a maximum chord of 3 ft. 9 in. and a wing area of 165.75 sq. ft. The weight, empty, is 225 lb. This machine can be called a further development of the "Prüfling," with differential control provided for the ailerons.

The "Kassel 25" only differs as regards the span, which is 59 ft., the wing, however, possesses the same chord as the "Kassel 20" making the wing area 166.75 sq. ft. The weight empty is 230 lb., and this is surprisingly low. During the Rhön competitions of 1931 this machine showed good flying qualities which might be accounted for, to a large extent, by the differential control of the ailerons. It is, at all events, an outstanding example of a high-class, and at the same time not too expensive, sailplane. The price of the "Kassel 20" is £49, in Germany; and that of the "Kassel 25," £78. This deserves special mention as nothing is more important for the popularization of soaring flight than keeping the price for the products of reliable firms as low as possible.

I imagine that I have said sufficient to indicate the direction in which we may look for further development in the building of high-efficiency sailplanes. I myself find the questions connected with this development so deeply interesting that I have not been content with seeking for new ways of actual flying, but have also occupied myself with the design side in the hope that I might be lucky enough

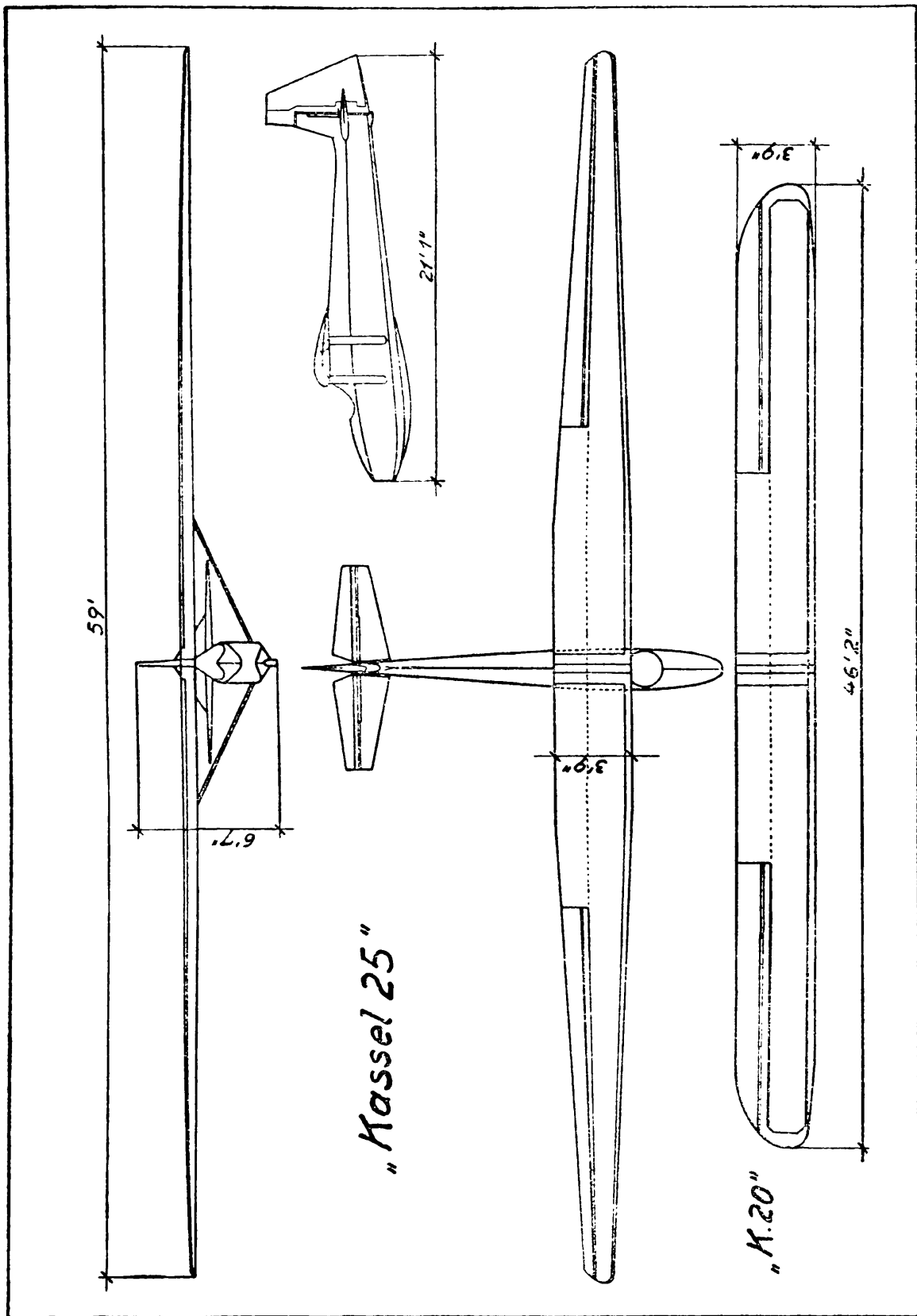

to make some contribution to the development of the sailplane of the future. I worked on the theory that any marked improvement in efficiency could only be through a proper wing section in conjunction with a suitable span and aspect ratio. Careful calculations have shown that an increase of these results in a decrease of sinking speed, a better gliding angle, and a greater range between maximum and minimum flying speed, while at the same time it helps towards the attainment of greater stability. Such innovations will greatly increase the chances, on a cross-country flight, of reaching many up-currents which could not be reached by sailplanes of another type, and also of soaring in districts where the up-currents would be too light for other machines. My latest machine which Dr. Kupper, of Munich, the designer of the "Kakadu," designed for me on these principles and which was built by the "Fieseler Flugzeugbau" at Kassel, should show a thirty per cent. all-round improvement in flying qualities. This is a remarkable achievement in view of the fact that the difference in quality between the other sailplanes at present in use is practically negligible, even those which show the best practical results being but little superior to their rivals.

The argument against such an increase in span over the dimensions which have hitherto been proved feasible is, of course, that it will inevitably increase the difficulties of flying. Naturally both the danger of crashes and the expenses are considerably increased, but all such drawbacks can be overcome by increased flying efficiency. It is a mistake to expect only the beginners to learn; expert pilots must also train themselves to fly these special machines.

This latest machine of mine, which came out in the spring of 1930, has a span of 99 ft. The wing has very pointed tips and a pronounced camber; it is built in four parts. The ailerons run the whole length of the wing-surface. To obviate any possibility of jamming which might be caused by the great flexibility of this cantilever wing, the ailerons are divided into six flaps and are operated separately. Like the rudder and elevators, these are constructed of steel tubing covered with fabric and hinged on ball-bearings. The surface of the wing itself is entirely covered over with



80. THE "KAKADU" FUSELAGE ON THE SLIPS
(Munich Academic Flying Group)

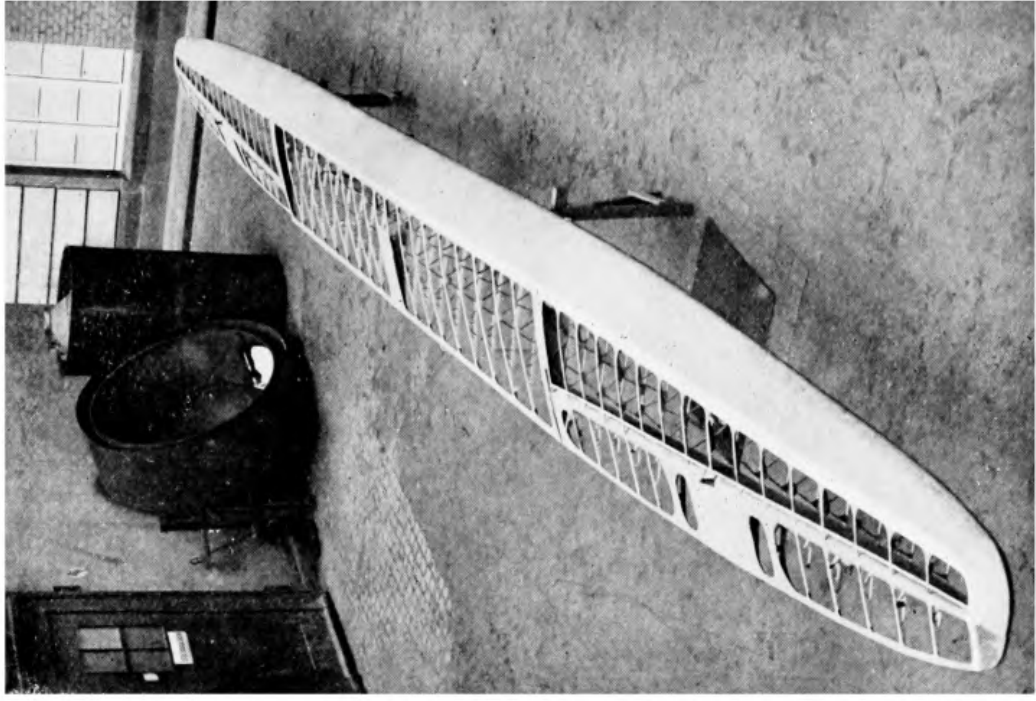

81. THE TRIPARTITE, ONE-SPARRED WING OF A
HIGH-EFFICIENCY MACHINE



82. A COMPETITION ON THE WASSERKUPPE. ON SUCH OCCASIONS AS MANY AS TEN MACHINES MAY BE SEEN FLYING OVER THE SAME SLOPE

Facing page 287

highly-varnished plywood, while all gaps between the fixed and moving surfaces, and in particular the ailerons, have been carefully eliminated.

COMPARATIVE SIZES OF WELL-KNOWN SAILPLANES

VAMPYR
WIDTH OF SPAN 41' 5"

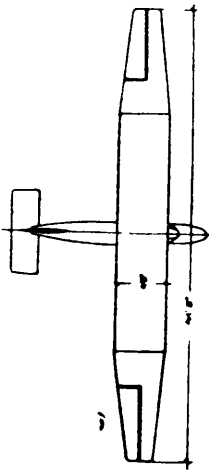

WESTPREUSSEN
WIDTH OF SPAN 52' 8"

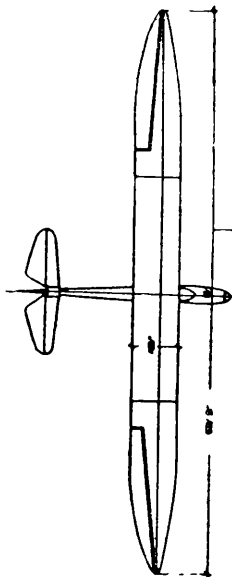

KRONFELD'S WIEN
WIDTH OF SPAN 63'

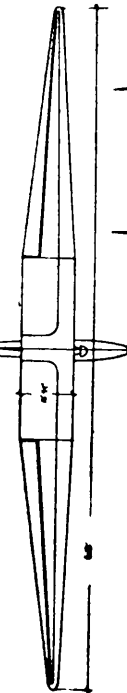

KRONFELD'S GIANT SAILPLANE
AUSTRIA
WIDTH OF SPAN 98' 10"

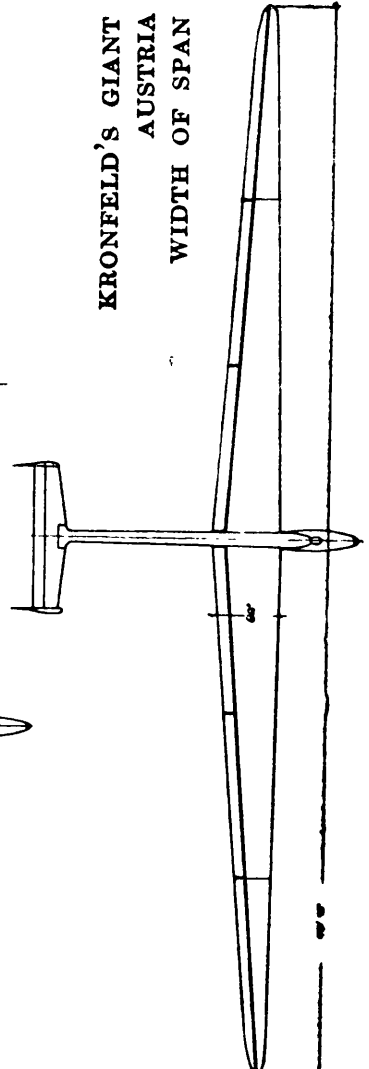

The rudder is composed of two parts, each of which is affixed with its fin to the outer ends of the tailplane. By a special arrangement it is possible to move the two rudders

KRONFELD'S GIANT
SAILPLANE
"AUSTRIA"

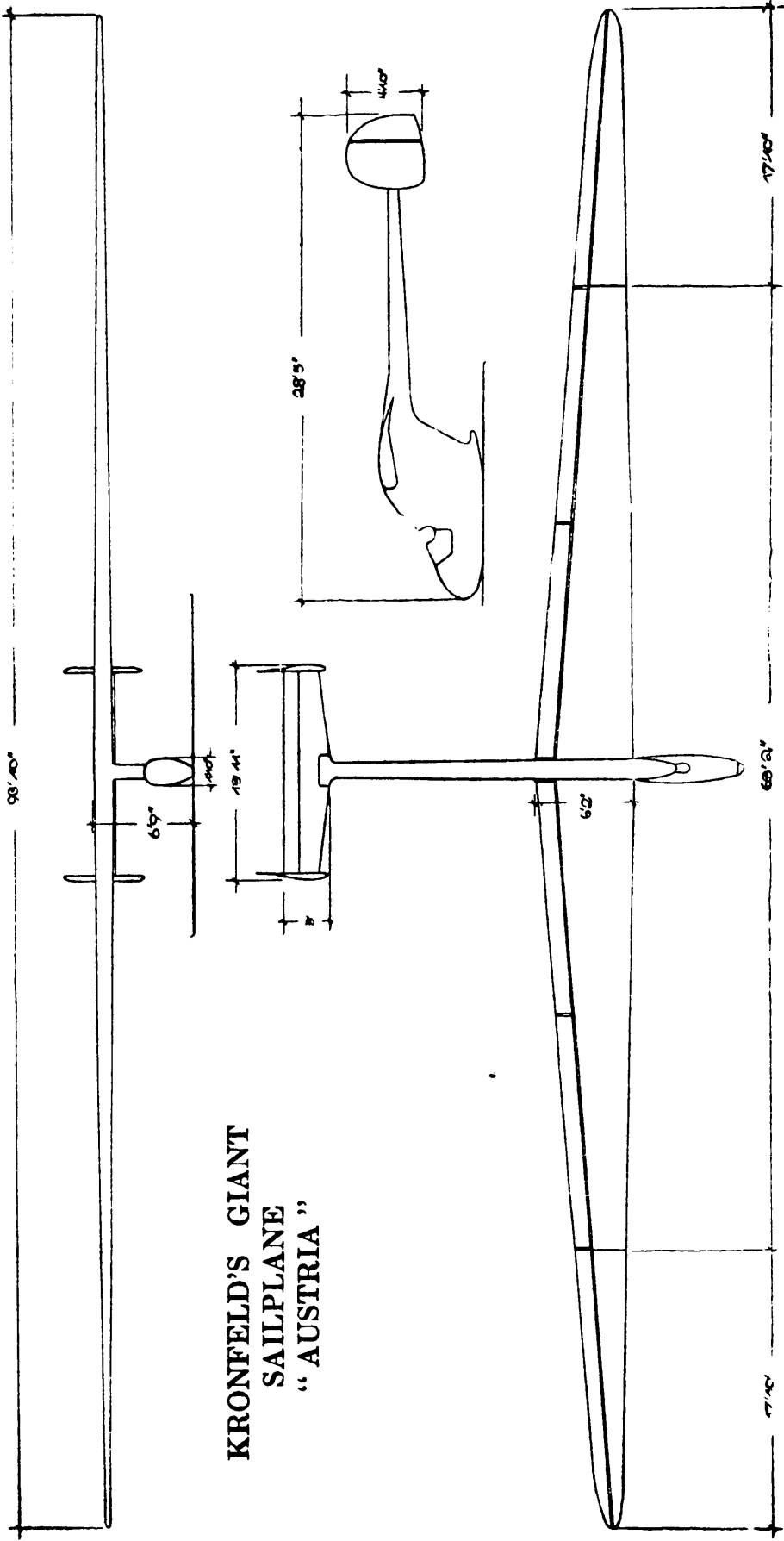

in opposite directions by means of pedals, and thus to have an exceedingly effective air brake which enables the machine to be landed in restricted spaces in spite of the immense wing span, with the consequent flat gliding angle.

Another novelty in this sailplane is the variable wing camber. This is obtained by an arrangement of the continuous flaps, enabling them all to be raised or lowered together.

It yet remains to be seen what this machine will achieve. In every way it is an experiment, the cost of which shows an enormous increase over that of earlier sailplanes, amounting, in fact, to four times that of the "Wien." I am, therefore, more or less justified in expecting that the achievements of this soaring giant will surpass those of its forerunners.

The construction of gliding and soaring planes is work which requires great experience, special talents and much knowledge. A whole book could be written about the experiments and successes in this department. One thing is certain, however, that if the development of the instruments upon which the flying virtuosi play, keep pace with the latter's own ability and knowledge, soaring flight still holds many surprises in store for us.

WEATHER, WIND AND CLOUDS

ONE of the most interesting of natural phenomena is the weather. Weather lore (meteorology) is a comparatively youthful science.

This seems to be a contradiction in terms because the human mind always gives its first attention to those problems which stimulate it most. But the fact is that the most important manifestations of the weather present such extraordinarily difficult problems that we have only just been able to make efficient researches concerning them. Fleeting as the wind are all the consequences which it brings with it ; moreover, before the discovery of flight it was hardly possible for us to force our way into the kingdom of wind and weather—the air ocean—in order to weigh and measure it.

Soaring flight has done its part in showing the need for intense research. It spreads the knowledge of weather lore far and wide because everyone who is in any way connected with it realizes how dependent upon the weather and its laws we actually are.

Various kinds of meteorological research are to be differentiated according to the sphere of their operations. The latest branch of meteorology is that pertaining to flying, which has become of the utmost importance for aerial traffic. The aspect of meteorology which I wish to discuss here may be termed the meteorology of soaring flight, so that this chapter will only deal with the phenomena which are of immediate importance to us soaring pilots.

A knowledge of the laws of heat and motion will enable us to understand weather phenomena.

We owe the warmth of the earth's surface to the varying degrees of heat emitted by the rays of the sun. Everyone knows that when the sun beats down on an open, bare dune or moor we find the wood to which we turn for refuge pleasantly cool ; it is hot in the cornfields, cool on

THERMAL UP AND DOWN CURRENTS

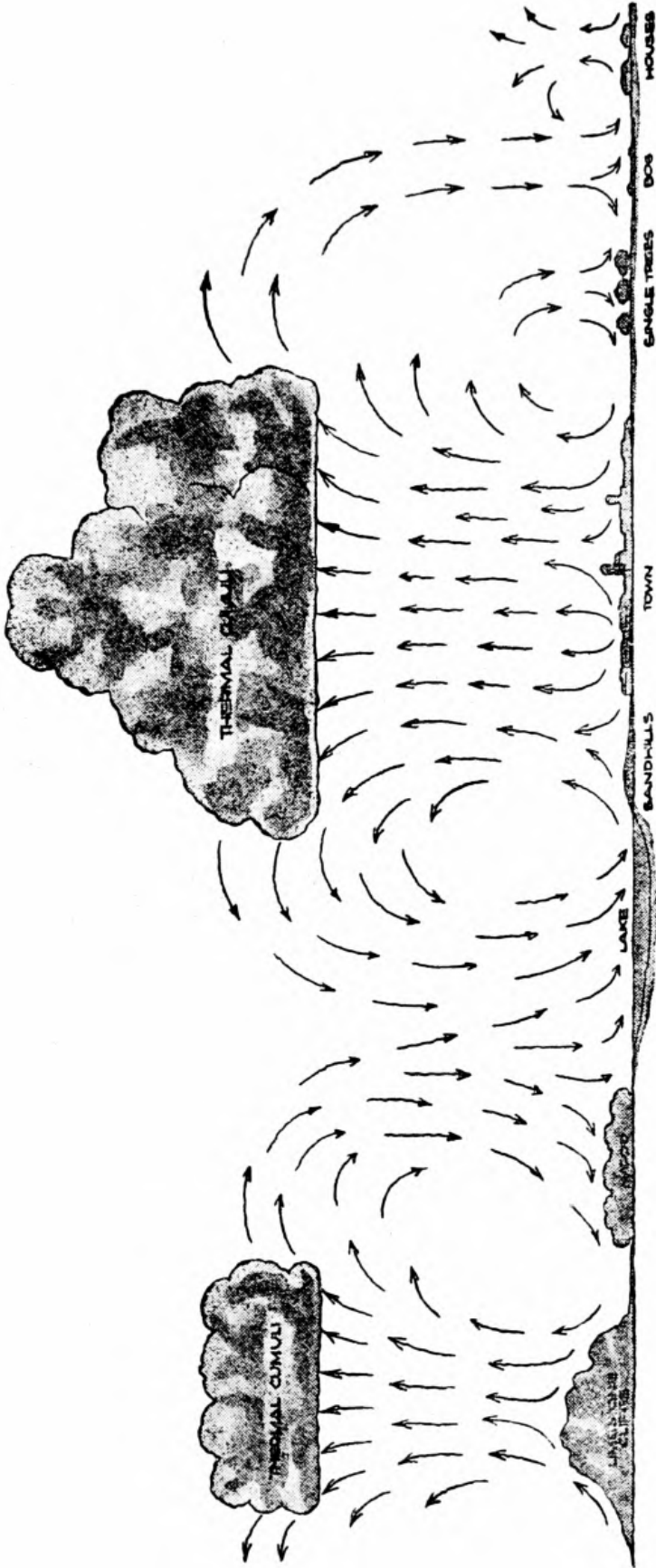

A. KRONFELD

the water. The warmth imparted by the sun to the earth differs in its nature according to the latter's characteristics, and the earth imparts its heat to the layer of air immediately above it. This causes movement in an atmosphere which had previously been at rest. This movement is visible ; on a hot day we may see the air shimmering around a house wall which lies bathed in hot sunshine ; as boys we placed light paper parachutes in this hot stream to watch them float upwards. Over cool spots the air sinks, and thus currents are formed.

Hot air is lighter than cold. Great expanses of high pressure and low pressure, as the meteorologists term them,

SMOKE FROM A CHIMNEY SHOWS THE TURBULENCE OF THE ATMOSPHERE

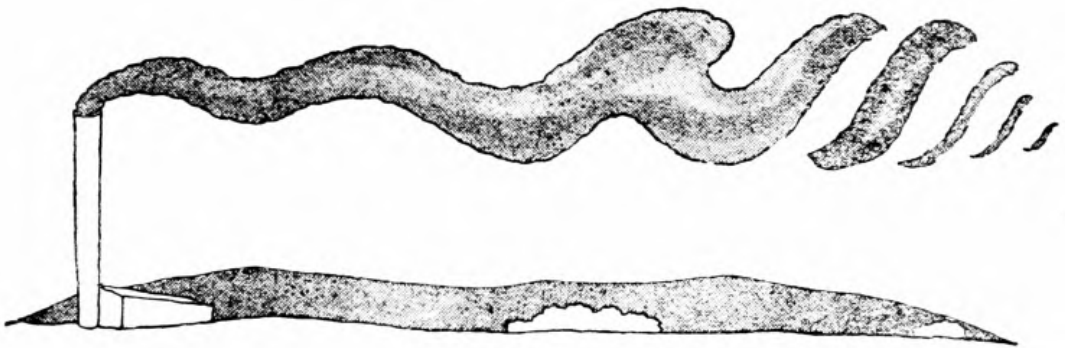

R. KRONFELD

are formed. Owing to the revolution of the earth the air within these areas of pressure acquires a rotary movement, and travels across the earth's surface on a vertical axis.

We must now take into account the moisture contained in the atmosphere. Warm air absorbs more moisture than cold. This also we know from daily experience.

When it is cold outside, the window pane grows misty. What is the reason of this ? The warm air within the room, which is saturated with moisture, is cooled by contact with the cold glass and compelled to liberate a portion of the water it contains. This settles in tiny fine drops upon the pane and dims the glass.

All of which is, of course, not quite so clear and simple in reality as it appears in this example, but it is near enough for our purpose.

The primary need of the soaring pilot is wind. This flows from the regions of high pressure to those of low pressure, but the obstacles on the earth's surface divert its even course. We can watch the formation of currents created in this way in the air by observing the water of any river with crooked banks. Even minute irregularities lead to the formation of little eddies, some of which remain whirling in one spot while others break away and wander

CURRENTS ON DETACHED ELEVATION

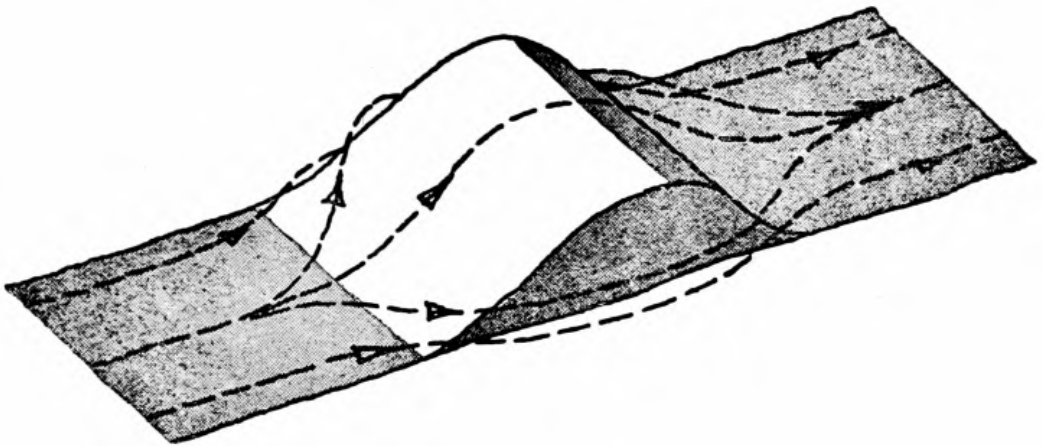

COURSE OF CURRENTS MAINLY ROUND THE HILL, HENCE
LITTLE UPWIND

on with the stream. Such eddies in the air are formed above the earth's surface by woods, houses, hillocks and valleys, and thus there extends for a considerable height above the earth's surface a zone of irregular currents and billow-like fluctuations which we may call (to borrow a comparison from the ocean) the zone of atmospheric surf and breakers. If we observe the smoke rising from a factory chimney, we shall see it rolling along in waves, which often grow larger and larger until they resolve themselves into separate eddies. Very similar phases are to be observed in the cloud ocean ; these formations, which correspond

to the ocean's breakers, accommodate themselves to the currents. This zone of surf and breaker-like activity generally extends to a height varying from six thousand five hundred to ten thousand feet above the ground.

When the wind encounters an obstacle, it has to give way. If a tower or a low hill rises from the plain, the wind's simplest way is to go round it. If, on the other hand, a long chain of hills crosses the wind's course, it must go

CURRENTS ON HILLSIDE

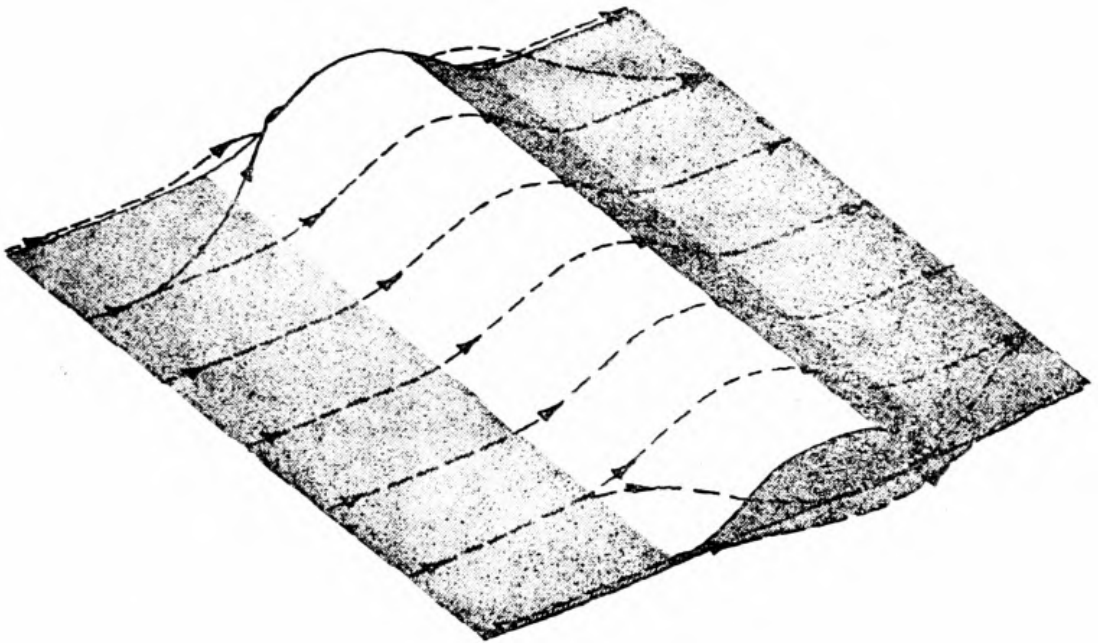

COURSE OF CURRENTS MAINLY OVER THE HILL, HENCE
MUCH UPWIND

over it. If we keep our eyes open, we can observe these natural phenomena every day and note all the various ways in which currents are formed. In a snowstorm there is generally a patch free from snow behind any isolated obstacle, showing the path of the wind around it. From the course of the snowflakes round the corners of houses, over roofs and past any obstacle, it is possible to acquire knowledge which can be put into immediate practice on a larger scale when soaring in the high mountains. In summer we may ascertain the direction of the breeze from

dust, the rustle of the leaves, or from the butterflies fluttering along with it.

Before a straight wall opposing the direction of the wind we often find small heaps of dust parallel with it in summer and of snow in winter. These show us where the wind is forced to leave the earth in order to climb over the obstacle. In the space between the obstacle and the heap we find a windward eddy, while on the sheltered side a similar eddy is formed. This latter is known as the leeward eddy. Both these types of eddies can prove a danger to soaring and other pilots ; if they are strong enough they can produce up-currents in localities where we expect down-draughts and vice versa.

The velocity of the wind increases when it has to climb over obstacles. The height to which the disturbing influences of a range of mountains extends and the distance before it at which the air currents begin to rise from the ground and touch it again on the farther side have been repeatedly observed and measured. As a rule all such measurements show a marked increase in proportion to the height of the mountains and the strength of the wind. Here are some approximate results of such measurements :

Height of mountain	2,650 ft.,	sphere of influence	925 ft.
" " "	4,950 "	" " "	1,300 "
" " "	8,250 "	" " "	2,150 "
" " "	11,000 "	" " "	3,300 "

A single measurement showed that a region of down-draught extended for a distance of thirty-three miles on the lee side of a mountain ridge eight thousand two hundred and fifty feet high and a distance of seven and a quarter miles on the lee side of a mountain of two thousand six hundred and fifty feet. The facts apply to the positions of the uprising currents in front of the mountains. All this is of the utmost importance to pilots undertaking long soaring flights.

If, on the contrary, the wind blows across two ridges lying comparatively close to one another, the whole valley between them is usually filled with swirling currents above which the main stream passes on evenly. If the pilot is

STREAM OF CURRENTS ON SLOPES

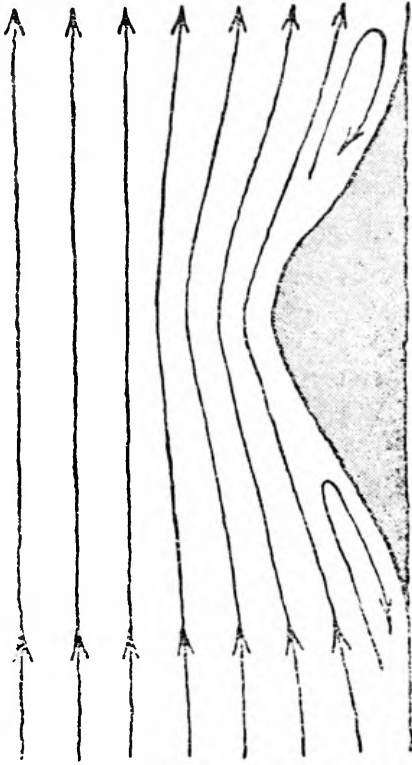

WINDWARD EDDY
LEeward EDDY
STEEPER SLOPES PRODUCE EDDIES TO WINDWARD
AND TO LEEWARD

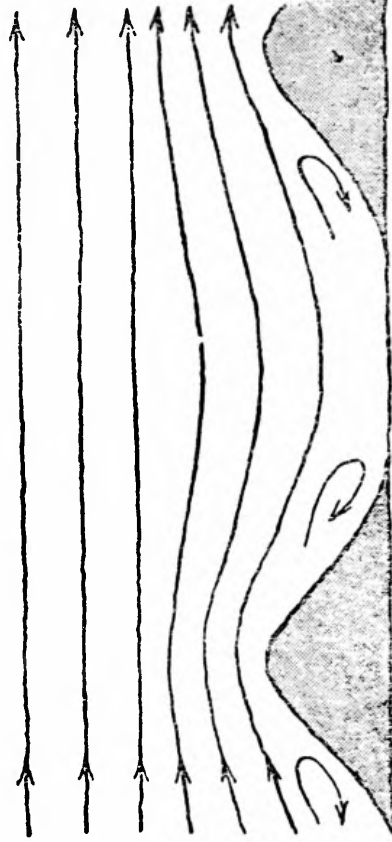

TWO HILLS FARTHER APART EACH PRODUCE ITS UP
AND DOWN CURRENTS

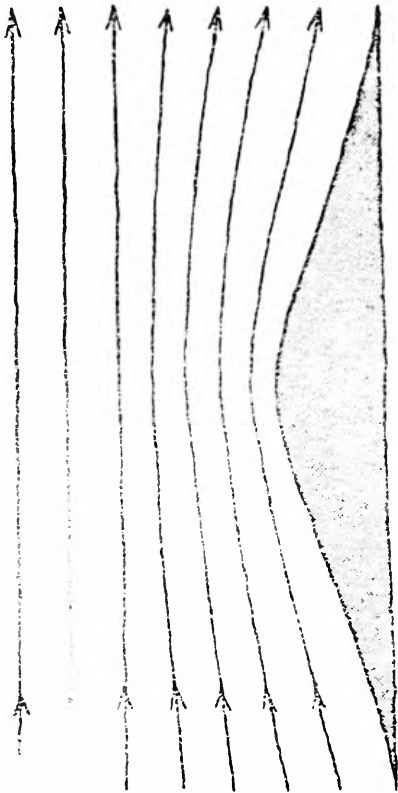

SIMPLE UP AND DOWN CURRENTS ON A MODERATE
SLOPE

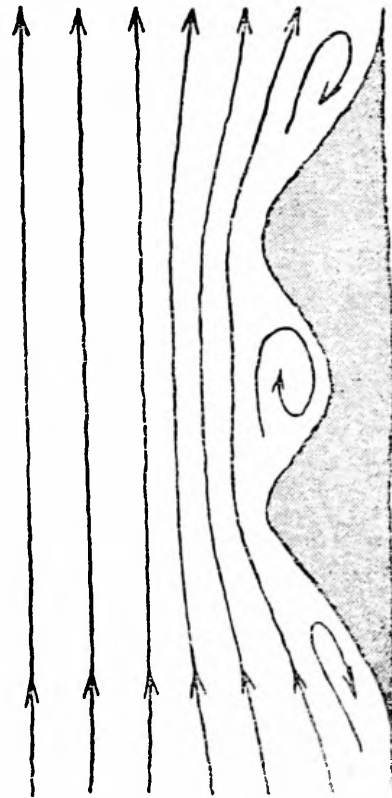

TWO ADJOINING HILLS PRODUCE SIMILAR CURRENTS
TO ONE HIGHER, OWING TO THE FILLING UP OF THE
VALLEY BETWEEN BY AN EDDY

high enough up, the influence of the disturbance will be quite unnoticeable.

Similar phenomena are to be remarked on coasts. Whirling currents are created on the shores where the sea meets the land in a fashion similar to that in which they are formed above the mountains where the wind is forced to climb, but here they are caused by the difference of the friction between air and water and air and land. Pilots have frequently noticed this fact.

It has already been shown that clouds and cloud formations can indicate up and down winds. Therefore we must inquire into the origin of clouds ; as a rule they are produced by the condensation of aqueous vapour. When this vapour cools, its moisture collects into fine drops, as we have already seen. This process is called condensation. Aqueous vapour, as such, is invisible, but as soon as these fine drops are formed and hover in the air, they become visible in the form of mist, fog or clouds.

When warm air which is saturated with moisture rises, it passes into colder regions. At that height at which the temperature necessary for precipitation is found, cloud formation begins. The cloud then builds itself up above its base until all the moisture is condensed. Thus every cloud is for us a natural indicator of an up-current. On the other hand clouds dissolve when they descend into lower, warmer layers where the tiny drops of water expand again and become invisible. The cloud is then dispersed. Clouds in process of formation are round and globular ; those which are dissolving are ragged and straggling. These latter show the presence of down-draughts. Although the many varied phenomena of cloud formation can all be explained in this way, the variety which is most interesting to the soarer is the cumulus, a form of cloud prevalent on hot summer days.

It is essential for us to rid ourselves of any conception of the clouds and of cloud formation as permanent objects. A cloud is not a moveable piece of scenery that can be pushed, so to speak, across the heavenly stage ; not even the tiniest fragment of a cloud ever remains still, and all cloud matter is in a continual process of evolution and dissolution.

CUMULUS PRODUCED BY WIND EDDIES

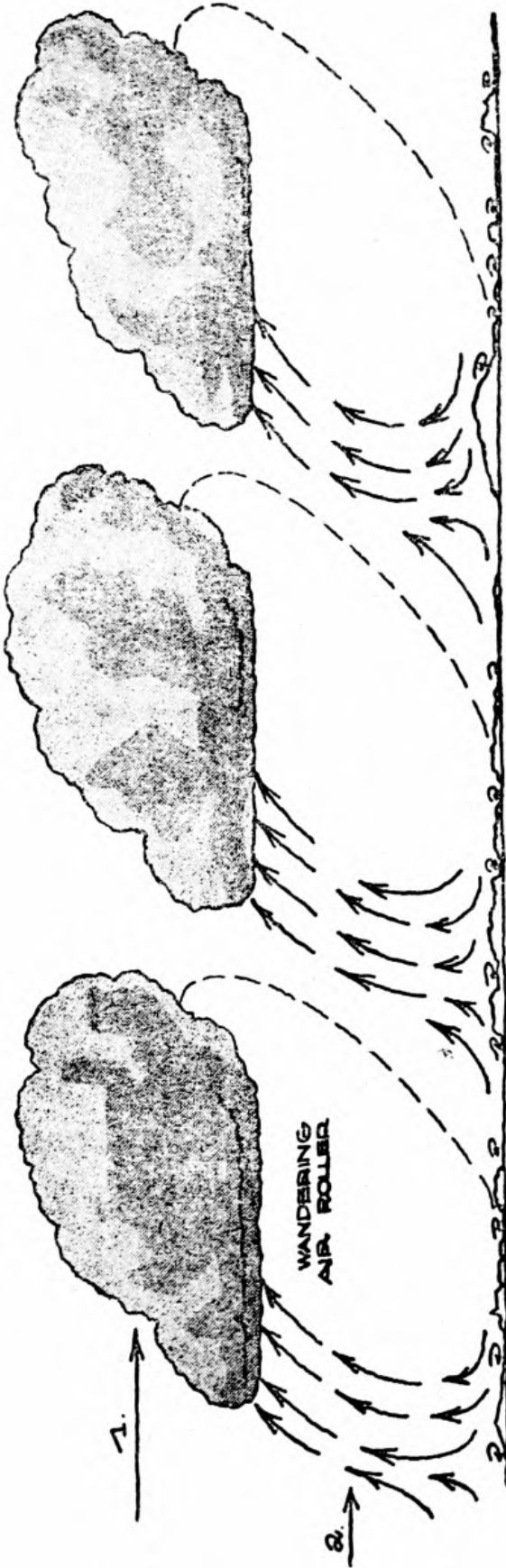

RETARDING EFFECT OF GROUND

- 1. HIGH WIND VELOCITY
- 2. LOW WIND VELOCITY

We have seen how rising air currents are produced. When such a body of air is in movement, it draws up with it all the surrounding particles of air, and thus a kind of chimney is formed, which is capped at its summit by a cloud. As there is a continuous upflow of air, new particles constantly condense on the lower edge, rise and, after yielding their moisture to the cloud, climb invisibly higher. This is the thermal process of cloud building, in which heat is the sole creative factor.¹

The second way in which the clouds come into being (a process frequently found working in combination with the first) is by means of swirling currents or turbulencies. By the example of smoke from a chimney we have seen how the air is formed into whirling currents. In this way a thick belt of air may be filled with large eddies whirling upon a horizontal axis and rolling forward with them across country. To obtain a clear picture of this phenomenon, let us imagine the movements of a steam roller proceeding along a road. If we look at it from behind, the roller moves upward ; if we view it from in front, we perceive a downward movement. In a similar fashion our "air roller" moves over the land, but with every revolution a chain of the clouds known as cumuli forms on the rising side. These are the best clouds for soaring purposes, especially when the rising branch of such a cloud meets a thermal chimney and is strengthened by it.

It is also conceivable that such air rollers may move over the land without containing sufficient moisture to produce condensation or without rising into a layer cold enough to cause it. In such a case there will be an up-current, which will be invisible to us. That is why soarers love clouds ; they are the most infallible up-current indicators.

Clouds are formed wherever there is a strong up-current. When the wind blows off the sea on a long stretch of coast, we often observe a cloud formed by up-current hanging high above the edge of the land. In all mountain regions similar clouds are to be found in windy weather. They point out to us the up-current field.

¹ As a matter of fact the explaining of the character of the cumulus is not quite as simple as described above. There are thermo-dynamic reasons for the condensation proceeding by its own accord when once started.

The dimensions¹ of the spheres of influence exercised by mountains upon the movements of wind are largely determined by observations of cloud formation. On the other hand there are gaps above the downwind fields in cloud masses of fairly regular formation ; from the size of these it is possible to measure the extent of the downwind area. The sinking air is warmed, the fine particles of water contained in the cloud dissolve and become invisible ; the cloud disperses and the weather clears up. This is the reason why tracts of land lying on the down-draught side of high mountains usually enjoy cloudless and beautiful weather. On the other side of the mountain, however, where we find the up-current field, clouds are likely to become over saturated owing to the constant accession of fresh moisture from the plain below. There are then so many particles of moisture in the air that it cannot sustain them all ; some begin to sink, carrying others with them on their way, and fall to the earth as rain. There is always much rain on the up-current side of mountains. By means of annual rainfall measurements in certain places it is easy to ascertain where the influence exercised by the mountains on the wind begins, for this is the point at which most rain falls. We may also see in our rivers an excellent point of comparison with those clouds arising over mountains as the result of great up-currents. If a rock juts out from a river bank into the stream, the water will be turned aside by it, while behind the rock, in the direction of the course of the stream, a small patch of white foam forms. In the process of cloud formation the earth would correspond to the river bank, the mountain to the rock, the air current to the flowing water and the clouds themselves to the foam continually forming and dispersing at the same spot.

If we are to believe the latest findings of meteorology, clouds are formed on a large scale on the boundaries between warmer and colder bodies of air. There are mighty masses of cold air in the polar regions and warm air above the temperate zones and the tropics. Atmospheric conditions throughout the world are said to be affected by the interpenetration of these masses of air, which do not flow evenly

¹ See p. 295

past each other but meet and interlock on their borders like the teeth of a cog wheel.

We have spoken of the zones of low pressure which drift over the earth in the form of gigantic tracts of whirling air. Each of these forms together with its corresponding zone of high pressure an aerial pair of cog wheels. In every zone of low pressure formed mainly from the cold air will be found a wedge or section of warmer air. The latter rises slowly above the cold air, which exerts violent pressure underneath it and flings it upwards. On both sides of this movement clouds are engendered.

In order to obtain a clear idea of such an area of low pressure let us imagine a circular slab of some plastic material, such as clay or soft wax. Out of this we cut a wedge-shaped piece. Now we enclose the slab in a deep metal ring and fill in the gap with some softer material such as soapsuds, starch or some kind of paste. If we now press this whole model together by contracting the metal ring, the soft mass inside the gap will seek to escape. As it will be prevented by the metal rim from overflowing beyond the slab, it will climb up the cut edges of the slab and then spread itself over its surface. If we now draw on the surface of the slab little arrows in the opposite direction to that in which the hands of a clock revolve, set the slab rotating, and at the same time push it over the table from left to right, we have a rough model of such an area of low pressure drifting across the earth's surface.

To apply this parallel to nature we must think of the circular slab as cold air which, according to the extent of the area of low pressure, may spread over considerable tracts of land, sometimes even over whole continents. The little arrows show approximately the direction of the wind ; the movement of the slab from left to right corresponds to the movement of such an area of low pressure from west to east, while the material with which we have filled the gap represents the warm air. On the bordering surfaces between the cold and the warm air, that is to say, on the two cut edges, where the softer stuff overflows, the clouds pile themselves up.

In reality the conditions are such that the slant of the

inclined planes between the layers of air on the edge of the sector which advances first is only a slight one. Here the air streams quite slowly and gradually up over wide spaces, but when the area of low pressure has passed by, groups of little white clouds are formed high up. These cirri, as the meteorologists call them, float over the clear sky, and gradually a high cloud ceiling spreads itself out beneath them, whereupon visibility becomes bad owing to the increased dampness. Now the first rain clouds approach, the whole sky grows grey and a steady rain begins to fall. In the monotonous grey of the sky, cloud formations can no longer be distinguished. As soon as this first edge of the sector (the warm front) has passed the point of observation, the weather changes. We pass into the region of warm air ; the rain ceases, and the temperature grows warmer. Now the second front (the cold or gusty front) approaches. Cold air presses strongly under the warm air and flings the latter up sharply. We recognize this phenomenon by the fact that once again high clouds appear, under which mighty black cloud masses move along with great rapidity. The wind, which had been blowing from the east, south-east or south, changes suddenly to the west or south-west, heavy rain begins to fall and the temperature drops sharply. The wind velocity increases rapidly and violently ; the barometer, which has hitherto been falling, rises suddenly ; the squall front passes over us, sometimes accompanied by a thunderstorm and always discharging heavy showers. Gradually the rain ceases, the clouds begin to part, from time to time ever-decreasing fragments of front approach until at length we find ourselves upon the rear side of the low pressure. Beautiful, grand cumuli move across the sky when the area of low pressure has passed by and made room for that of the next high pressure.

This exposition of weather formations is in accordance with the researches and theories of the meteorologists, Bjorknes and Stüve. They provide a basis for the comprehension of all the great weather phenomena, and he who has grasped the significance of our model has had his first initiation into their secrets.

THE TWO FRONTS AND THE WARM SECTION IN AN AREA OF LOW PRESSURE

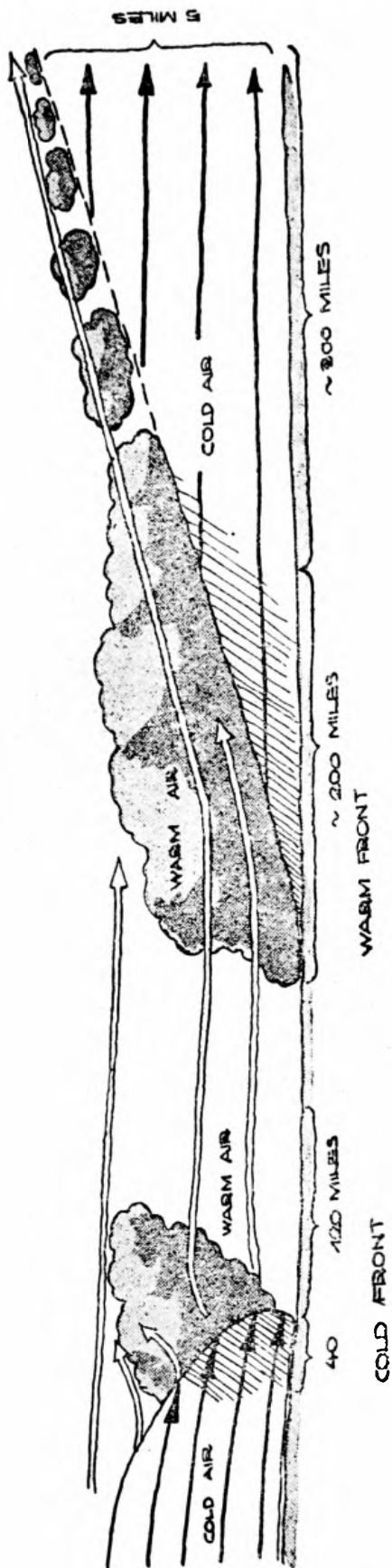

As we have seen, the front which approaches on the first edge of the sector has only a very gentle slope ; the up-current on that side is therefore weak and cannot be turned to account by the sailplanes at present in use. On the other hand the up-current energies on the invading cold fronts are extraordinarily strong, as every flyer who has ever been in a thunderstorm front knows. It ought

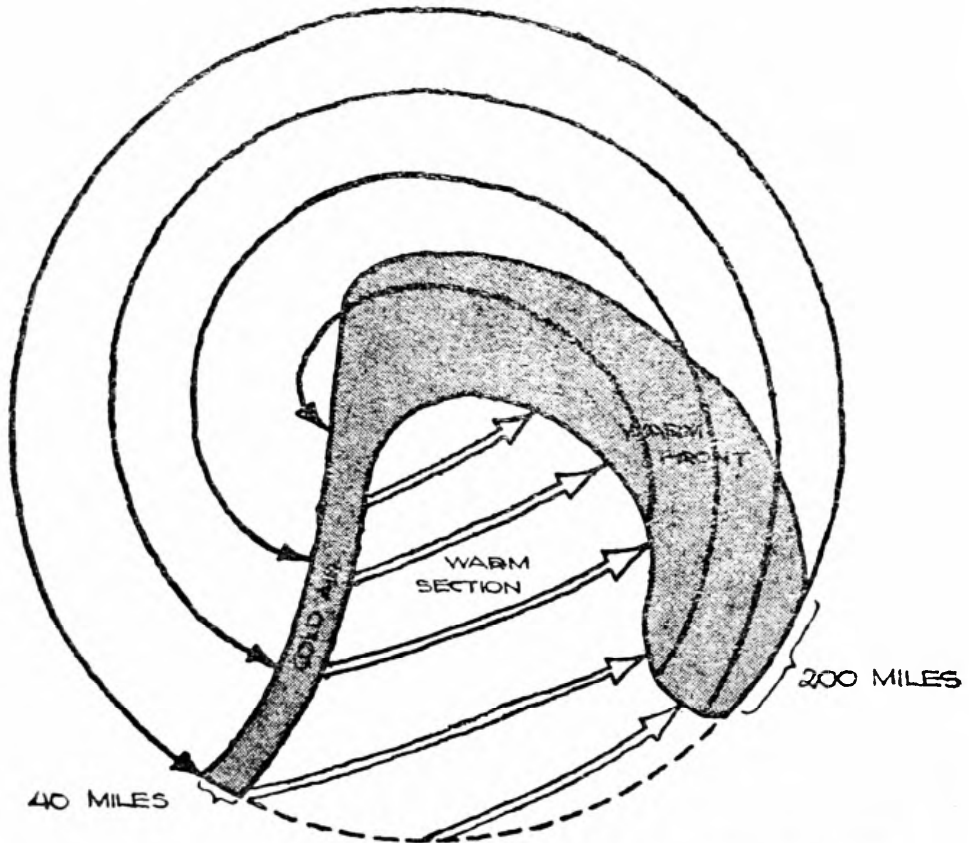

BJERKNES IDEALISED CYCLONE

to be possible to soar along such fronts for thousands of miles. If we have studied meteorology, we can observe their approach and courses according to the laws of weather formation which I have tried to describe above, or predict it from weather charts. This is of the greatest importance for the competition tactics of the soaring pilot, because he is now able to ascertain when he has opportunities for a front flight and a normal cumulus flight.

There are still many things that I could tell you about the great and wonderful region of meteorology. For instance, it is interesting for the soaring pilot to know something about the wind and the way in which it is measured, about the gustiness and squalliness, about wind staircases and periodical fluctuations. Moreover, many different phenomena may react on one another, while often different causes will produce similar effects. For example, there are in addition to front thunderstorms, heat thunderstorms of a local character, turbulence cumuli and heat cumuli. Within my limits, which are those of practical soaring, I can only speak of such phenomena when they come into direct connection with our sport. He who desires to be a successful soarer will do well to enlarge his meteorological knowledge by study and personal observation upon the lines indicated above.

Once more we recognize that one of the finest qualities of soaring flight is the stimulation that it gives us in all directions. It creates thinking pilots, who can face the most difficult weather conditions cheerfully because their fears have been overcome by knowledge.

THE FUTURE OF SOARING FLIGHT

THE answer to this question is as uncertain as are the answers to all questions concerning the future. Yet if we cannot predict in detail the exact course of the development of soaring flight, we know, nevertheless, that its future possibilities are so manifold, while its problems extend in so many directions that it will be long before we can even begin to solve them.

Soaring flight depends upon its disciples, who must provide the new material and new power. If we desire to know what we must demand from them, the question arises : what do we expect to gain by gliding and soaring ? So far as gliding is concerned the answer is simple : we want to attract as many people to this form of flying as possible.

By gliding we shall provide the strength that lies in numbers. The devotees of gliding should include the whole of a nation, and more especially its younger generation ; we ought to be able to weave a net of enthusiasm for flying sport over a whole country. We have already made such progress in this direction that innumerable groups and clubs are active in every country. That is not enough, for every small town and village should have its own training centre or its own gliding club. The expense is so slight ; a mountain or hill, with a shed on it, suffices.

The shed contains one, two, three or more pupils' machines, and perhaps funds will suffice to build a hut with simple sleeping accommodation where young folk could camp out in simple fashion. Intelligent organization would soon find ways to cater for their needs, so that soaring mountains would soon become as common as skiing mountains, perhaps even as golf links. Every young fellow would cherish ambitions to join the ranks and learn to pilot a glider.

For the attainment of this object active and continuous

propaganda is essential, but propaganda is not the only need ; machines must become cheaper, training simpler and flying easier. Machines built on standard lines would facilitate a mass production that must inevitably bring about a fall in prices, but it should also be possible to design types of machines that would cost less to build than those at present in use. The period of instruction could be shortened by the invention of gliders possessing inherent stability, while a development of the art of flight over level ground would gain recruits among the inhabitants of the plains. As a matter of fact it is even now possible to make quite good flights over flat stretches of country by using longer launching ropes. Launching can also be effected by means of catapults and motor-cars.

Thus gliding would become the first stage of practical flying by providing a host of airmen versed in the rudiments of their craft.

It is quite easy for school-teachers to make the problems of flight clear to their pupils by means of simple gliding and soaring models put together on the premises. In their playtime the children could master all the essential principles of flight. The greatest general was the man who invented tin soldiers, for he militarized the younger generation, but in the same way air traffic may one day receive its greatest stimulus from some child's experiments with a toy aeroplane.

Soaring must be carried on on a far more extensive scale than has hitherto been the case. Its task will be : to persuade as many people as possible to become good pilots.

By soaring we pick out the pilots of the finest quality. The choice is a quite simple and spontaneous one, as the unsuitable pupils are weeded out by a process of natural selection. This cannot be too strongly emphasized. The movement is still only in its infancy, and at present we do well to set much value on gliding flight, but it must not be forgotten that the real object of gliding is soaring. The more rapidly pupils pass from gliding to soaring, the more adherents will be won for flying, and the more enthusiastic will they become.

Here, too, operations on a more extensive scale will involve a reduction of expenses, because cheap machines

that can easily be flown will find the readiest sale. Veteran soarers and their friends who fly engine-driven machines will then come for week-ends to the training hill, fly for an hour or so, land and start again, and consequently we shall need many more machines capable of soaring than there are at present in existence, even if they are only gliders of the "Broomstick" type. With such it should be possible to make flights of eight hours duration—as Ferdinand Schulz did in the original "Broomstick."

Then it will be easy to arrange little competitions, distance flights and goal-flying practice. Groups of soarers could pay visits to other training schools in the same way that football teams visit each other's grounds to-day. Such matches would have a special charm for the flyer, because each fresh slope, each new district, offers its own problems and demands its own particular methods.

On long, regular mountain ranges or in coastal areas there are many localities suitable for flying clubs. If the local prevalent winds blew at right angles to the slope, it would be easy to fly from one club to another, land, convey the gliders to the hill, and fly back again—perhaps with an exchange of pilots.

The propagandist effect of soaring is greater than that of gliding, for which reason alone good soaring flying is of importance. There is hardly anyone who would not wish to do the like when he sees someone soaring silently above him. For such cases the club two-seater could be brought out, and a flight made with a passenger. One single day on which many interested passengers could be taken up in a two-seater to enjoy the experience of the start, the climb, the smooth flight and the landing at the starting place would do more to win recruits for soaring than many pages of writing.

It is a well-known fact that good soaring-pilots make good power-pilots. Their well-developed air-sense, and their flying experiences in strong winds, and in close proximity to the ground are all to the good. It is very unusual for anyone who has acquired a taste for flying through soaring not to feel an ambition to take up power-driven flying sooner or later, and this of itself opens up new paths.

The main principle of gliding and of soaring schooling is that of unaided flight. With this principle is united the idea of a natural process of instruction, which begins with gliding ; then comes soaring, and later follow the transitional exercises. Landings at a fixed goal, such as are usual in power-driven flight, can also be made by soaring. The pupil will have to practise steep turns until at last he is able to attempt correct " tail landings " in a machine specially built for that purpose. When he has progressed so far, we can with an easy conscience permit him to train in a transitional aircraft, which will be a small one-seater power-plane adapted to soaring purposes—the only difference being that the pilot would also have to control an engine. The pupil would, of course, fly solo, and when he could control this type of machine he could practise with a machine carrying a more powerful engine. Thus we see the quite natural development of flying from the first " hop " in a glider to the control of heavy power-driven aircraft. The earliest power-pilots learnt in this way—and here we have the explanation of their superlative skill, for this is the sole method by which we can learn to make ourselves one with our machine. We learn in the truest sense of the word, because we are not drilled by a system of dual controls, as is the case with the present pupils that go up in power-driven machines.

The future holds great opportunities for the expert soarers. It must not be forgotten that they are the élite of gliding and soaring flight, perhaps of any kind of flight.

Flying grounds are here the most important factor, and in this respect there is much systematic work still to be done. We must discover the suitable localities for soaring in every country. Soaring can take place over dunes and hillsides, and also even above the edges of woods, rows of houses, reservoirs and railway embankments if they are high enough. We must begin by ascertaining where there are such places and possibilities ; then maps can be made to show the best slopes for flying when the wind blows in certain directions. Descriptions of starting and landing places and other useful information would be appended.

By glancing at a map the practised soarer is already able

to discern which hillsides are suitable for long flights. It is only necessary to turn over the pages of an atlas to discover where a flight of ten or a hundred or a thousand miles could be best carried out. There are regions in the world where we already know that it would be possible to soar for many hundred miles with or without a passenger.

But now it is possible to fly independently of the land, and the future will see further progress in this direction, for our present cloud flights are the merest trial trips. Special experience will have to be gained before great achievements in cloud flying, thunderstorm flying or flights on "cold fronts" can be expected. These latter extend across whole continents at times, and travel over them for days together. It would undoubtedly be practicable to fly for thousands of miles with them if we knew the right methods and developed the right kind of machine. Then we must also develop the possibilities of soaring by means of warm currents on hot, windless days—an art as yet very little understood. So far very few really long flights have been carried out with the help of this method. Undoubtedly it will become popular just as rapidly as cloud soaring has, for long flights are easier the less wind you have and the flatter the country. Thus thermal soaring is the direct completion of auto and aeroplane towing. It is surely possible to reach with the help of auto towing heights sufficient to enable the pilot immediately to find thermal currents and then fly on for hours over the level country.

Our immediate goal (which certainly seems attainable) is to ensure that there shall no longer be any kind of weather in which we cannot fly. We must imagine the expert soarer of the future as glancing at the weather in the morning, just as a sailor does. Prior to his flight he will have made his plans in accordance with the weather forecasts; then he will fly off, make use of warm currents, drift with the clouds or tack along slopes according to circumstances. He will know how to make skilled use of thunderstorms, but probably no single flight will be carried out by means of any one of these methods alone, but by a combination of several in accordance with country, course, changes of weather, etc.

Now a word about the pilots. They, too, must improve. Soaring still demands the sensitive training, systematically thought out to the minutest detail, that is to be found in other sports. We must learn to fly better, and flight must be made easier by better resources, such as more suitable machines, and by the invention of various instruments. For example an instrument that would indicate the machine's entrance into a layer of warmer air would often help the pilot to a speedy decision. Flying intelligence must also be trained by increased meteorological knowledge.

The day cannot be far off when, as is the case in every other sport, the masters from the most distant lands will meet in friendly rivalry and exchange experiences. An Olympiad for soaring would show a splendid struggle. To-day there are signs of life and progress in our sport throughout the world, and the time must come when all nations, all pilots and all skill will be united for one great sporting demonstration.

Much depends upon technique, the progress of which is always irregular. A machine that is only very slightly better in certain respects than another, possessing, for example, a lower sinking speed or a better gliding angle, can obtain results seemingly out of all proportion to its slight superiority. While its inferior rival drops down into a gap, it will reach the next slope, from which it may often fly on a hundred miles, hundreds of miles farther, just as far, that is to say, as the length of the mountain range permits.

In the development of technique two phases may generally be observed; the first, in which enthusiastic inventors gifted with vivid imaginations venture into the realms of the impossible; this is followed by the second in which many unsuccessful experiments lead to the moment when some great man of science produces proofs of the futility of all that has been done. Often enough it has been shown that the one of these phases is just as wrong as the other.

The problem of flight by means of movable wings, which is in abeyance for the moment, is one that needs solution, and it will be the task of the soarers to bring us practical

proof as to whether anything is to be attained in that direction, but there are still other possibilities. With a propelling force of one to two h.p. the most efficient types of sailplanes can already fly horizontally, i.e. they can keep themselves hovering without any upwind. We must not even entirely deny the possibility of man one day learning to fly by his own power.

Another need of the moment is a sailplane with an auxiliary motor in the true sense of the word. Hitherto no suitable light motor has been found. In that direction lie new possibilities for soaring over level stretches of country, achieving contact with clouds and the bridging over of gaps.

There are also other resources which we can call to our aid. The fast motor-car can and must be further developed as a launching agent, while a slow sailplane can also be sent up as a kite at the end of a rope and then set free for further independent flight.

In the chapter on "Auto and Aeroplane Towing" we have seen that auto-towed flight has been the means of bringing soaring flight to the flat country. It has simplified the organization of the soaring school to such an extent, that auto-towed flight will be possible in training quarters situated in the close neighbourhood of cities and towns, where the business-man will be able to glide and soar during the short leisure periods at his disposal. It is probable that the beginner's entire training, sooner or later, will be carried through by this method.

Both free and captive balloons can likewise lift soaring planes, and it has been found feasible to tow them aloft by means of aeroplanes. In future aeroplane towing will gain more and more ground. To-day we are already at a point where, even if we cannot soar, by means of a few minutes of expensive towed flight we are able to do many minutes of cheap gliding flight. Conditions are even more advantageous when we think of soaring. Then the aeroplane in cloudy or cumulus weather can take a squadron of sailplanes up in an hour, and leave them under a cloud where they then can fly on for hours. As we have shown before, it will be possible in future to execute the whole of

the soarer's training up to the highest performances in the level country, and this by using automobile towing and later upon taking the more advanced pupils and experienced pilots into the up-current areas of the clouds. In the future of soaring flight, aeroplane towing will hold an important position. This is the next direction in which experiments will be made for the method has a value that is not merely a sporting one. It should prove possible to harness a heavy machine, consisting mainly of engine and tanks, to a glider capable of carrying a number of passengers, the advantage of such an arrangement being that the motor-power, with its attendant danger of fire, is completely separated from the passengers' compartments. Such a glider could land on its skid—a great advantage in cases of forced landings. If several gliders were thus attached one behind the other, it would be possible to detach them and their passengers successively at localities along the prescribed route. In this way mail could also be conveyed safely to its destination.

Experiments of this kind have already been successfully made from airships, and perhaps in the future every air ship will carry its life-glidings, just as now every ocean liner carries its lifeboats. Should a "flying-train," such as I have described above, be carrying valuable consignments, as, for example, gold from a bank, to a place lying on the flying route, it would always be advisable to send the consignment down in a glider steered by a good pilot rather than to trust it to a parachute which is liable to be carried in a wrong direction by unexpected wind currents.

Sailplanes might also make advantageous use of the newest form of propulsion, the rocket. This is really the ideal auxiliary motor force, its great advantage being that it weighs nothing after it has been used, as the empty casing can probably be detached. For starting purposes a powerful propulsive rocket could take the place of the present starting crew.

It may even not be necessary to make use of such powerful means. In order to move forward, a sailing boat on the water makes use of the difference in velocity between two

mediums—air and water ; in the air itself there are similar differences. The mast of the sailing boat also rises from one layer of air into another ; if we wish to apply this method in the atmosphere, we must accommodate ourselves to atmospheric conditions. As a rule the air close to the ground travels at a considerably slower rate than the higher layers, while sometimes it happens that completely different directions are taken by a current of air a hundred feet or so above a lower one. In that case, we have two mediums moving in opposite directions, but it would naturally be nonsensical for a soarer to contemplate utilizing this difference by any means similar to the mast of a ship. He has to find some new way of obtaining contact with the upper layer, and a Bavarian inventor, Herr Wolfmüller, advises the employment of a kite for such purposes. If there was no wind or only a very slight and slowly moving breeze it would be possible to have a sailplane drawn along the ground by means of a kite which had risen into a layer where the air was moving more rapidly. Audacious as his idea may seem, Herr Wolfmüller has proved its feasibility. Owing to lack of means he could not experiment with a glider, but he sent up two kites, connected by a rope ; on every occasion they flew so far in this fashion that they disappeared ultimately from the sight of the watchers. In this direction there is opportunity for work which may prove profitable for soarers.

There is one great and much disputed problem which I have intentionally left untouched till the last. This is the question of dynamic soaring. In the earliest days of soaring flight many people maintained that only such soaring could lead to any practical results, but later, when soaring as it is now generally practised, i.e. static soaring, obtained such good results, the problem was almost lost sight of. Now it is emerging again, and the task before us is that of learning to fly without up-currents by utilizing the gusts of the air or the different velocities of movements in apparently horizontal air currents. The earliest inquirers into the problems of air velocities discovered that the wind never blows quite regularly. Every pilot, whether soarer or power-pilot, knows that it is possible to utilize

isolated gusts for the gaining of height, but we do not yet know the best methods of doing this.

Again and again we are stimulated to further inquiries in this direction by our observation of soaring birds, such as the albatross. On the occasion of a recent journey round the world, Professor Prandtl, the director of the Aerodynamic Research Institute of Göttingen, studied the flight of these birds, which are the best soarers of the feathered world. While many observers believe that ocean birds only fly in the up-currents produced by the crests of the waves, Prandtl has another explanation of their long and wide journeys over the billows. On the voyage from Yokohama to Honolulu he was able to gain a clear idea of their method of flight.

They utilize the difference between the wind velocity immediately above the surface of the water over which they have chosen to fly and that higher up. They rise against the wind by means of the energy which is freed when they climb suddenly from a slowly moving layer into a more rapid one. Having risen, they turn and fly down again with the increased speed they have gained; in the lower layer they repeat the manœuvre. The amount of energy which can be acquired in this way can be calculated mathematically; hence it follows that we ought to be able to hover above the sea for as long and as far as we desire, provided that there is a wind of sorts. This axiom is applicable everywhere where different atmospheric velocities are to be encountered.

It has also been shown theoretically and by experiments in wind tunnels that climbing is feasible in variable winds which blow in gusts from different directions on our level or from above or below us.

All these problems—most particularly that of the general nature of wind gusts—have not been sufficiently exploited, and we cannot say what future investigations of their nature will be possible. It is futile to deny the possibility of solving any technical problem, for which reason it should be possible to imitate the flight of the albatross with a small machine that could easily be manœuvred. There is a crying need for “wind feelers,”—instruments that

would indicate beforehand the rising and falling of wind.

It is hardly necessary to discuss more fully the numerous (but often quite useless) experiments which have been carried out in all directions in connection with soaring flight, as I have already pointed out some useful fields of inquiry. Soaring is a sufficient miracle in itself, while the progress from Lilienthal's first leaps to our present cloud soaring has surely not been more difficult than it will prove from the latter to long flights across the ocean. The programme of immediate work indicated in this chapter is one worthy of occupying our finest brains and sternest energies for years to come. This book is not intended to be a statement of grey theory ; I should prefer it to be a stimulation, a finger-post pointing the way to practical progress. Therefore, let us get to work ! Let us betake ourselves to the flying fields, the workshops and the observatories !

The future of soaring is still uncertain. Every take-off is a matter of uncertainty for the pilot, even though it be the beginning of a record flight. Gay optimism, faith in human ability and a cheerful willingness to take the rough with the smooth are the elements which compose the flying spirit, as I know it in the best sense of the word. I have no fears for the future of soaring, and I earnestly desire that this little book might be a helpful stone in the structure of its proud edifice.

Soaring belongs to youth, and to both belongs the future !

THE PROGRESS OF SAILPLANING THROUGH- OUT THE WORLD

DURING the last ten years remarkable evidence of the rapid progress of sailplaning has been provided by the results attained through the annual competitions in the Rhön. The development of this new kind of sport, both as regards the scientific and practical value of the achievements has been undoubtedly brought about mainly in Germany. Moreover, the importance of soaring and of its scientific results has secured recognition throughout the world to an ever increasing extent. New ground has been gained with striking rapidity. Records were set up and broken, the whole world taking an active share in the movement.

Even prior to 1930, reports were received from distant and secluded districts of Russia of a sailplaning competition, the importance of which was hardly inferior to that of similar meetings in Germany. Gliding and soaring had made great strides in that country. The development programme comprised the formation of sixty new gliding schools.

In the autumn of 1929 another competition took place in the hilly regions of the Crimea, where the soaring experts Hesselbach, Schulz and Nehring had previously set up their records. The competitors had to undergo nine tests, the Russian conditions requiring flights of twenty-five minutes' duration. Wenzlaw in his high efficiency sailplane, which had a wing span of fifty-two feet reached a predetermined point of twenty-one and two-third miles (34.8 km.) away and brought his machine back to the start. With a flight of ten hours twenty-two minutes the winner of the duration flight competition, Stepan Tschonok, was also able to beat the times achieved in the Rhön. The great heights attained were perhaps the most interesting feature. Both Koschitz and Jumaschef rose to

a height of four thousand six hundred and forty feet (one thousand five hundred and twenty metres) above starting level. These results, which were achieved under a cloudless sky were undoubtedly possible only by the exploitation of thermal currents set up by the exceptionally powerful rays of the sun prevailing in the Crimea immediately after a shower of rain. In attaining this height Koschitz also managed to cover a distance of over twenty-one and a half miles (34.6 km.).

The large number of five hundred and eighty-eight flights made in the course of the competition and amounting to a total duration of one hundred hours provided proof of the progressive energy of the Russian sailplaning movement.

In the spring of 1930 gliding was taken up with renewed vigour in England. During the previous winter on the invitation of the Royal Aeronautical Society, Professor Georgii lectured before that Society and explained to the experts the practical gliding results hitherto attained as well as the intrinsic value of the new sport. However, the majority of the sporting community was anxious to see a practical demonstration of the possibilities of the glider. In the latter half of May, therefore, I went to England, taking with me the "Wien" in order to demonstrate the methods of soaring and to advise interested groups and clubs on practical gliding instruction.

Demonstrating and lecturing from the time I arrived until the middle of July, when I returned to Germany in order to participate in the Rhön competition, I passed the most successful time of my activities in an atmosphere of sincerest friendship and sporting camaraderie. In a period of six weeks, with the assistance of the British Gliding Association—whose chairman Mr. Gordon England took a large share in the responsibility for the success of my demonstrations, as did the President of the Royal Aeronautical Society, Colonel the Master of Sempill—I was able to carry out seven meetings and in co-operation with the young German gliding expert Karl Magersuppe, who had been brought over to England by the *Daily Express*, managed to rouse the enthusiasm of thousands of spectators

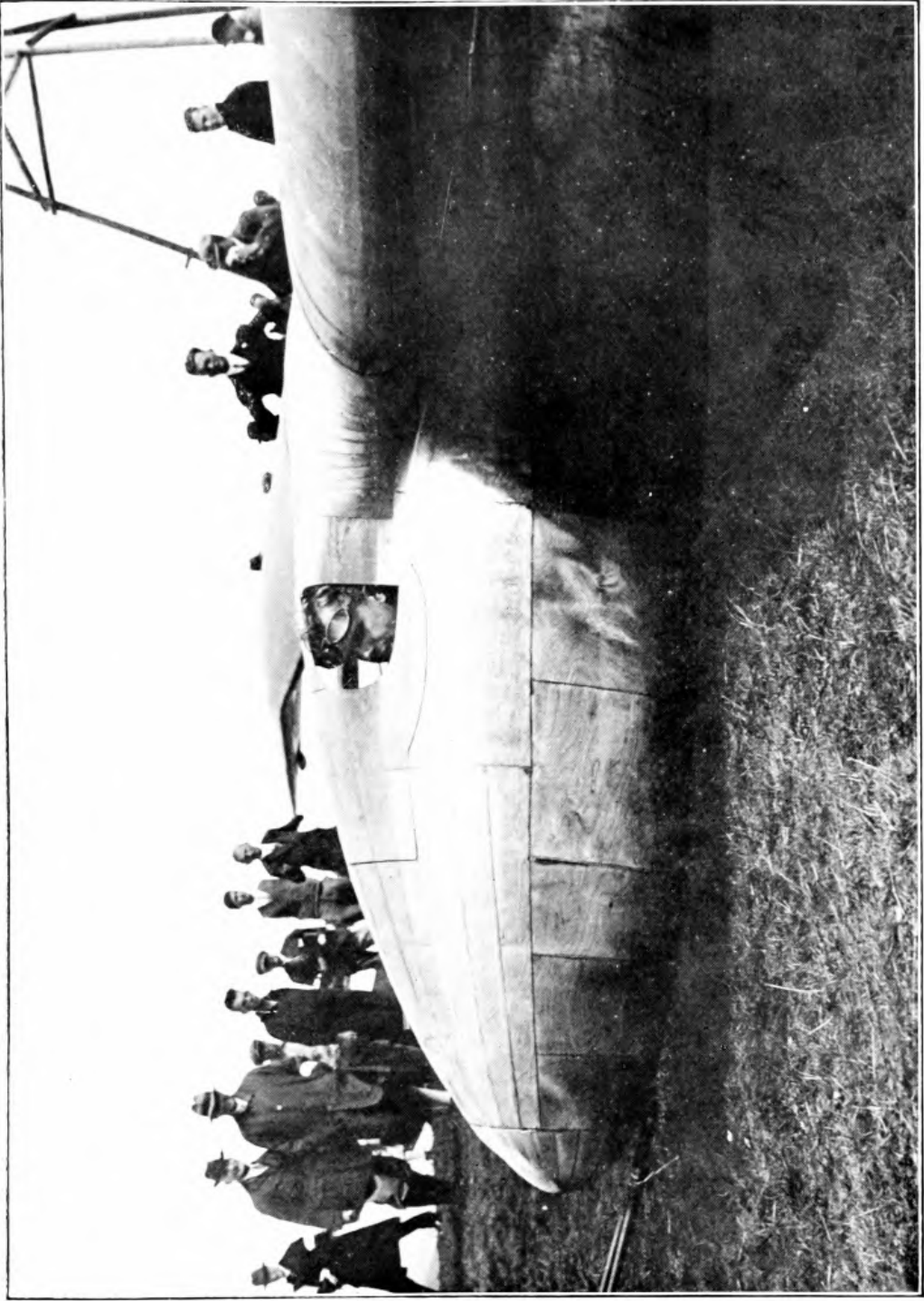

83. THE "FAENIR" FLOWN BY GÜNTER GROENHOFF

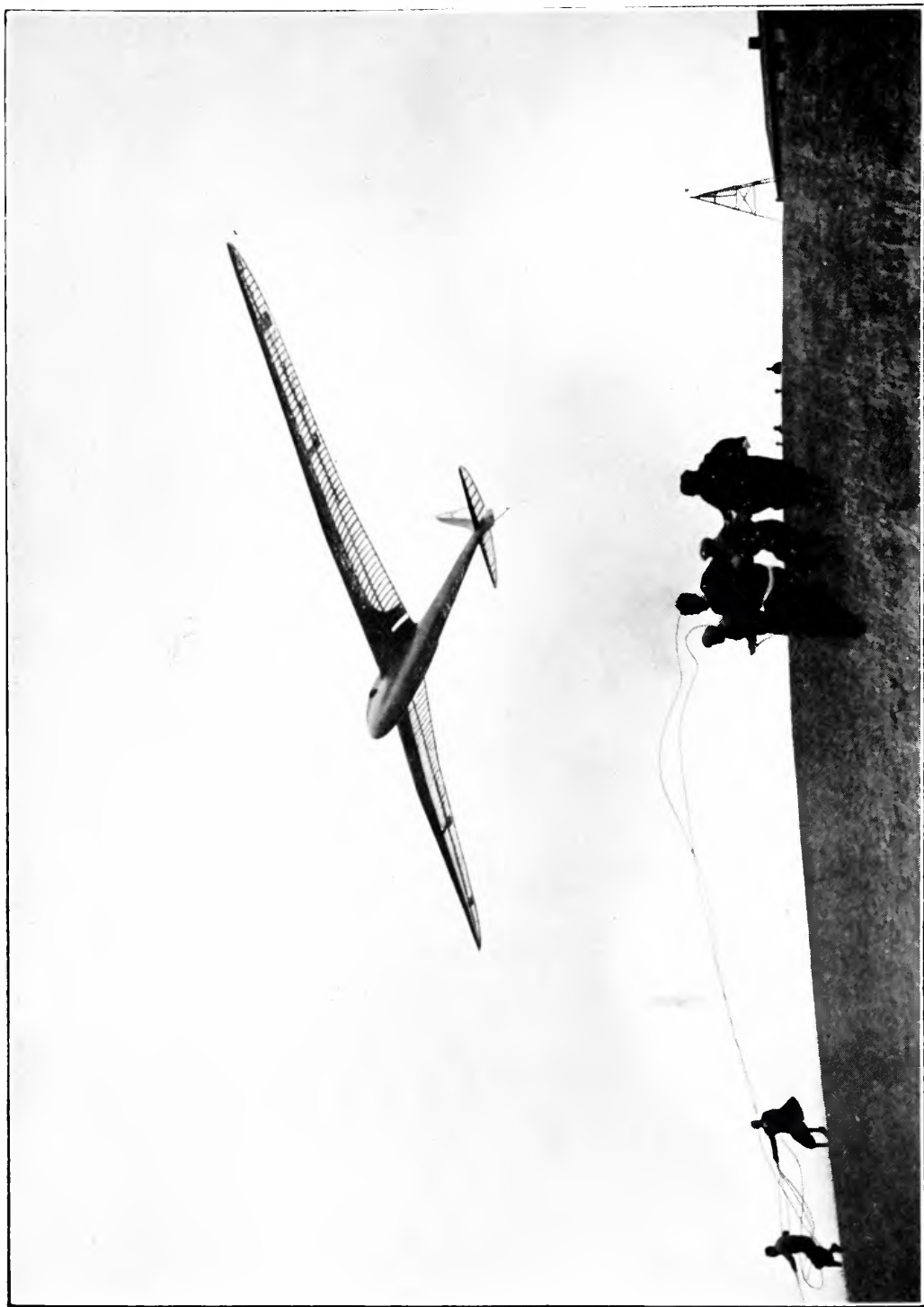

84. THE "FAFNIR" TAKING OFF. THIS IS THE MACHINE IN WHICH GÜNTER GROENHOFF MADE A NUMBER OF SPECTACULAR FLIGHTS AND RECORDS.

Facing page 319

as well as many of the foremost air experts of Great Britain.

The short time at our disposal was crowded with giving demonstrations, explanations and reports. The interest taken in the lectures I gave in Maidstone, Portsmouth, Folkestone, and London was merely a small indication of the enthusiasm with which the British sporting community embraced this new sport.

On Whitsunday in the course of a three hours' flight from Itford Hill I twice succeeded in picking up a strong rising current under alto-cumulus clouds, which carried me to a height of two thousand three hundred feet above starting level.

On the 15th June I reached Portsmouth from Itford Hill, following the Downs as far as Petersfield and coming down on Portsdown Hill late in the evening. This was the first successful major long-distance flight in England. Whilst I was engaged in inspecting the country near Weymouth for a further demonstration Karl Magersuppe carried out a flight of three hours ten minutes duration on the 21st June.

Only by exploiting very carefully indeed, every small up-current from the slopes of the hills did I manage to bridge the gaps in the range of the South Downs. The effort raised general enthusiasm in England since the success apparently provided the proof that the English countryside actually permitted carrying out of long-distance glides.

Since then strong ties of mutual friendship have bound me to the British air sport community. I regard as one of my greatest privileges the fact that I was given the opportunity of demonstrating to His Royal Highness the Prince of Wales the art of soaring flight. Shortly afterwards, at the beginning of July, I had to return to Germany for the Rhön Competitions. With a heavy heart I took leave of England, and my sailplane "Wien" accompanied me across the Channel, as yet unaware of the fact that the next time we should both take a view of these waters would be from the air.

In order to raise the standard of the efficiency of both the pilots and the machines, minimum standards set for the 11th

Annual Rhön competitions were generally increased. Although this fact alone provided an incentive to the pilots, the considerable improvement in the results, more particularly in the practice flight competition was mainly due to the close rivalry existing between a number of pilots of more or less equal skill and ability.

The utmost energy was expended in the Rhön on duration flights. Even in the preceding year there had been only two flights exceeding five hours in duration. In 1931 there were as many as twelve such flights, seven of which were extended to upwards of seven hours. Van Husen of the "Akademische Fliegergruppe" of Göttingen returned the longest time with eight hours thirty-eight minutes. He was closely followed by Mayer of the "Luftfahrtvereinigung," Aix-la-Chapelle, who remained in the air for eight hours twenty-eight minutes. Both these pilots had really entered for the performance competition but the sporting inducement offered by the close rivalry to secure the duration prize for practice pilots was too much for them. How closely this prize was contested will be gathered from the fact that Starck of the "Akademische Fliegergruppe," Darmstadt, made three flights of five hours duration each, in order to win a special prize.

During these duration flights cloud soaring was generally practised. This will be made apparent by a study of the considerably greater heights attained. Bedau reached a height of five thousand three hundred and eighty feet (one thousand six hundred and forty metres) above the starting point in the "Luftikus." Bedau, who had been in the air for over three hours, was caught in a particularly strong up-current inside a cloud, apparently strengthened by the rising current from the hillside. His machine was carried up at a speed of sixteen and a half feet per second. Inside the cloud Bedau evidently lost his sense of equilibrium, for presently he was seen to emerge from the cloud in a steep downward spiral, the barograph recording a velocity of descent of eighty-two feet per second. Bedau flattened out and resumed his glide in the ordinary manner, completing a flight of seven hours thirty-four seconds' duration.

This performance of Bedau's will convey an idea of what was required even of the practice pilots, as will also the total flying hours : Starck, twenty-seven and a half hours ; Bedau, twenty-four and a half hours ; Pätz, sixteen and a half hours.

An innovation for the practice competition was the stipulation that the pilots were to fly to any point at least three miles (five kilometres) distant from the Wasserkuppe and then to fly back to the starting point without any intermediate landings.

The original idea of this prize was for the pilots to work their way along the hillsides. But matters turned out as they had done before when I made my Himmeldankburg flight in 1928. The competitors of the practice class secured the prize by cloud soaring. On the 17th the "Darmstadt" piloted by Starck had been in the air for several hours when he rose to a height of two thousand four hundred and ninety feet (seven hundred and sixty metres) by means of the rising current under a cloud. Heading against the wind under a cloud bank Starck took his glider a distance of three and a half miles (five thousand four hundred and fifty metres) and then returned to the Wasserkuppe with the tail wind. Bedau closely followed the "Darmstadt" but at the lower altitude of one thousand one hundred and eighty feet (three hundred and sixty metres). For this reason Bedau made for home somewhat sooner, after having covered a distance of three and a quarter miles (five thousand one hundred and fifty metres). The fact that such flights seldom fail where there is a suitable rising current under clouds was well illustrated by Pätz, who on the "Rheinland" was also able to fulfil the conditions of a return flight in the course of the same afternoon. In certain circumstances and over shorter distances, it is undoubtedly easier to exploit the possibilities of cloud soaring than to struggle along by using the up-currents from each hillside. From this point of view Huch's flight though unfortunately not quite successful, was very satisfactory indeed. Huch managed to forge his way along the hillsides as far as the Milseburg, covering at least a distance of three miles (five kilometres). In

returning, however, he lost too much height to permit of a landing on the Wasserkuppe itself.

This year the pilots participating in the performance competition were set a difficult task. The weather conditions were not nearly as favourable as in the preceding year. Rising currents under clouds were active only for a few hours at a time and did not suffice for long flights. Moreover, the long squall fronts were not plainly marked. The achievement of long distance was only gained by fighting every inch of the way. Under these conditions the younger pilots naturally found it hard to follow my example and cover the necessary ground for reaching the mountains of the Thüringer Wald or the hilly regions beyond. Whereas I repeated my last year's performance of twice exceeding the ninety-three miles (one hundred and fifty kilometres) limit, the next best performances of the younger generation represented by Mayer, Hurttig, Groenhoff and others were restricted to about one-third of the actual distance covered by myself.

Attempts have been made to give all kinds of explanations for this difference in the results. In some quarters it has been stated that my machine was very much better, in others, that I had a "pathological flair" for soaring. I am myself well aware of the fact that both opinions are far removed from the truth. Admittedly, my "Wien" is a high efficiency machine and has the advantage of behaving splendidly in rough weather as well as in a gentle breeze. Nevertheless, in every contest for which I entered this glider, there were several other machines of nearly equal performance, in some respects, in fact, even superior. The success of my efforts is not due to any particular flair but simply to systematic work in laying out my plans in conjunction with using my common sense when in the air. This was proved, for instance, when I flew along the course taken by Nehring in his "Darmstadt" in 1927, and under similar conditions I covered thirty-two miles (51.5 kilometres), coming down at exactly the same spot where at the time Nehring had effected his landing.

On August 13th several line squalls passed over the

Wasserkuppe, the first one reaching the top of the hill shortly after 2 p.m. The squall was not very clearly defined and the up-current was weak. Nevertheless, I managed to climb to nine hundred and eighty-five feet (three hundred metres), at which height I attempted to get away. From the Wasserkuppe I reached the High Rhön, where I lost height to such an extent that I fell to six hundred and fifty-six feet (two hundred metres) below the summit of the Wasserkuppe before dropping into the valley dividing the Rhön from the Thüringer Wald. Repeated showers made matters worse as they restricted visibility and added considerably to the weight of the machine. More particularly, the aerodynamical qualities of the glider were impaired by drops of rain clinging to the leading edge of the wing. At a very low altitude I finally succeeded in crossing the critical valley and I managed to regain height on reaching the hills of the Thüringer Wald. At times, heavy rainfalls reduced the view to such an extent that it became impossible to distinguish the individual ranges for which I was heading. Seeing that the rain rendered flying too difficult I made up my mind to run ahead of the storm and to proceed from hilltop to hilltop along the Thüringer Wald, taking the route I already knew. The squall, accompanied at intervals by thunder and lightning, followed about half-an-hour behind. Forging ahead from one hill to the next I reached the basin between Thüringer Wald and the Fichtel Gebirge. Being too low to attempt this hop I waited for the following squall to approach which I saw coming up close behind. Three times I endeavoured to head into the squall standing at right angles to the side of the hill. The final attempt was successful and I was carried to a height of two thousand three hundred feet (seven hundred metres) thus attaining the greatest altitude of the flight after having been in the air for three hours. Whilst trying to make the most of the squall I was enveloped several times by the clouds. With my view thus obstructed I followed the path of the storm so as to avoid running into the hills of the Fichtel. I finally landed in the rain, fog and partial darkness three miles (five kilometres) as the crow flies, from the Czech

frontier, near Rehau, after covering a distance of ninety-five miles (150.3 kilometres).

The second line squall which passed over the Wasserkuppe that day came up one and a half hours after I had taken off. It was stated by the experts that this squall showed a distinct rolling formation of the leading cloud besides being exceptionally strong. Unfortunately, the storm travelled so quickly that the gliders could not be got ready for launching in time. A further one and a half hours elapsed when a third rain storm appeared in the west. Hurttig managed to get his machine out early enough. A difficulty, however, arose inasmuch as the clouds hung very low, leaving the mountain tops enveloped in fog after their passage. Hurttig, who had gathered detailed information on the tactics of storm flights as described by me during the previous year, had his machine launched at the right moment, headed for the front of the line squall and was carried over the High Rhön after having attained a height of one thousand and fifty feet (three hundred and twenty metres). On the lee side of the mountains he was caught in the strong downward currents but he soon picked up the front of the squall, which again lifted him to a height of one thousand two hundred and ten feet (four hundred metres) above the start. The rest of the flight as described by Hurttig himself and in accordance with the record of his barograph was very similar to my own flight of the previous year. Hurttig kept his machine at the proper altitude and at the correct distance from the front of the squall. Unfortunately, this continued only for a period of fifteen minutes, during which time the formation of the ground did not interfere and material variations in height were not recorded. Hurttig then got into the clouds, but he was lucky enough to come out again right over another valley, the crests of the mountains on either side already being capped by the fog. In this manner Hurttig managed to cover a distance of over twenty-five miles (40.6 kilometres). This effort proved that even the younger pilots can successfully carry out storm and line squall flights, provided they systematically and carefully make a study of the previous experience gained by others.

Hurttig made two further distance flights exceeding twenty-five miles (forty kilometres), in the case of which he followed Nehring's well-known route along the hillsides.

The most interesting prize offered in this competition was the route prize. To secure this trophy the competitors were required to make a return flight to the nine and a half miles distant Kreuzberg (fifteen kilometres). This route could not be negotiated simply by following the crest of the hill. Hops had to be made across two valleys and a mountain ridge intervened running practically parallel to the wind. This latter obstacle could be overcome only by squeezing through a kind of pass. In view of the awkward relative position of the ridge to the wind exceptionally strong eddying currents prevailed in this narrow passage, setting up strong intermittent up and down currents, involving a certain risk to the pilot attempting the flight. Two machines were successful in this special venture but they managed in quite different ways. On the day before I set out for my long distance flight which took me to Rehau, a line squall approached the Wasserkuppe which, however, was rather remarkable for failing to show any appreciable rising currents. Since the general trend of the weather, in accordance with the forecast that morning, was expected to be favourable several pilots were on the qui-vive. Groenhoff on the "Fafnir" was the first to be launched, closely followed by Mayer, "Aachen," myself, and Kegel bringing up the rear with his "Kassel." We all had the intention of carrying out a rainstorm flight. Mayer covered a distance of twelve and a half miles (twenty kilometres); Kegel reached Tann, a distance of nine and a half miles (fifteen kilometres), whilst Groenhoff returned to the Wasserkuppe where he came down as the front of the line squall failed to provide any lift. I, for my part, followed the front of the squall towards the Milseburg, but changed my programme at once on noticing the lack of the required rising currents. After allowing the front of the squall to pass over me I made my way back to the Wasserkuppe, flying partly in the clouds and partly with ground visibility greatly restricted. I carried on past the

Wasserkuppe in order to make an attempt on the Kreuzberg. Difficulties were not experienced in effecting the hop across the Gersfeld valley. Arriving at the previously mentioned pass at the ridge a long struggle began, to reach the necessary height for getting across. Several times the machine was caught in downward eddies causing it to drop suddenly one hundred to one hundred and thirty feet (thirty to forty metres). After patiently waiting for the right moment I slipped across at low altitude reaching the Kreuzberg and returning to the pass, where I again had to wait for a considerable time before I was able to fly back again to the Wasserkuppe.

Five days later the flight was repeated by Groenhoff. Owing to the strength of the up-currents under the clouds a considerably greater height was reached by him than I had been able to attain. Whilst the greatest height I had gained in the course of my flight was about six hundred and fifty-six feet (two hundred metres) Groenhoff, on his way out, went up to about two thousand six hundred and twenty feet (eight hundred metres), which sufficed for him to reach the Kreuzberg from the Wasserkuppe and to turn in one unbroken glide. The exceptionally high aspect ratio and the great speed of his "Fafnir" may have assisted him in reaching the goal, but on the way back these properties of his machine were of lesser advantage. On reaching the area of eddying down-currents which had given me all the trouble, Groenhoff exhibited all his grit and flying skill in a prolonged struggle to get over the top. After several attempts he eventually succeeded in passing the obstacle and, working his way up to make good a loss in height of six hundred and fifty-six feet (two hundred metres) below starting level, he landed on the Wasserkuppe after five hours, much to the surprise of his comrades. This effort is a fine example of what can be achieved even in unfavourable circumstances by good judgment, persistence and skill.

In view of the ability shown by Groenhoff, Hurttig and Mayer in the course of these events, expectation rose to a high pitch when favourable flying conditions were forecast towards the end of the competitions. On the last day,

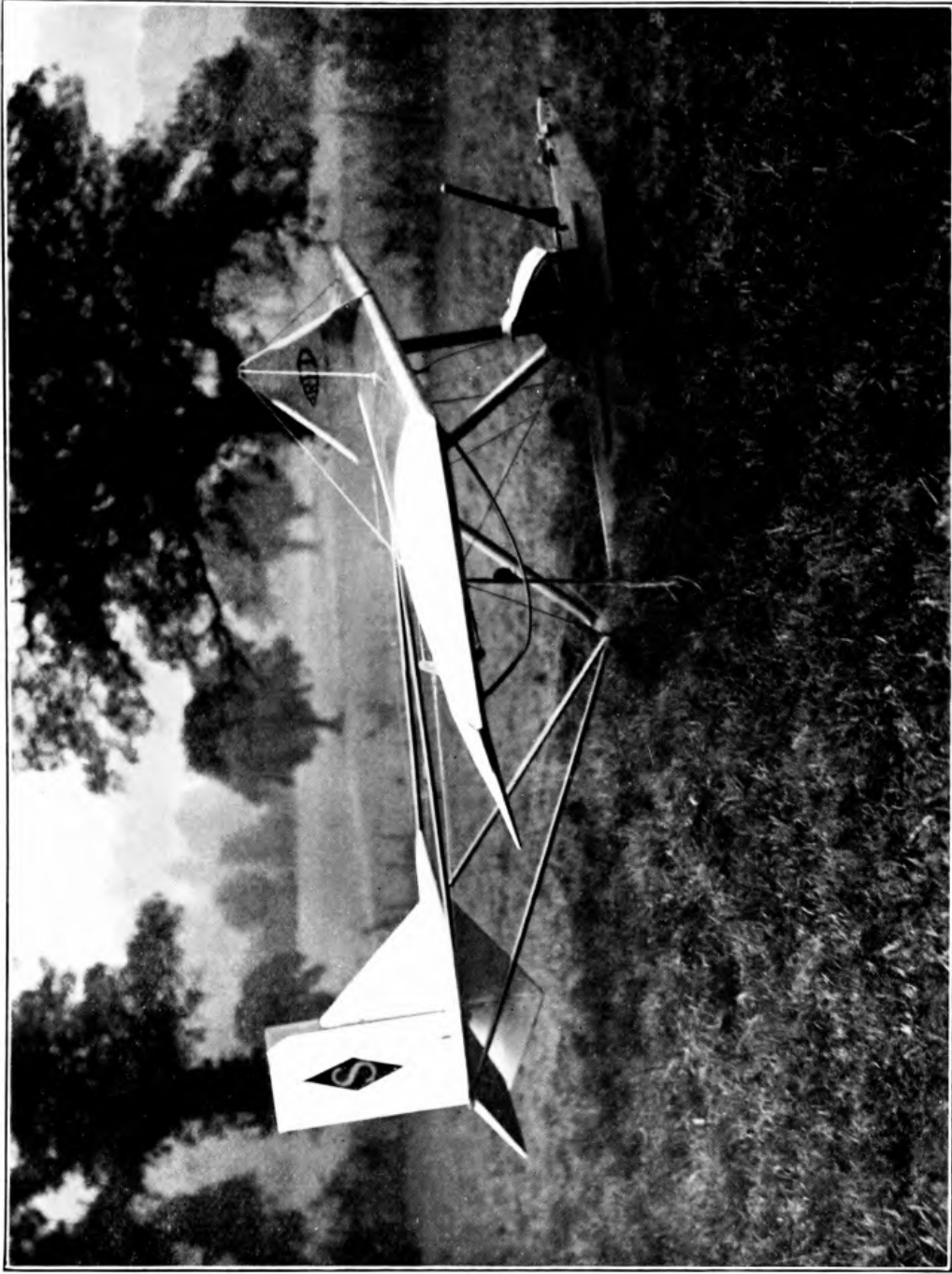

85. THE R.F.D. DAGLING. A PRIMARY TRAINING GLIDER BUILT BY
R. F. DAGNALL OF GUILDFORD
By courtesy of "Flight"

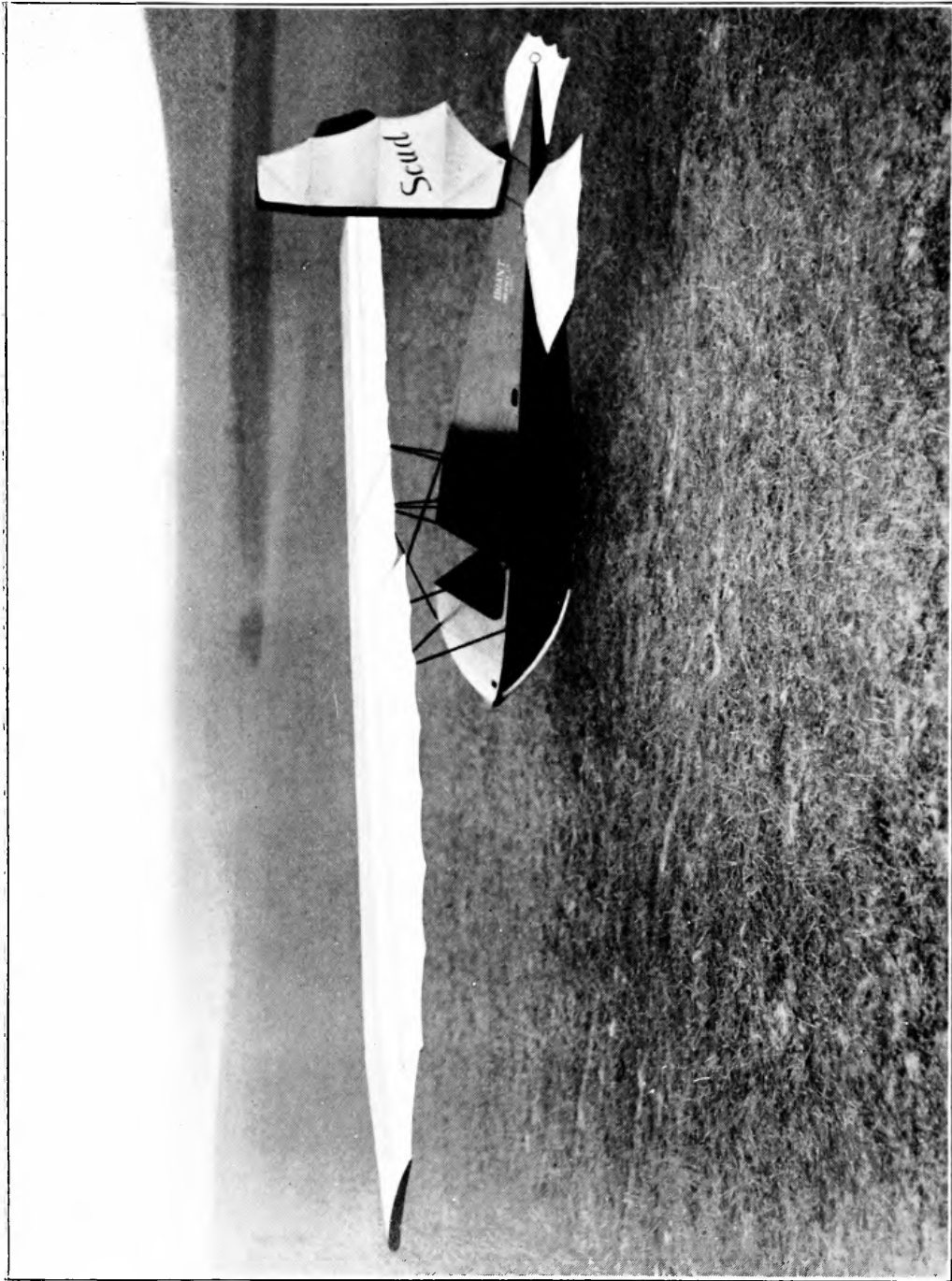

86. THE "SCUD." A BRITISH INTERMEDIATE SOARING GLIDER. BUILT BY
E. A. ABBOTT, LTD., FARNHAM, AND DESIGNED BY MR. L. E. BAYNES.

By courtesy of "Flight"

August 24th, cumulus formations again appeared in the sky. Seeing that I had explained several times the route to the Thüringer Wald as well as the tactics to be adopted, this last day was expected to bring very close contests. A large number of the machines had been launched fairly early. At times there were as many as fourteen machines in the air, mostly awaiting a favourable opportunity to head away on a distance flight. I did not go up myself until after lunch, heading away from home after having reached barely six hundred and fifty-six feet (two hundred metres).

At this time Groenhoff's machine was still at a fair height straight above me. When he saw me starting away he stopped soaring around the Wasserkuppe and followed in the direction of the Thüringer Wald. His machine being the faster he quickly caught up and forged on ahead. I saw him again just before crossing over the most difficult point of the route, but he had lost so much height that he was forced to give up after covering a little over sixteen miles (twenty-six kilometres). The others who had followed at the same time in similar conditions were just as unlucky as Groenhoff. Hurttig had started a distance flight and managed twenty-four and a half miles (39.3 kilometres): Mayer reached a distance of nearly twenty-eight and a half miles (forty-six kilometres) and would have recorded the best performance of the day had I not continued to go farther ahead. I followed the route I already knew with the intention of reaching the Fichtel mountains and of crossing them, which in spite of several attempts I had hitherto been unable to do. Late in the evening I arrived at the foothills of this isolated range. The wind was exceedingly weak and I was hardly able to keep in the air. A cloud bank, coming up in the direction of the wind, finally brought a very weak rising current, at the same time, however, enveloping the tops of the mountains in fog. Very slowly I gained height, riskily flitting through the ragged and low-hanging clouds which glowed with a dark red colour in the rays of the setting sun. The lights from the shelter huts on the highest point of the Fichtel threw a faint glimmer through the misty air as I crossed the

Fichtel for the first time, passing close under the summit of the highest of its mountains. Shortly before landing near Markt Redwitz I had a short race with a motor car with its headlights glaring into the night and finally a duel with an overhead high tension cable which I failed to see until the last moment, and then this flight covering a distance of ninety-one miles two furlongs, came to an end, again deciding the competition in my favour.

The 1930 competition in the Rhön produced particularly good performances on the part of the practice pilots. It must be regarded as a further achievement that this year's performance tests proved the possibility of carrying out long distance flights even in comparatively unfavourable weather conditions. After all, it is one of the aims of the movement to enable as many pilots as possible to put up good performances in all kinds of weather conditions.

The Rhön competitions also afforded manifest evidence of the friendship which had sprung up between the British and German gliding communities. British air and sail-planing experts paid us a visit on the Wasserkuppe, giving us the opportunity to renew the former acquaintance with our friends. Unfortunately a British machine had not been entered for the contests. Nevertheless, captains and members of various British gliding clubs, accompanied by Mr. Gordon England, the Chairman of the British Gliding Association, and the Master of Sempill arrived on the spot and were received with great enthusiasm. For a few days they all shared our "Red Indian" camp life in the "Wild Rhön." Sir Sefton Brancker in a Puss Moth appeared on the scenes of the "Rhön-Olympiad," and those who in England had not had the opportunity of admiring and appreciating this remarkable personality were now in a position to do so. Our British visitors offered the "English Visitors' Prize" consisting of a one week's trip to England, and I was lucky enough to win this prize by the flight I carried out on the last day of the contest, thus enabling me to pay a further visit to England, where the British gliding community again received me with the most cordial hospitality.

Apart from what was being achieved in the Rhön, the

gliding experts of other countries came more and more into the picture.

A spirit of adventure coupled with sporting dare-devilry, two well-known traits in Wolf Hirth's character, may have induced him to set forth on his journey across the Atlantic, taking with him to America his sailplane the "Musterle," and accompanied by Fritz Ackermann, a native of Kassel, and the constructor of my own glider, the "Wien." Hirth had previously tried to fly to America in a light aeroplane via Iceland and Greenland. On reaching Iceland, owing to political difficulties, he had been forced to give up his attempt.

He made his first American glide on September 21st, during a competition in Elmira, N.Y. Unfavourable weather conditions prevailed during the first few days, only Hirth and the American, Jack O'Meara, being able to stay in the air for more than an hour at a time. The wind freshened up, however, during the second week of the contest, and better performances were the result.

The machines entered by America, some of which had been designed by German experts, proved their worth alongside the two German planes, the "Schloss Mainberg" of Haller and Hirth's "Musterle." The utility gliders entered by Professor Franklin were particularly worthy of note.

Franklin (Ypsilanti, Mich.) was successful in winning the point-to-point trial, putting down his machine with great accuracy on the finishing line. He also carried out several flights of over one hour's duration. Moreover, the Franklin machine secured another of the big prizes, winning the duration prize when piloted by Hastings (Los Angeles) with a flight of seven hours forty-three minutes. This was the longest of the many duration flights at which Hastings excelled during the competition. Nearly equally successful in this department was Eaton (Norwich N.Y.) in a Baker-McMillen machine, who, shortly before the end of the contest, remained in the air for seven hours twenty-three minutes. He had already exceeded five hours once before. Jack O'Meara, of Akron, Ohio, in a machine of a similar type to Eaton's, carried out two flights of six hours and two and a half hours respectively, besides a

great many others exceeding thirty minutes. Apart from this he succeeded in a splendid long distance attempt, covering ten miles ; on another occasion he reached a height of two thousand three hundred and four feet.

One of the competitors was a young sportsman of Pittsburgh, Gus Haller, who had been in Europe in order to gather experience in soaring. Haller had practised in the Rhön and there obtained his " C " certificate. When he heard that I had gone to England to help the British Gliding Association and to give a fillip to the movement in England, he packed his bags and followed across the Channel at once. From that time he faithfully accompanied me on my tours. He was not only of the most valuable assistance, but he also picked up the tactics of soaring with the greatest facility, a fact that must have helped him on returning to his own country. In any case he was the winner of the long-distance trial, making two flights, one of twelve and three-quarters miles and one of fourteen miles, the latter distance being a record for an American in his own country. On these occasions he flew the " Schloss Mainberg," which had been piloted by Hemmer during the preceding competitions in the Rhön. With these two splendid flights he secured the first prize in the long distance contest. One of the finest machines in the contests was the Akron Condor glider designed by Franz Gross, a former member of the Darmstadt Academy group. With this plane Jack O'Meara remained in the air for three and a half hours. Klemperer, the former pioneer of soaring in Germany and the present pioneer of the sport in the States, was unfortunate enough to have a crash, which forced him to retire from further participation.

The major share in the prizes, however, was taken by Hirth. His distance flight of thirty-one and three quarter miles constituted an American record. It was Hirth who carried out the greatest number of valid flights during the competition, taking off twenty-three times and remaining in the air for a period exceeding the half-hour on every occasion. He undertook flights of over seven hours' duration, reaching heights of three thousand feet. His long distance flight was completed by deftly exploiting

thermal currents. Hirth, whose sociable and sportsmanlike ways create friends wherever he goes, was also responsible for the idea of providing with food a fellow pilot who was up on a duration attempt, which he did by means of a three hundred feet fishing line. This method was also adopted during Hastings' record glide, and naturally soon found favour all round.

Six weeks after the end of this competition the Bowlus-Hirth Sailplaning school was founded in New York. Here, the ab-initio pupils were taught by the auto-towed method. In looking around for a suitable practice spot for this school, Hirth eventually, after extended "expeditions" in his light aeroplane, discovered the place he was looking for at Mount Peter, near Greenwood Lake. Here, on February 22nd, an icy cold day, he carried out his first soaring flight of two hours seven minutes' duration. The following day, accompanied by Jack O'Meara, the towing instructor, who used a Franklin glider, he remained in the air for four hours seven minutes.

Also about this time the Haller-Hirth Sailplane Corporation was founded in Pittsburgh, Penn., where, under the direction of Fritz Ackermann, the design and construction of high efficiency sailplanes on German lines was begun.

In every country records and competitions have quickly followed each other. A happy sign of the rapid growth of the British gliding community was given by the British Gliding Meeting on the 18th and 19th of October, 1930. Although the competition was only a small one, carried out within a short space of time, it set the example for many similar meetings, which have since been held in England. Admittedly the achievements did not reach the standard of other countries. However, such was not the idea of these contests. In Germany we would have rather styled them "training competitions." Whoever agrees that record performances are not material for future progress, but that the spirit of a sporting community is the chief thing which counts, will also know how to appreciate the comparatively small figures achieved during the competition held at the Ditchling Beacon.

Five prizes had been offered, mostly by firms interested in gliding, such as glider and "Dope" manufacturers. Unfavourable weather did not permit of notable performances, and this will explain why the best duration flight lasted only four minutes thirty-seven seconds. This performance was put up by Capt. Matheson of New Zealand, who had just obtained his "C" Certificate on the Wasserkuppe. Further pretty flights were made by Stratton in a Dagling, by Mole, and also by the Portsmouth "A" Team, and the Surrey "B" team. The flights of Matheson, who together with the Master of Sempill and Mole was a member of the "B" Team of the London Gliding Club, greatly contributed to the success of the meeting. The British-built machines, which appeared for the first time, also did very well.

Proof of the rapid progress of gliding was also provided by reports received from Australia to the effect that, even in that country, soaring was becoming more and more popular after Mr. Pratt had set up an Australian duration record on September 21st by remaining in the air for one hour thirty-five minutes.

In France, too, interest in gliding has been revived. Auger, who with Abrial had always devoted the closest study to the Rhön competitions, managed a soaring flight of twenty-eight minutes in his "Rapace," completing a closed circuit of eighteen and three-quarter miles whilst competing at a meeting in his own country.

Nothing much happened during the winter of 1930-31. A good flight by Jack O'Meara was reported from New York, the pilot in his Bowlus sailplane having been towed up by an engined aeroplane from North Beach, Long Island, to a height of three thousand eight hundred feet on February 12th. O'Meara then carried out a soaring flight over Manhattan. He was caught in a rising gust over the East River, lifting him to four thousand feet. After twenty minutes he landed on the aerodrome.

The many record-breaking flights carried out during the Spring of 1931 began during the first half of March. On the tenth of that month Wolf Hirth made a soaring flight over New York City. This effort is particularly noteworthy

in view of the fact that this flight was not carried out by means of aeroplane towing, Hirth simply used the hillside currents to overcome all the attendant difficulties of this type of flight.

Hirth had considered this plan for some time, and had carefully prepared his attempt. Having secured definite permission from the authorities on the very last day, he arrived at the spot he had carefully selected in the course of many tours in his engine aeroplane and his motor-car. This was a small park between the Hudson and Riverside Drive. The New York police force had sent sixty men on motor cycles and in cars. Riverside Drive was closed to all traffic between 150th and 170th street. The available space for landing was rather restricted, but Hirth made a splendid start, within a short time rising to a height of nine hundred feet, so that he would have been able easily to glide right along the bank of the river through New York. Unfortunately the police withheld their consent for him to do this. They finally signalled him to come down by waving red flags in order to free the roads for the traffic rush at the end of business hours. The flight was thus interrupted; nevertheless Hirth had convinced thousands of onlookers that soaring is a sport intensely worth cultivating. Hirth returned straight to Germany, where he took over the sailplaning school of Grunau. Under his able direction this school has since developed into one of the foremost German establishments of its kind.

Meanwhile the movement in Germany was busily engaged in carrying out tests with gliders in tow. The towing of motorless aircraft was admittedly not a new thing, the well-known stunt pilot Raab having previously demonstrated such flights during aerial displays, after Espenlaub had extensively studied the question. Moreover, in the preceding year the Rhön-Rossitten Gesellschaft had brought out a specially reinforced glider which had been flown by Stamer and Groenhoff on the Wasserkuppe. At that time I was taking an instructional course for the purpose of learning to fly in an ordinary engine machine. The "Darmstädter Akademische Fliegergruppe" had also initiated trials of towing normal high-efficiency gliders

behind suitable slow-flying powered machines. These tests had turned out satisfactory, so that flying activities on the Griesheim aerodrome near Darmstadt developed in a rapid manner. The power-driven aeroplane "Flamingo" of the Rhön-Rossitten Gesellschaft, a light aeroplane with a single engine of 110 h.p., took in tow alternately the "Fafnir" flown by Groenhoff and the Darmstadt gliders. A Klemm light aeroplane was also used for this purpose by the "Akademische Fliegergruppe." The advantage of the new method soon became patent, since a great deal of training could be put in even within a comparatively short space of time. After several short trial and practice flights had been made below clouds and along minor line squalls, it was hardly surprising that, the weather being favourable, on April 13th three of the training machines set out on a distance attempt after having been towed up to a height of one thousand three hundred feet. The pilots in question were Fuchs in the "Starkenburger," Stark in the "Darmstadt" and Groenhoff in his "Fafnir." The excellent geographical formation of the country along the "Bergstrasse" undoubtedly permits flights of between thirty-five and forty-five miles being carried out easily, seeing that a hilly range of even height extends from Darmstadt to Heidelberg. This range had been used by Nehring in the course of his trial flights for the one hundred kilometre prize. Nehring, however, had to take off under difficult conditions from a steep meadow on the lower half of the hillside and then work his way up with great skill. Towing simplified this troublesome task. However, Groenhoff's performance on that particular day was very splendid indeed. He succeeded in flying across the big gap separating the Odenwald from the Black Forest, and, whilst his fellow pilots did not exceed the forty-five miles limit, putting up performances something like Nehring's, Groenhoff landed not far from Freiburg, after having covered a distance of ninety miles.

This unbroken mountain range is also very well suited for distance flights to a given objective, though this can be done only with the wind blowing in a certain direction. On the other hand, being towed up offers the advantage of

permitting the glider to be taken to suitable weather conditions within a short time. In this manner Fuchs succeeded on April 15th in working his way along the range right up to Heidelberg, and returning to the place whence he started. The distance covered was twice thirty-six miles, a performance which surely proves the ability of this soaring pilot. Fuchs had taken an active part in the Rhön during the early years of the movement. He had also shown his skill in ordinary motor-driven aeroplanes, but now has taken up gliding again.

This rapid succession of individual performances spoke well for the future. In April, Hentschel, a police Lieutenant, had carried out a flight of over eleven hours duration at the Dörnberg near Kassel. All of us were convinced that the future would also bring distance flights doubling and trebling the figures achieved hitherto. Groenhoff's ability and skill, as well as his dare-devilry and pertinacity, were known to us all. To those of us who were aware of the fact that he had equipped his machine with blind flying instruments and that in his capacity as pilot of the Rhön-Rossitten Gesellschaft he had carried out towed flights practically every day, it was obvious that the next surprise could be expected from him.

The meeting of the members of the German Meteorological stations in Munich provided an occasion for demonstrating towed flights. They were undertaken by the Rhön-Rossitten Gesellschaft, who sent up Groenhoff in the "Fafnir" and Riedel to tow him in the "Flamingo." On May 5th about midday they started at Oberwiesefeld and worked up to a height of one thousand three hundred and fifty feet. In the rising current below a cloud Groenhoff soared to and fro over and in the vicinity of Munich, reaching heights of nearly six thousand feet. Meanwhile there had appeared in the south a huge perpendicularly banked up formation of clouds threatening a thunderstorm. For the time being Groenhoff flew towards Schleissheim, from where he could see the storm reaching Munich. It was difficult for him to recognize the course of the front of the squall. Anxious not to lose the opportunity of gaining considerable height, Groenhoff without a moment's hesita-

tion flew straight into the storm, where he was caught immediately in a very strong up-current. At the same time a terrific hailstorm, accompanied by intermittent squalls, began to make matters serious. The hail pierced the thin top covering of the plane. Hailstones and rainwater accumulated inside the wing. Fortunately Groenhoff managed to get out of the danger zone before his wing had been completely broken up. Growing more careful, he continued to fly in front of the line squall, which had now become plainly defined. In this manner he reached Regensburg, which he passed flying in a northerly direction. Meanwhile he lost touch with the storm, and he was forced to work his way up to a height of six thousand six hundred feet at the crest of a low-lying hill. This enabled him to pick up the storm front again, which now carried him across the "Böhmer Wald." As is usual, the storm abated towards the evening. Groenhoff saw the valley of the Eger beneath him, and having lost height considerably, also in view of the fact that darkness was falling, he decided to land. The latter part of the glide was again fraught with difficulties. Nightfall made it difficult for him to see the country below, and the flying qualities of the machine had been greatly impaired by the damage. Nevertheless a good landing was made, after a flight of eight and a half hours, Groenhoff having covered a distance of one hundred and sixty miles in motorless flight.

This effort had shown what could be done, even in flat country, after a towed start, for the Munich aerodrome is situated in the plains of Bavaria. In such places sailplaning had not been thought of before. The towed start permits high efficiency gliders being used from the ordinary aerodrome. This was corroborated by a flight from Berlin to Frankfurt on the Oder, by Fuchs on June 2nd. Fuchs, who had been demonstrating towed flights in Berlin, also started at the right moment in front of a squall. All the way the flight took him over flat country until he came down at Frankfurt on the Oder, a distance of forty-eight miles.

About this time I resumed my own gliding activities. Among the sailplane experts who had put up exceptional

performances I alone had not undergone a flying course in motor-driven aircraft, either before or during glider training. Not until the winter and spring 1930-31 was I given the opportunity of gaining experience in flying power aeroplanes. For this reason I did not resume my sailplaning flights until the beginning of June, when returning from a visit to my British friends. In England I had been able to study closely the method of towing by car, which had made rapid progress under the able direction of Lowe-Wylde.

The importance of this new method was obvious. In view of the fact that towing by car is particularly adaptable to flat country, and that its advantages become more patent where the country lacks suitable hills for soaring, I carried out fundamental tests on motor-car and aeroplane towing in Münster, Westphalia, where a large aerodrome permitted good heights to be attained.

About this time the Rhön-Rossitten Gesellschaft had equipped an expedition to the Jungfrauoch in the Swiss Alps, with a view to widening the knowledge on the formation of air currents between mountains, such as had been gained in the course of the winter of 1928-29 by my soaring flights at the Rax-Alpe. The expedition set out at the end of May, Groenhoff with his "Fafnir" being one of the members.

The lower density of the air at these heights created difficulties when taking off. Moreover the deep snow prevented the launching team from running. It was decided therefore that a team of twenty should form the launching crew. These difficulties had also occurred during the Rax expedition, when launching had been made possible only by stamping down the snow under foot, as is done on ski jumps at the beginning and at the end of the course. On June 10th, when launching the machine from the Jungfrauoch, the launching team failed to give the glider the necessary initial speed, and Groenhoff slid away on the skid at high speed without being able to lift the machine into the air. The sailplane nearly crashed down a precipice, but at the last moment he managed to take off from the ground. Groenhoff now found that his elevator

was partly out of action. During his slide down the hill one half of his elevator being near the ground had been torn off, so that its efficiency had been greatly impaired. Several times the machine got out of control, and the pilot was about to make use of his parachute. However, with the greatest skill, by rapid flying, Groenhoff managed to keep control and finally land safely near Interlaken. Besides this unlucky incident, the expedition was not favoured by the weather. It was therefore found impossible to carry out an extended soaring flight above starting level, although Groenhoff made several successful long glides. One glide he made, in order to attend a demonstration at the aerodrome of Berne, was of particular interest. On taking off he utilized the ascending part of the eddy, which is set up by south winds on the lee slopes of the mountains. After having dived through the down-current he then managed to reach the aerodrome by making use of a number of clouds.

A Swiss expedition, working on the same area and at the same time as the Rhön-Rossitten Gesellschaft, was more fortunate. On June 11th the Swiss pilot Farner went up in the early morning and carefully exploited the currents which are known to the mountain expert. For a few minutes he sailed over the Guggi glacier, and then took his glider to the Grindelwald valley, where he gained one thousand five hundred feet in height owing to favourable thermal currents. Farner landed after a splendid flight of one hour twenty-four minutes duration. On the following day Farner launched out again, hoping to use the thermal currents over the Lauterbrunn valley. He managed to keep his height for twenty minutes after having left the start. The Swiss expedition, whose members, having grown up in the mountains, were well versed in the geographical formation of the country, took two of their machines to the Scheidegg, where Baroni and Traxler carried out several more beautiful flights. Particularly worthy of mention, however, is a splendid flight made by Farner, who at the time was quite inexperienced in gliding. Flying along Lake Brienz and working his way across the Brüning Pass, he managed to cover a distance of 35.4 miles.

In several instances he had to recover height at various slopes. His distance was not far short of Groenhoff's thirty-six miles to Berne.

The Swiss novice Soltein carried out the last flight of the expedition. Over Interlaken he rose to a height of four thousand six hundred feet, probably carried up by thermal currents, finally landing after thirty-five minutes.

Both the Swiss and the Rhön-Rossitten expedition confirmed the experience made by the Rax expedition. In the mountains rising currents are not nearly so active as had been assumed. Eddies are, however, particularly strong. Results are likely to be achieved mainly by using thermal currents. Of course, great care and a good knowledge of the peculiarities of the mountains are necessary conditions for successfully carrying out such expeditions. As early as during the Rax expedition I had put forward the opinion that it ought to be possible to soar permanently in the ascending part of the eddy set up on the lee side of mountains. This has as yet not been done. In the event of another such expedition it certainly would be worth while to study these currents and to attempt soaring on that side of the mountain where we have hitherto assumed the existence only of down-draughts.

Whilst Groenhoff was flying at Jungfrauoch I was engaged in preparing the first large scale demonstration of soaring over flat country. My intentions were to arrange an aerial display in Münster on June 14th. In the midst of my preparations I heard from London that the *Daily Mail* was offering £1,000 for the first glider to cross the English Channel both ways. It was very awkward for me to leave Münster in time. However, on the day before the competition was due to begin I arrived at St. Inglevort. German and English newspaper reports had led me to expect strong competition, for in accordance with German reports Groenhoff and Hirth had entered, whilst from England Lowe-Wylde, Squadron Leader Probyn with Turner, and Flt.-Lt. Findlay with the Lyons Tea machine piloted by Krause were expected to arrive in the course of the first few days. Mr. Lissant Beardmore, whose enthusiasm for gliding had been roused by my demonstrations

in England during the previous year, and who had acquired a German high efficiency sailplane of the "Professor" type, was engaged in towed flight tests. For these reasons I was convinced that the character of the competition would very likely differ in actual practice from what had been originally intended. In view of the fact that towed flight was to be permitted I was sure that the contest would turn out to be a kind of towed flight race, perhaps the first one of its kind in the world.

Competitors were allowed to start after noon on Saturday, June 20th. Owing to unfavourable weather conditions, however, nothing could be done until late in the evening. Apart from the weather, a difficulty that presented itself was the shortness of the available time. The French coastal stations reported a strong head wind. The sporting attraction of the whole venture was increased by the fact that low hanging clouds covered the sky until immediately before the start: in addition to this it was impossible to await the latest weather reports. Owing to the late hour the return flight from Dover Hill had to be undertaken at night. Whereas on the way out I had required the whole of the nine thousand feet to reach the other side owing to the head wind and the down-currents over the English coast, I lost only three thousand feet on my way back, so that I still had six thousand at my disposal when I again arrived on the French side. I landed on the illuminated aerodrome of St. Inglevert.

THE ENGLISH CHANNEL FLIGHT

THE English newspaper, the *Daily Mail*, must be given the credit of having been the first to direct the interest of the public to any extent towards one branch of the sport of flying which is gradually assuming a more important position—Aeroplane towed flight.

In Münster, I received information, that the *Daily Mail* had offered a prize for the first double crossing of the English Channel in one day. I had to conclude the preparations for my soaring flight on June 14th. On the twentieth, the competition was to begin. I also wished to bring my new giant sailplane, the "Austria" with me, which would have made such a flight possible, even against the wind, circumstances which might not have made a crossing possible with the "Wien."

On the sixteenth, I attempted the first start with this giant bird in Münster. At that time, I had not yet the under carriage which could be dropped, our small Klemm aeroplane of 80 h.p. did not, however, get "Austria" into the air. In order to overcome the ground friction on the skid, we attached a Mercedes lorry by a cable nine hundred and eighty feet long, and our small Klemm to a cable three hundred and sixty feet long, and thus there came about what was probably the first combined auto and aeroplane towed start. The machine was then dismantled and packed up, and rapidly driven by my friends over the roads of Germany, Belgium and France, to St. Inglevert, the aerodrome of Calais. It was the Belgian Minister of Transport—Lippens—who, in a wonderful manner smoothed over all the difficulties during the journey through Belgium. The French Embassy in Brussels also did everything to facilitate the journey through France.

When we arrived at St. Inglevert, we heard of the preparations in England. Mr. Lissant Beardmore had developed an excellent towing device, in which, in the same way as

the Americans, he had fastened the cable round a cable drum on a power-driven aeroplane, and could thus regulate the length of the cable. He had also provided telephonic communication between the aeroplane and the sailplane. Beardmore was at this time at Lympne, and we met there when I flew over with the Klemm in order, as quickly as possible to ascertain the possibilities of landing in England. Hans Werner Krause had been flying for the Lyons Company during the whole summer. In consultation with me, the latter had arranged gliding demonstrations over the whole of England; whereby, on the one hand, the English gliding movement was given a really good stimulus, and, on the other hand, the Lyons Company had received a large amount of publicity. As a towing aeroplane, the Lyons people had a Moth with Flt.-Lt. Max Findlay, chief instructor of National Flying Services, Ltd., as pilot. Mr. Lowe-Wylde had even brought out his excellent B.A.C. VII, but it was particularly unfortunate that his towing aeroplane was not ready until it was too late. On June 18th, Mr. Turner had been towed to an altitude of ten thousand feet by Squadron Leader Probyn, Commanding Officer of the Royal Air Force Station at Hawkinge, with his "Westland Widgeon" in forty-five minutes. Turner then managed a glide lasting thirty minutes.

After the publicity in the papers, Wolf Hirth and Günter Groenhoff were also expected to arrive. We expected their machines any moment.

An exact programme was made out by the British Gliding Association, who were responsible for the management of the competition. The towing cable had to be slipped two miles inland. Barographs had to be taken. Noon on Saturday, June 20th, was arranged as the earliest time for starting. On the previous day, Mr. Beardmore started from Lympne with his "Professor," in tow of an Avro 504K. He had not warned the B.G.A. of his start, so that he could not be observed. His official start at Lympne was given as 5.30 p.m., and his landing time at St. Inglevert was 6.03 p.m. Beardmore announced that he had been towed to a height of twelve thousand feet, and had then flown free over the Channel. He was lucky with his flight,

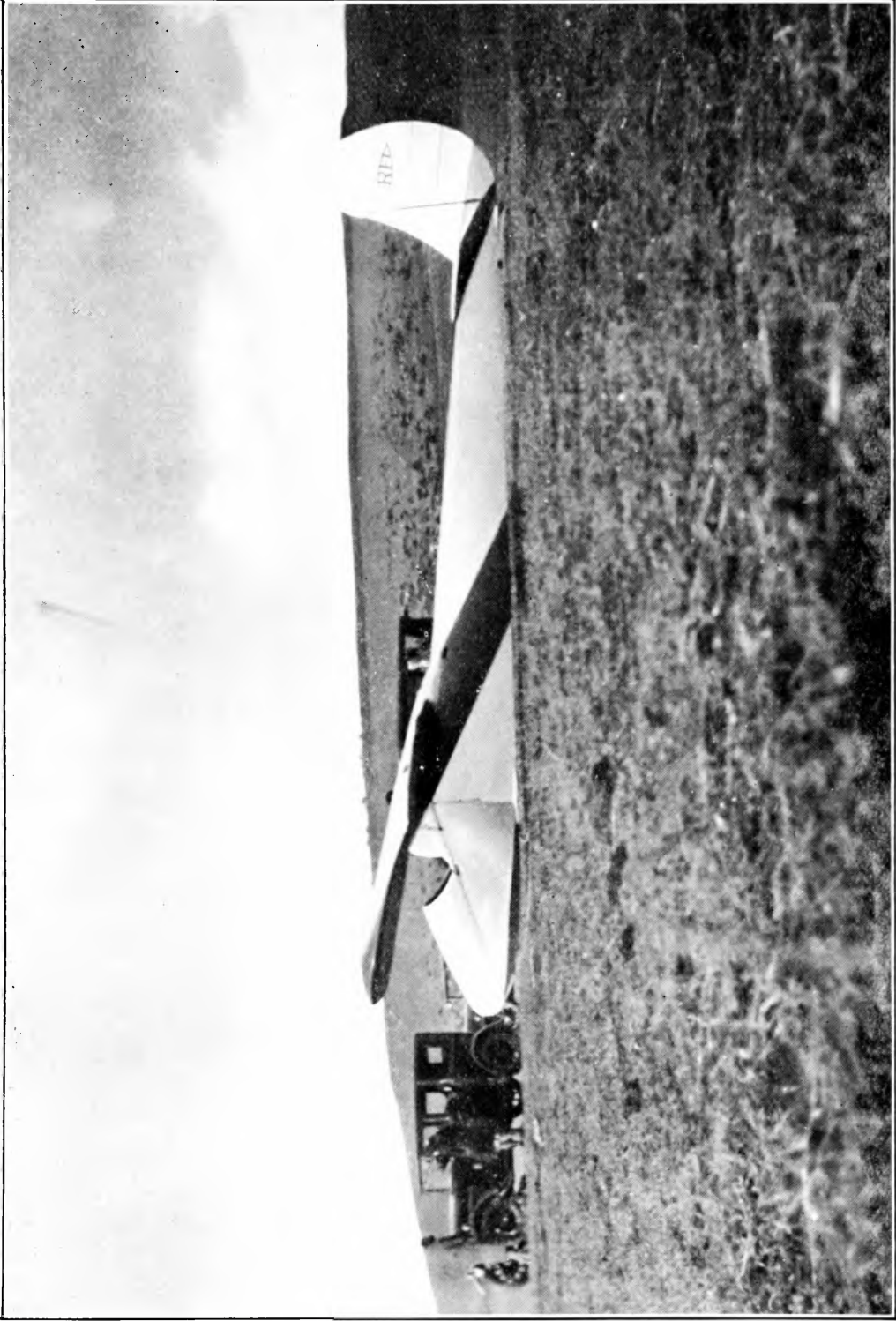

87. THE R.F.D. SAILPLANE. Span 14.6 metres.

BUILT BY R. F. DAGNALL OF GUILDFORD AND DESIGNED BY J. BEWSHER.



88. THE HUGE SOARING PLANE "AUSTRIA," IN FLIGHT

in that he had the most beautiful weather and a strong following wind. As he had flown without official observation and before the commencement of the competition, I assumed that he—as also Turner—had crossed over to start in the competition under the same conditions as the others. It is a pity that he did not do so. A victory in the general competition, sponsored by the B.G.A., would have been acclaimed enthusiastically.

Early on the morning of June 20th, all participants were on the spot. The last remnant of work on the machines was being done feverishly, in order to be quite ready for the official start of the competition at twelve o'clock.

The sporting character of the flight has frequently been falsely estimated. On the basis of its programme, the flight was, and will always remain, the first combined towed and gliding race in the world. The sporting value was different to that of a normal soaring flight. With the latter, the skill of the pilot and his machine are of supreme importance: with power-driven flights, the skill of the pilot, the quality of the machine and engine: with a combined towed and gliding flight, all these conditions are lumped together. Even towed flying has its difficulties, and must be learned. The *Daily Mail* Prize showed this for the first time by its great publicity. Later, we often experienced it.

The B.G.A. observers were on the spot, as were also Turner and Krause; but the weather was bad. The tension increased towards 11.30, as the pilots had their machines brought out on to the ground. In spite of every endeavour to find a gap through the wall of clouds by sending an aeroplane along the coast, a start was impossible. Both Flt.-Lt. Findlay and Krause, as well as Weichelt and I, who had made a reconnaissance with our aeroplanes, had to abandon the idea of starting, because the clouds were everywhere too low. During the afternoon, it cleared slowly, and the weather reports from the English coastal stations reported a diminution in the strong adverse wind which had been reported earlier.

Towards 5 p.m. a slight nervousness showed itself in the various groups. The initiated could feel that preparations

for a start were being made in the hangars. Actually, the Moth of the Lyons group was brought out and was taxiing along the ground. Almost immediately, Krause's helpers brought out his machine. Hardly was it erected on the starting place, than the "Wien" was hurried past it, to take up a position behind the "Klemm," which was even more quickly brought out. The race started. As a result of my towing machine being weaker by 30 h.p., I was at a very great disadvantage as compared with Krause, and this was at once evident. The towing cable was attached. Two men pulled in the centre to assist; two others were at the wing tips of the "Klemm." The throttle was opened wide. The "Wien" followed slowly. Then sliding more and more quickly it rose and soon followed the still taxiing aeroplane into the air. The start went off excellently. Slowly we flew straight ahead, then made a wide turn and climbed higher. Krause only got this far five minutes later. His more powerful towing aeroplane then made itself felt and I saw the machines underneath us coming closer with extraordinary rapidity. Weichelt, usually so calm, signalled to me from the front out of the "Klemm" that we had risen six hundred to nine hundred feet above the Lyons people, to an altitude of five thousand feet, thus half the height we required for the flight.

At six thousand five hundred feet there was a dense bank of clouds over the Channel, which cut off the coast and over which we endeavour to climb, getting in the process heavy jerks in the towing cable. It was there that Krause apparently no longer had control over the situation. According to the report of both the pilots, there must have been a few really anxious seconds for both the machines, until Krause decided to slip the coupling and give up the first attempt. I saw him from above disappear as a small point. According to Krause he would have jumped if he had had a parachute with him. His effort was none the less great. He who knows "Hans Werner" knows that he gives of his best in any sport.

We therefore gently climbed still higher, and from time to time the ground disappeared behind the clouds. In the meantime, Krause again tried to gain sufficient altitude,

but had to abandon altogether after the third attempt, because the towing coupling had snapped.

From a sporting point of view, I thank Providence that the flight over the Channel, which is so simple in fine weather, had become a really difficult undertaking owing to its character as a race and the consequent impossibility of choosing favourable weather.

On the ground, we had had a strong east wind, but, from what I could feel, I think I can say that at ten thousand feet we had a wind in exactly the opposite direction. Through the hurry at the start, I had to leave a few minutes before the promised upper altitude wind measurement had been announced.

About 6 p.m. I slipped from the aeroplane, cautiously making certain that the proceeding could be observed from below.

Below me were clouds, and through the small and isolated gaps were the white tops of the waves. Half an hour later, nothing but clouds and water. Unless I had erred in my estimation of the speed of the wind, which I could only make from a sense of feel, I was somewhere in the English Channel. At last I saw a small dark point under me through a hole in the clouds : the Varne Lightship. A glance at the chart showed me that I was almost thirty degrees off my right course. Still, there was nothing to be seen of the coast. The sun was against me, and England still lay in the mist, in spite of the fact that the clouds were disappearing. Finally, a glittering strip appeared on the sea, which I took to be Dover, so I held on towards it. As a result of the strong headwind, I had lost more height than was anticipated. If I could not reach the coast, I was going to land the machine on the stone breakwater of the harbour, as gently as possible. In this way, I should have at least complied with the wording of the instructions—not to have landed in the water. There were a few anxious minutes, but they soon passed and I landed in the field which Miss Lippens, the Belgian aeroplane and glider pilot, had pointed out as the only landing place, the last moment before my start. To her, therefore, I offer my thanks for the success of this flight.

It had taken me more than an hour against the wind from the time of casting-off above Cape Gris Nez to get to the English coast.

To my astonishment, I met on my landing-field Krause's assistants, who were waiting there for their own pilot, and who were a little disconcerted when I appeared in the picture instead of him. In the most friendly manner, they helped me, and even lent a hand for my next take-off which took place shortly after 9 p.m.

Even before the take-off from Dover Hill, it was markedly dark, but I absolutely had to return the same day. Over the Channel, there again lay some mist, though the clouds had disappeared, and it was a peculiar feeling to fly into the blue-grey ; but Weichelt was still with me.

In England, we were not able to obtain the correct Petrol-Benzole mixture for the "Klemm," so we decided that Weichelt should tow me as high as his fuel would allow him, and then he would land by gliding. As a true friend, he held on right to the end. We had not even reached ten thousand feet, when I felt a strong jerk in the cable, showing that the engine was beginning to give out. I immediately cast loose and set off alone over the Channel. It was so dark, that I was unable to distinguish the lines on my compass any longer, but feeble moonlight shone over the edge of my right wing, and I took my bearings of the shadow with my head turned half-right. It was not easy, because this prevented me from keeping my attention on the French coast, and soon it was impossible to see anything. Only the moon was my companion. At last there was a flash below me, which I decided must be the lightship in the middle of the Channel. There were also other very small stars below, but it was difficult to distinguish from the whole grey outlook whether I was yet over the French coast. The clock showed twenty minutes since casting off and I was still six thousand five hundred feet up. Below me the lighthouses of Calais and Boulogne were sending out their shafts of light through the night and very feebly I could distinguish the landing lights of St. Inglevert. It must have been peculiar for those awaiting me, to feel that I was circling high above them, and yet they could not



89. A MOTH (CIRRUS III ENGINE) FITTED FOR TOWING GLIDERS AND USED BY
NATIONAL FLYING SERVICES, LTD., FOR THEIR DEMONSTRATIONS

By courtesy of "Flight"

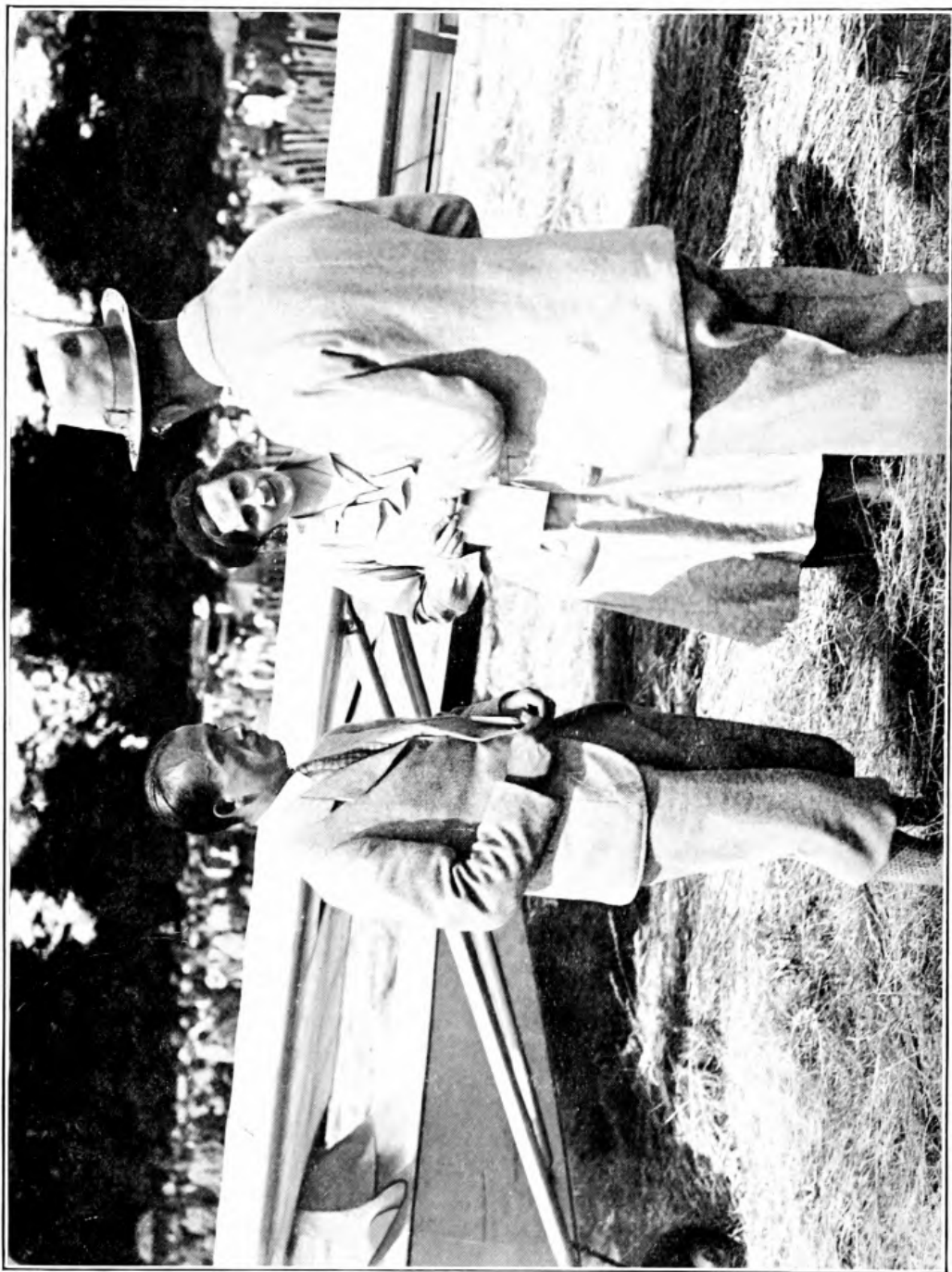

90. HERR KRONFELD (left) AND MISS SUSIE LIPPENS, THE WELL KNOWN
BELGIAN LADY GLIDER PILOT, AT HANWORTH PARK

see me. Then I began to spiral down, and took a long time, until I had lost all my height. The actual landing by night gave me no trouble at all.

As to the jubilations after the landing, I need report nothing. It has been sufficiently done from other quarters.

It was as if the era of the towed flight had now really begun. On the day that I flew across the Channel, Mole flew the B.A.C. VII "Barbara Cartland" from Maidstone to Reading, being towed by Mr. Wanliss, thence, accompanied by five aeroplanes, they went to Hanworth. I myself received while in Calais an invitation from the King and Queen of the Belgians to demonstrate soaring flight before them. In the short time available, this was only possible by means of a towed flight from Calais to Brussels. The Belgian Royal couple showed an interest in my flight, and a degree of kindness which was unsurpassable. On the Brussels aerodrome, I demonstrated both auto and aeroplane towing, while good thermal conditions facilitated my flights. It was a pity that I could not stay longer. There was a short demonstration the next day for the Belgian club, and then a journey direct to London in tow, with a short intermediate landing at Calais, this being the longest towed flight which had up to then taken place on the Continent.

MY SOARING FLIGHTS OVER LONDON

THE magnitude of any stimulation can best be learnt from its effect. The *Daily Mail* prize had, as a further result, my thermal flight over Hanworth, my flight thence over London to Chatham, and back again the next day. As these flights were carried out in a practically dead calm and over flat ground, I believe that they may be stated as being the first really extended flights undertaken purely thermally.

The first flight was an hour's flight, which I was able to carry out on the occasion of the great official English flat-country gliding demonstration at the London Air Park, Hanworth, so wonderfully organized by Colonel the Master of Sempill. Towed to an altitude of one thousand five hundred feet by Weichelt, I was able to sail for a long time in the upward current of thermal cumulus clouds. The only difficulty which existed was that, owing to the wind, the clouds drew away from the spot, and, in order that I might remain in sight of the public, I had constantly to travel from one cloud to another. When I wished to turn back to the aerodrome I had to push through downward currents of three hundred feet per minute. The lowest altitude to which I was forced as a result of this was one thousand feet, whence I could again work upwards. In general, I gathered the experience that, on days when strong upward current streams are available, downward current streams also appear, their speed approximately balancing each other.

The experiences gained from this flight I was able to use in my flight to Chatham on June 30th. On that day, there was practically a dead calm, with a light head wind on the latter part of the flight. I had originally intended, if possible, to soar from Hanworth below the thermal cumulus clouds towards London, and to soar for a long period in the thermal up-currents above the City. After

I had been towed up by Flt.-Lt. Max Findlay in a characteristically careful and cautious manner, in spite of the gusty weather, to an altitude of about one thousand two hundred feet above the start, I cast-off, and continued to climb almost continuously to an altitude of nearly four thousand three hundred feet. In view of the particularly lively cumulus activity, I was able to remain at a height of four thousand three hundred to three thousand feet for a long time, following the course of the Thames, and arriving in the neighbourhood of London. Just previously, however, I lost a considerable amount of height, and came down to one thousand two hundred feet, whence I was only able after several attempts to reach a strong upward-current region. This was very noticeable in the steep curve of the barograph. The climbing speed of 5 ft. per second was attained, which corresponds approximately to the up-current energy below the thick cumulus clouds found behind typical depressions. The purely thermal cumulus clouds found during this flight, however, had neither the height nor the width which are associated with such conditions. Directly over London, the flight became much more difficult owing to particularly bad visibility. Good visibility is absolutely necessary in cloud flights, in order that further groups of clouds and formations may be recognized. It became hardly possible to do this, so that the flight became really unsafe. Unfortunately, the barograph stopped after about two hours, so that further altitude curves could not be followed. In any case, the greatest height reached can be taken as four thousand three hundred feet. I reached this about two miles south of the Thames, over central London. It was a peculiar feeling, to be cruising high over this enormous city in my "Wien." Below me roared the traffic; the factory sirens, the sirens from the steamers in the Thames, and the horns of the cars, could all be heard from my height, sometimes, loudly sometimes feebly. In the effort to reach as great a height as possible, on account of the uncertain possibility of landing, I shortly entered a cloud, but was not able to break through it. When I had regained my visibility, I was, in my estimation, somewhere towards the south-east of London, and I continued the

flight in the same direction, until I was compelled to land at Chatham towards the evening, owing to the ceasing of the cumulus activity. In the clear sky, I could still clearly trace out the thermal activity over the houses in the town itself, before I made a landing on a very nearly ideal field, which was filled with innumerable people immediately afterwards.

I am indebted to the incredible kindness and tremendous help of Admiral Snagge, for the fact that, with the assistance of his men, I was able to dismantle the machine and carry it away on a lorry, without using my own trailer.

The next morning, the machine was again assembled on a suitable site for a towed start. During the three and a half years' life of my "Wien" this is the only case in which the machine was transported without its own trailer, and yet it was not damaged in the slightest. This is certainly a proof that "the Navy can do anything." I was again towed up underneath the first best cumulus cloud by Flt.-Lt. Findlay, who is a master of the art of towing and can be trusted by anyone without fear. Unfortunately, I misinterpreted the warning which the cloud gave me by the ragged ends hanging down from below its base, which is normally a sign that the cloud is dispersing. I cast off, and from that moment continuously lost height, until I was, to my horror, at a height of not more than six hundred feet above the starting point; whence, after having very nearly abandoned the idea of a further flight, I was able slowly to work up to one thousand feet, but only then to lose height again to about five hundred feet. Continuously occupied in looking for a landing place, I arrived over a cornfield, which reflected the heat of the sun, and over which a strong upward current was noticeable. I made use of this, immediately flying in climbing spirals. In this manner I was able to make contact with a large cumulus cloud, which was in course of formation in a dead calm between Wrotham and Otford. In spite of the up-currents being much more feeble than on the previous day, I was nevertheless able to reach three thousand feet, and, moreover, to my knowledge, for the first time in the history of soaring flight—to find my way back to Hanworth

by the aid of map, compass and course of the clouds. This is an undertaking which I had not believed possible. In order not to lose my chances in the bad visibility over London once again, and on the other hand to utilize to the full my altitude in the event of the flight failing, I worked my course towards Biggin Hill aerodrome, which I saw lying to the south of my course. I reached Croydon at a height of one thousand five hundred feet, after my barograph had again stopped by a failure of the clockwork. Over Croydon, I worked up to an altitude of three thousand feet in half an hour's strenuous activity. Then, thanks to the line which I found drawn between Croydon and Hanworth on the map borrowed from Flt.-Lt. Max Findlay, I arrived at the London Air Park at a height of one thousand five hundred feet.

Thermal soaring above all!—a new sport! The naturalists in the tropics had called this “sun soaring” in the case of birds. The Rhön competition, which followed this flight, brought into play the greatest efforts; but even after I had landed in the London Air Park, I wrote: “What we in our conception had held as impossible has succeeded—flying overland in pure thermal currents. We are now at the beginning of a sport in which experience, knowledge and sense of feel count for everything.”

MY SOARING FLIGHTS IN ENGLAND

THERE are several ways of profiting from the performances in every sphere of sport. One can value the purely sporting side highly or one can consider the actions of individuals as affecting everyone in general. My work in England will always bring me the most precious memories and I hope that I was able to give the young Soaring Flight movement in England some useful stimulation.

The first meeting, which was held under the auspices of the British Gliding Association, was that on Itford Beacon. Messrs. Woolf and Lucas of the Piccadilly Circus Garage had arranged the tents and marquees and done everything possible to make things easy for the gliding pilots and the visitors. Since the first English meeting in 1922 no such gathering had been seen.

The first possible flying weather was awaited with suspense. The site was ideal for winds from the north. But the slopes to the west and south were not steep, making conditions very difficult when the winds were from the south-west and south. Nevertheless I maintained that soaring was always possible with such a high performance machine as my "Wien," At the same time there was the young pilot, Magersuppe, from Kassel, who was flying for the *Daily Express* by which paper he had been brought over to England. He assembled his "Professor" and together with members of the English clubs who had arrived with their machines was soon in the middle of a brisk interchange of reminiscences and questions but there was insufficient time to settle all the points raised. On the third day of my stay in England I had an invitation from the Maidstone Club to deliver a lecture before their members and the interest of my audience showed me that still more such important work awaited me.

My first flight was made on Tuesday, June 3rd, in a light wind from the N.N.E. during the quietness of the evening.

This flight showed me how suitable the terrain was. The following day I again soared in my "Wien" with the help of a west wind and reached a height of three hundred feet above the starting point. On June 5th we had to move our starting place to West Firle Beacon owing to the wind having gone round to the east. Those who witnessed my flights on this day were representatives of the aeronautical press and press photographers.

The British Gliding Association had before and during this time done good work. Their indefatigable Mr. Gordon England took me then to Portsmouth where a Gliding club was being formed. Once again I experienced the great interest which English people were beginning to show in motorless flight and was also received with the same enthusiasm and friendliness extended to me not only on my arrival, but also later on everywhere I visited.

Saturday was the first official flying day. The Master of Sempill, who never seemed to tire, hurried down from London to help and organize everything. During the whole meeting he was at hand and gave us assurance that the arrangements were such that it would be a success. In the early morning Magersuppe started flying in a strong north wind and later in my "Wien" I wandered up and down the steep slopes of the South Downs over the storm-beaten spectators.

During this time the many zealous members of the London Gliding Club had assembled their "Prüfling" and they allowed me to fly it after I came down. Directly after me came Captain Needham, who with a flight of an hour in the same machine gained the first "C" pilot's licence in England. It seemed that these flights broke the ice, for after this flight followed flight. A few minutes later Marcus Manton was in the air and he also succeeded in gaining his "C" certificate. So it went on, and while Buxton was flying for his "C," Captain Needham managed to keep a "Zögling" in the air for twenty minutes. This flight above all showed what an excellent site for up-currents this was.

At 5 p.m. I took-off once more in the "Wien" in an endeavour to reach to up-currents beneath the clouds.

The altitude of the slope at the point where I took off for this cloud flight was six hundred and twenty-four feet and I reached a height of over two thousand feet above the starting point. This showed that from even such slopes it was possible to reach the desired up-currents. In this way it was also possible to fly some four and a half miles straight out across the flat land and then again still to be able to glide back to the starting point. This particular wind direction made it impossible to carry-on with the clouds, as they were going out to sea.

Whit-Sunday brought with it conditions suitable for a training course for the numberless cheerful crowd of Gliding Club members. The wind was too strong for absolute beginners and therefore gliding on the "Zögling" was confined to those pilots who had already had experience on power-driven aircraft. In this way we gathered a great deal of experience and the position was such that there was little difference between the spirit found here and that which ruled at the Wasserkuppe. Thousands of spectators arrived and one machine started after another, some soaring on the steep slopes, others gliding lower on the hillside. On this day also Captain Fox-Barrett secured his "A" licence and the Master of Sempill his "B."

Whit-Monday arrived with only a light south-westerly wind. This was the opportunity for Lowe-Wylde to bring out the "Zögling" which he himself had designed and constructed and soon he was the most "flat-out" person present. At first it was quite impossible to soar, but later a little more wind sprang up which made it practicable to do so from the short south-west slope. This weak wind meant that only low altitudes could be reached, but this made it all the more interesting for the spectators, especially so as the flying was all explained to them by Mr. Gordon England. Representatives of the Royal Aeronautical Society were also present and helped to awaken interest in this new sport.

It was a pity that this wind was not stronger. Already I was waiting to do what certainly sooner or later someone will manage, namely to use the rising currents from the Downs which run parallel to the English coast. It is certain



91. HERR KRONFELD'S "AUSTRIA" AT ILANWORTH PARK. THE LARGEST
GLIDER IN THE WORLD.

By courtesy of "Flight"



92. THE "AUSTRIA," VIEWED FROM BELOW. A MACHINE WITH A SPAN OF 90 FEET

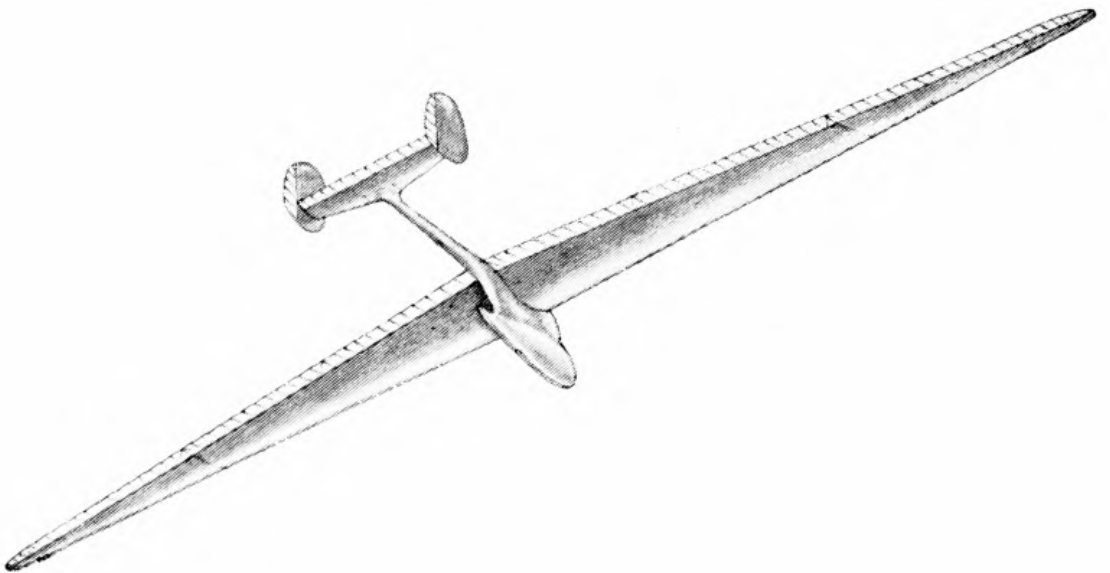

93. DRAWING OF KRONFELD'S "AUSTRIA" IN FLIGHT

that when the sun's rays are strong one should be able to reach the clouds and by this means make a long flight.

On Saturday, the 14th, the afternoon was again devoted to flying, both in the "Prüfling" and the "Zöglings." The Master of Sempill and Mr. Gordon England hurried down from London in order to spend the week-end with the party on the Downs. Many "A" and "B" licences were the result of the instruction which Captain Needham gave throughout the whole day. My chief aim was, however, that several "C" licences should be gained, and it was with great pleasure that I heard the Master of Sempill mentioned as the first candidate. First of all I myself made a flight as for the "C" licence on the "Prüfling" and the Master of Sempill following me put up an excellent show along the steep slopes of the Downs.

Thereafter in my notes of the flights I said :

"Looked at from the point of view of the instructor, this was the best 'C' test. The pilot paid attention to all he had been told, flew in a disciplined manner, without making any unnecessary experiments or stunts."

The Itford Hill site was certainly the most successful used during my time in England. Nothing was forgotten and the life was certainly the right one for soaring pilots. During these days a genuine beginner who had never even sat in an aeroplane before was taught to soar with the "Zögling," whilst Magersuppe soared above the Downs.

So it went on until late in the evening, the motor-cars drove away and the Downs became stiller and stiller leaving us alone with our "Birds" which we finally took under cover into the tents, ready for further work in England.

Right early a great difference between the German and English gliding movement made itself very plain. In Germany gliding is a sport for the younger generation who through tenacity and zealousness endeavour to compensate themselves for the help and assistance which the well-to-do classes have at their beck and call. Also until lately gliding and power-driven flight were antagonistic with very little in common. England has the leaders of her gliding movement to thank for the fact that this isolation

of the younger generation has been avoided. I remember that during those days we were visited by members of all classes of society, as well as from every branch of flying. For example, Lord Gage, who owned the land upon which we were flying made his first flights in a "Zögling." While Flight Lieutenant Stainforth the "fastest" man in the world will, I feel certain, not forget the slowest flight he has ever made in his life when he flew a "Zögling" on Itford Hill. All the most important English people in aviation were there, so many that I cannot remember them all. I trust, therefore, that those whom I have forgotten will forgive me when I merely mention that Sir Alan Cobham and Lady Bailey were on the Hill, whilst C. G. Grey smiled as he watched the efforts of the young generation on the site on which he had flown long before.

Sunday brought with it an E.N.E. wind and it was therefore by no means easy to soar close by our position. With a "Prüfling" I obtained all kinds of experiences of the influence of vortices which from time to time were shed from behind the spurs projecting northwards from the slope. During the afternoon of this day I had the pleasure of demonstrating to the late Sir Sefton Brancker, the then Director of Civil Aviation. I then realized why, as I had noticed immediately on my introduction to him when landing in England, he had the respect of and was in sympathy with everyone in connexion with aviation.

Everyone will have noticed that my chief aim was to make long cross-country flights and that it was hard for me to confine myself to making flights up and down along a slope. Therefore, late in the afternoon when the public had started to go home, I asked Mr. Gordon England whether I could go wandering. He is always enthusiastic to further the knowledge of soaring flight and therefore agreed to my doing so. I had intended to start about 4.30 p.m. but I had to make another flight instead of Magersuppe as he had landed his "Professor" in the valley and had yet to bring it back to the starting ground. It was therefore already 5.30 p.m. before I could get away and unfortunately the wind was dropping and the air much cooler. The first part of the flight was for gaining altitude over Firle Beacon, as before me lay the problem of getting across the two-and-a-half-

mile-wide valley to Cliff Hill. Mr. Gordon England, who, with the late José Weiss was one of the pioneers of English gliding, stood on the starting ground and explained the flight to those who were following me. They could see how I gradually lost height as I glided across the valley until I was hidden from view by a spur of the Cliff Hill. After a few, what were to them and to me, alarming minutes, I began to climb and on top of a strong up-current caused by the best soaring slope of the whole district I quickly gained height and got over the next large valley by Lewes. North from Brighton, the Downs begin to bend to the south and it was very difficult to retain my height as the N.E. wind was blowing almost parallel to the slopes. Again I managed to get over a valley three miles wide to the next chain of hills but the sinking wind made it more and more difficult to carry on.

There was still another valley to be negotiated which, owing to the low altitude attained and the absolutely cloudless sky, required entirely different tactics to those employed in the Rhön district. The flight further on to Petersfield presented no real difficulties. It was not until I reached there that I began to think about my further programme, but I had to do so then as it was already past 8 p.m. and not only the visibility but also the strength of the up-currents was getting worse rapidly.

It would probably have been possible for me to have extended my flight by another ten to fifteen miles to Winchester, but to have beaten my World record flight so late in the evening would have been impossible.

As it was intended to move with the machines to Portsmouth the next day I resolved to make the flight to a fixed point and land, if possible, at Portsmouth. To attain this object a flight over ten miles of level terrain had to be made, there being only a few small hills and coppices to offer up-currents. The chief difficulty was, however, to determine the exact position of Portsmouth, for I had not had time to prepare the flight and therefore knew nothing beyond the fact that Portsmouth lay to the south. As the wind was very feeble I only cleared the last small hill near Petersfield by three hundred feet, with the help of its up-current. In view of the noiselessness of my flight and the advanced

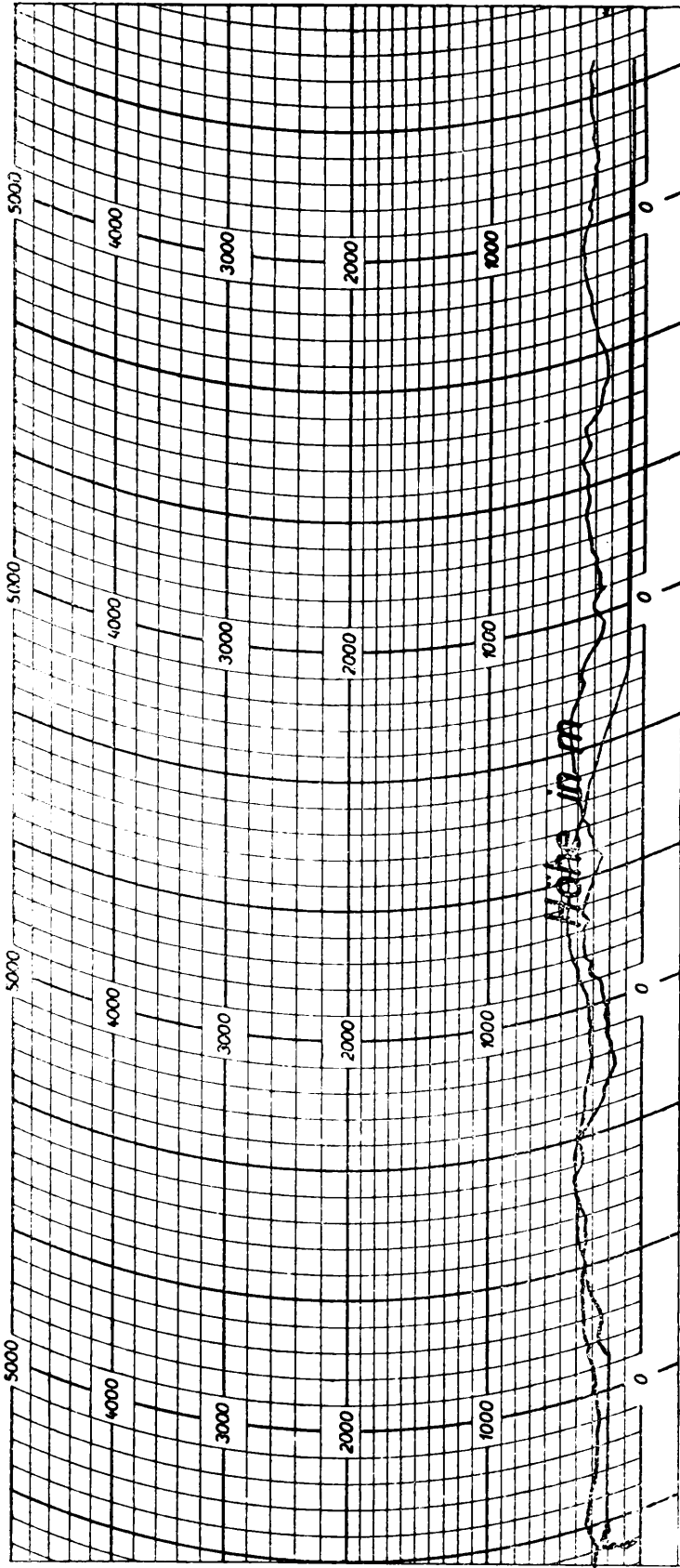

BAROGRAM OF FIRST LONG DISTANCE FLIGHT UNDERTAKEN IN ENGLAND

ITFORD HILL TO PORTSMOUTH ON SUNDAY, JUNE 17TH, 1980

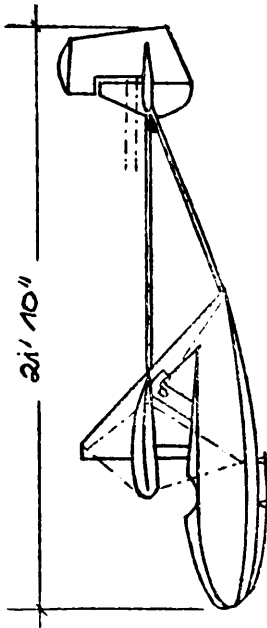
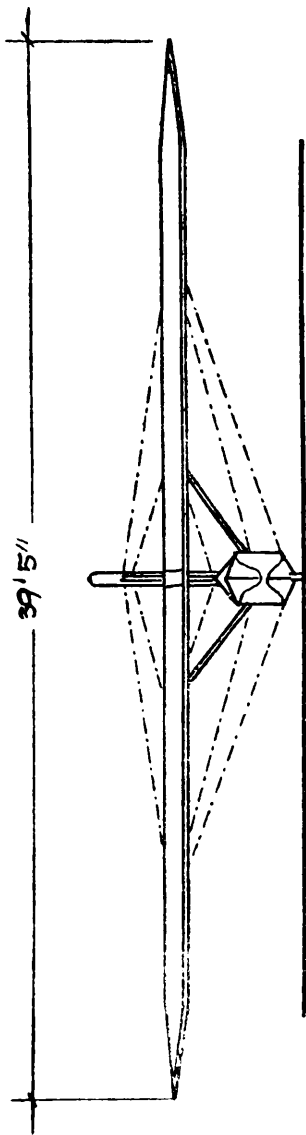

HANGWIND

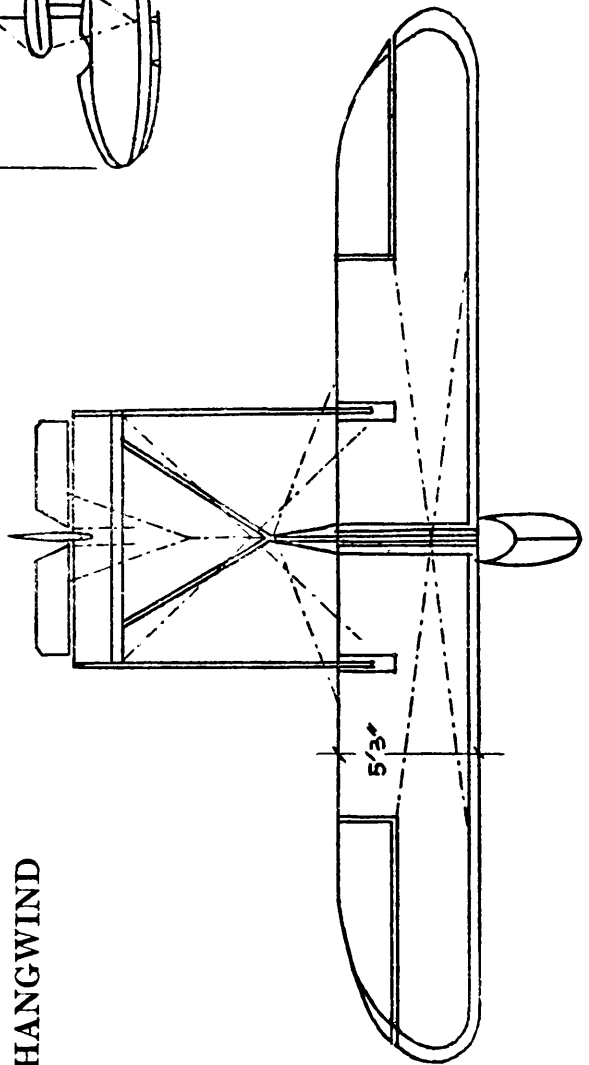

evening hour it struck me that I was very indiscreet in flying over a small wood swarming with courting couples. I imagine that it was not exactly considerate of me to call out at the top of my voice "Where's Portsmouth?" A man called to in this manner first turned round three times trying to find where the voice came from and at last looked up into the evening sky where I circled. He then pointed out the direction. I confirmed this by observing the thick motor-car traffic on the road and directed my flight in the direction indicated, alongside the road and railway. Portsmouth was still out of sight as it lay down behind the Downs. I got over Portsdown Hill at a height of fifteen feet and just had sufficient time to glance at the town with its swampy outskirts lying beneath me. A descent there did not seem advisable so I circled back and landed on Portsdown Hill itself. In certain respects the flight resembled my sixty-mile one in the Teutoburger Forest, the height conditions were about the same but the valleys were larger. The right-angled turn over the ridge near Petersfield was necessary owing to my determination to land at a fixed point.

The assistance given me by everybody was remarkable. A group of Boy Scouts waged an untiring battle to keep back the crowd from 8.30 p.m. until my transport trailer arrived at 11.30 p.m. Captain Shaw, who was in command of an airship during the war, gave me every assistance and carried out all the necessary telephone calls. Councillor Webb, the Chairman of the Portsmouth Gliding Club, was also early on the scene and immediately gave me his aid and hospitality which continued throughout the whole of our stay in Portsmouth.

With this flight the days of Itford Hill were over. It was a time which had furnished indisputable proof that the English country-side was just as suitable for training as for soaring in high performance machines. It had also shown that the movement had taken root quicker than in the other countries; and it remained, now, only to rouse the interest of the other parts of the country.

So far we had not got towed-gliding but were only acquainted with soaring along the slopes and therefore with

the wind direction. To-day having recourse to towed starts and knowledge of thermal flying we can give exhibitions at any time over any kind of country. At that time the success of a meeting was at all times and above all dependent on the weather and for that reason we were not always quite so successful as at Itford Hill. At Portsmouth we flew from Beacon Hill but I myself was later able, on account of the strong south wind, to fly in my "Wien" from Portsdown Hill under first-class conditions and to reach the cumulus clouds as well as fly at times in the strong wind and rain. Once more I awakened interest in the greater long distance flights by a lantern lecture and explained both the theoretical and practical sides of training.

From Portsmouth we went to the Channel Club near Folkestone. The Royal Air Force officers received me as one of themselves, they flew with us, launched the "Zögling" from the slopes and organized everything. Happy is the land which has won such men as these for its aviation.

Once again the English country-side showed to advantage. We flew directly over Folkestone and Magersuppe made a flight of three hours ten minutes in his "Professor," landing on a recreation ground in the centre of the town. It was also at Folkestone that Gus Haller, the young American glider pilot, ran into us. He had gained his "C" certificate at the Wasserkuppe and had now come to learn and help at our meetings. There was probably no better method of introducing himself than the way he did, which was to roll up his sleeves and work like the "devil." From this day onwards he came with us through England and was not only a good friend but probably also saw and learnt much which helped him later in his victories in America. With heavy heart we parted from our R.A.F. friends, all of whom together with their leader Flight Lieutenant Stewart I shall remember with the kindest regards.

From there we went to Weymouth where on Eggardon Hill a site was found which offered an opportunity for real soaring in all directions of the wind. Again there arrived the coaches with thousands of people, again we flew, again the local club practised and again we exchanged experiences with the English pioneers. As everywhere, here also was

a man who while standing modestly in the background was chiefly responsible for all the success, i.e. Captain G. T. R. Hill. I listened with great respect to his reminiscences of how, at night by moonlight, he had made his first flights in order to avoid being ridiculed.

From thence we went to London. A lecture to the London Gliding Club called me there, but immediately afterwards I left for Ilkley in the north. How fortunate are the clubs laying in the mountainous parts of England! Beamsley Beacon was a place where I should like to have stayed longer than was permitted at that time. Long distance flights could have been made there, crossing from mountain to mountain, and if cloudy weather came then flights no less attractive from the sporting point of view than those of the Rhön would have been possible. However, we had no time to put all that to the test, for one cannot do justice to the public and at the same time carry out long distance flights. Our task was above all to arouse interest in gliding, and this was successfully carried out here as at all other places we had been to.

We now went on quickly to Scarborough in order to fly in the north-east. The interest with which we were expected there was really greater than ever. As before there was very little time at our disposal in which to inspect the country-side and nothing requires more care than the selection of a soaring site. On account of its accessibility we had to select Castle Hill as the only place in the immediate neighbourhood which appeared to offer possibilities for soaring. This was probably one of the most romantic spots from which I had ever started. A cliff rose precipitately from the mainland and jutted out to sea. On the day we had to fly, the wind was really too strong. Magersuppe who was the first to start grazed a railing erected around the cliff, flew away over the Castle Hill and descended in the sea. I started badly myself. The machine, which would not climb, was caught by one of the launching crew, swung round and landed somewhat damaged at the starting point.

Much thought has been given to the elucidation of the two flights which were not so successful as the ones we had hitherto made. Those who are acquainted with the currents

and their behaviour on steep slopes understand the conditions perfectly. Previously, on the occasion of my Alpine expedition of 1928, we encountered, over a precipice, vortices which became more powerful as the wind increased in force. Only when the wind is very weak are the currents regular or when the sun's rays are strong enough, through thermal currents, to disperse the vortices. Wherever there is a vertical wall with a horizontal plateau above it a "weather vortex" forms itself on the windward side, which at Scarborough was the angle between the cliff and sea, and its axis runs horizontal. Immediately against the perpendicular wall and directly below the top edge there is a strong down-current which in the case of less steep slopes is an up-current. The wind swirls up from below over the sharp edge and again a vortex is created, a lateral vortex, which again causes the wind to reverse. Only at a height of from thirty to sixty feet above the plateau is the up-current to be found. Owing to the limits of the ground it was necessary to start within the sphere of the lateral vortex but this is not constant at any one place, it forms, becomes larger, breaks up and draws away with the current. In strong winds which build up particularly strong vortices there come moments when a "start" is possible, just as a vortex has broken up and before the next one forms. These phenomena can be noticed from grass thrown up high. On this occasion the wind even blew at times against the main direction and under such conditions successful starts are dependent upon fractions of seconds which it is very difficult to estimate exactly. Even a particularly powerful launch failed to overcome these adverse conditions. The short time at our disposal did not allow us quietly to study the conditions and I had to go on as there was yet another demonstration to give in England. Although, therefore, I was unable to fly properly I should like to express my thanks to the Scarborough Club for their work and to apologize to the launching crew for the fright I gave them when starting.

At high speed I had to drive to London through the night and rain with my "Wien" towed behind the Mercedes car so kindly placed at my disposal by the London Agency

of the Mercedes Co. The slight damage was repaired promptly by the de Havilland Aircraft Works and soon my "Wien" was ready for the last demonstration which was to be before His Royal Highness the Prince of Wales, himself an aviator. Ivinghoe Beacon had been selected for this exhibition and under the guidance of the Chairman, Mr. Ashwell-Cooke, the London Gliding Club had assembled its "Zöglings" and "Prüflings." My "Wien" stood on the hill, which is certainly one of the best in the neighbourhood of London. The wind, however, caused us great anxiety for it was so weak that I was not sure whether soaring would be possible. The Prince, who had arrived in a light aeroplane, first of all devoted his attention to the training methods and I made a flight in a "Prüfling" but the wind was too weak for soaring. I now put all my hopes in the "Wien." The up-currents were, however, so weak that immediately after the start I lost height and even in her I thought I should only be able to glide, but at last I succeeded in gaining a little height until I was soaring high over Ivinghoe Beacon. On calling out "I hope soaring flight will interest your Royal Highness," I received from below the reply, "Yes, indeed, immensely." I landed at the starting point where the Prince of Wales and Prince George, who had also flown over, inspected the "Wien" with great interest, both of them asking me many questions about soaring flight. A second start resulted in another short soaring flight with a landing on the field from which the two aeroplanes left with the Royal visitors. I had now to return quickly to Germany as the Rhön Competitions were about to commence, the next sporting work for me in England being the double cross-Channel flight for the big *Daily Mail* prize.

On the day before the competition, without troubling about the prize, Beardmore crossed the Channel on his "Professor," after being towed and with a strong following wind in beautiful weather. He did not commence the return flight. The crux of a competition lies in simultaneous performance of competitors. The winning of the *Daily Mail* prize was accomplished, in spite of strong head wind and bad weather, under official control and equal

conditions for all competitors. Therein lay the sporting character of this competition. Beardmore's flight is an event by itself, although the personal effort of this pilot, no longer in his first youth, was certainly great.

After the *Daily Mail* flight I accepted an invitation to England. At Hanworth Park, where a large gliding meeting took place on June 28th, I was able to demonstrate my "Wien" and "Austria" before ten thousand spectators, in between the exemplary demonstrations of the English glider pilots. On this day I also managed a flight of an hour's duration over London Air Park in the up-currents under some small cumulus heat clouds. Flt.-Lt. Max Findlay came up in a "Martlet" to fetch me down in time to receive the *Daily Mail* cheque from the hands of His Grace, The Duke of Sutherland. In the succeeding days there were my two cross-country flights from London Air Park to Chatham and back. After a meeting at Blackpool, organized by National Flying Services and where, also, I was able to show my "Wien" in towed flight, I returned to the Rhön.

For the Rhön Competition of 1931 particular attention had been directed towards encouraging talented newcomers, who were spurred to special efforts by difficult tasks. The practice competition provided prizes for the greatest total flying time, for the greatest aggregate altitude, and for distance flights. A minimum of twelve miles distance was stipulated. A new feature was provided by premiums for constructors, i.e., for young pilots who had built their own machines and had attained therewith a minimum altitude of three hundred feet.

In the main competition the requirements had been keyed up very high, having regard to the rapidity of progress. The competition again turned on the greatest distance flown, the minimum requirement being sixty miles. To the initiated it was obvious that the prize for the flight to the Oechsenberg near Vacha and back to the Wasserkuppe, could only be won with the aid of exceptionally favourable conditions. That again being particularly difficult during the competitions, because such conditions are usually reserved by the skilled pilots for their maximum distance

attempts. In the main competition also, the prizes were so allocated that the younger pilots who had not yet accomplished a long distance flight in a Rhön competition, were well encouraged and had chances of success. In recognition of the increasing importance of towed gliding, there was a special prize for a towing competition, in which the winner was the pilot achieving the greatest flying time after being towed to four thousand five hundred feet, i.e. one thousand six hundred and fifty feet above the Wasserkuppe, the landing being required, however, to be made at the altitude of the Wasserkuppe and within a fixed radius of the starting point.

During the first three days of the competition the weather was not particularly favourable, nevertheless this period and the flying I did sufficed for me to realize that my "Wien" was far from being in the condition necessary for so keen a struggle. The machine had been re-covered a few days previously with pure silk for maximum performance, and had been doped with a material I had not previously tried. The covering proved very sensitive to humidity, in dry weather the wings were taut and smooth, but with the least humidity in the atmosphere the covering became so slack that it became wavy. This spoilt the performance to such an extent that in a trial flight I was hardly able to maintain the same altitude of an ordinary "Professor." After taking the advice of the meteorological station, which felt no hesitation in predicting nothing particularly favourable for the next few days, I decided to have the machine re-covered at Kassel, some three hours distance from the Wasserkuppe. On the day after I left there occurred the greatest thunderstorm flying day the Wasserkuppe has ever experienced.

It was a subject fit for a really great artist to record with his brush, for the impressions of that Saturday were incredibly beautiful in their grandeur. That afternoon, with all its display of sharply divided, bright colours, and the charged atmosphere which affected all present, will remain indelibly fixed in the memories of spectators and pilots alike.

It was one of the many competition days so often

experienced by old Rhön-ites. The sun was broiling hot on the southern slope. The bright sunshine was reflected blindingly from the light coloured planes. The pilots and their assistants lay about lazily and sleepily in the shade. Far away in the south-west a black line slowly grew and rose. The men were still lying about as they had been for hours, but the leaders became suddenly wide awake watching acutely the course of the mounting black wall. Then, nobody knew who began but in a moment all the machines were assembled close together on the Wasserkuppe. There they lay waiting, all eyes on the wind indicator. As soon as it veered they could start, as there was still a south wind. It was now certain that the atmospheric disturbance must come over the Kuppe and would not be deviated from its course. It was already lightning : the rain in the background veiling the mountains of the Rhön in the far distance.

At 5.13 p.m. the wind indicator veered, the velocity of the wind desultorily increased and decreased. Hemmer shot forward as first competitor. Almost immediately Groenhoff followed him and with incredible rapidity the next was also off. Within seven minutes all the twelve machines were in the air. Most of them were soon out of sight in the black clouds, and established contact with the "Front." The rapidly approaching storm carried them out of sight with great speed.

At intervals notifications of landings arrived, Hirth and Groenhoff only being missing. Finally late in the evening, Hirth announced that he had landed at Friedeburg near Halle, a distance of one hundred and five miles, and last of all Groenhoff is reported as having come down at Meizendorf near Magdeburg after a flight of one hundred and forty-two miles. At 9.10 p.m. owing to approaching darkness Groenhoff, from an altitude of seven thousand five hundred feet, had seen far away below him a brilliantly lighted town, in the vicinity of which he had to make an emergency landing.

This day of storm flying probably demonstrated more than anything else the important strides made in gliding. On the occasion of my storm flight of 1929, only a single

machine had ventured to do battle with the elements, this year there had been twelve.

The fifth day of the competition was like a sigh of relief after the great event. The flights of the practice competition achieved times up to almost one hour. In the main competition there were no notable results. It was quite different, however, on the following days. I had returned to the Kuppe again with my "Wien" which had been re-covered with exemplary promptitude at Fiesler's in Kassel and tested it on the slope. The machines competing in the main event had again returned. A new contest was expected in the next day or so. On July 28th a flight of nine hours' duration was achieved in the practice competition by Schmid in his machine "Würzburger Generalanzeiger." Künzer in his "Stuttgart" attained an altitude of one thousand two hundred and thirty feet. The main competition again provided a spectacle which the Rhön probably had not seen before. In the battle for the much contested Oechsenberg I started off first. I commenced the fight at the lowest possible altitude which permitted me nevertheless to attain the air current of the Röhn heights, but whilst I was still there gaining altitude I saw a whole squadron of machines coming from the Wasserkuppe. On this day, thickly covered with cumulus clouds, there were eighteen machines in the sky, and every youthful pilot was doing his utmost to emulate the most proficient. Even if they did not venture to make the flight at so low an altitude as I had, they nevertheless all went at it together as, under a particularly large cumulus cloud, they reached altitudes of nine hundred to one thousand five hundred feet above the starting point and followed Groenhoff, who was leading at one thousand nine hundred and fifty feet above starting point. Mayer in his "Aachen" was the only one who tried to keep on the course, and he landed at the foot of the Forest of Thuringen 32.7 miles distant from the Wasserkuppe. The others made for Oechsen but as they were getting away from the Wasserkuppe already I could see that the better pilots were keeping to a higher altitude than the younger and inexperienced ones. Owing to this the majority were obliged to land during the

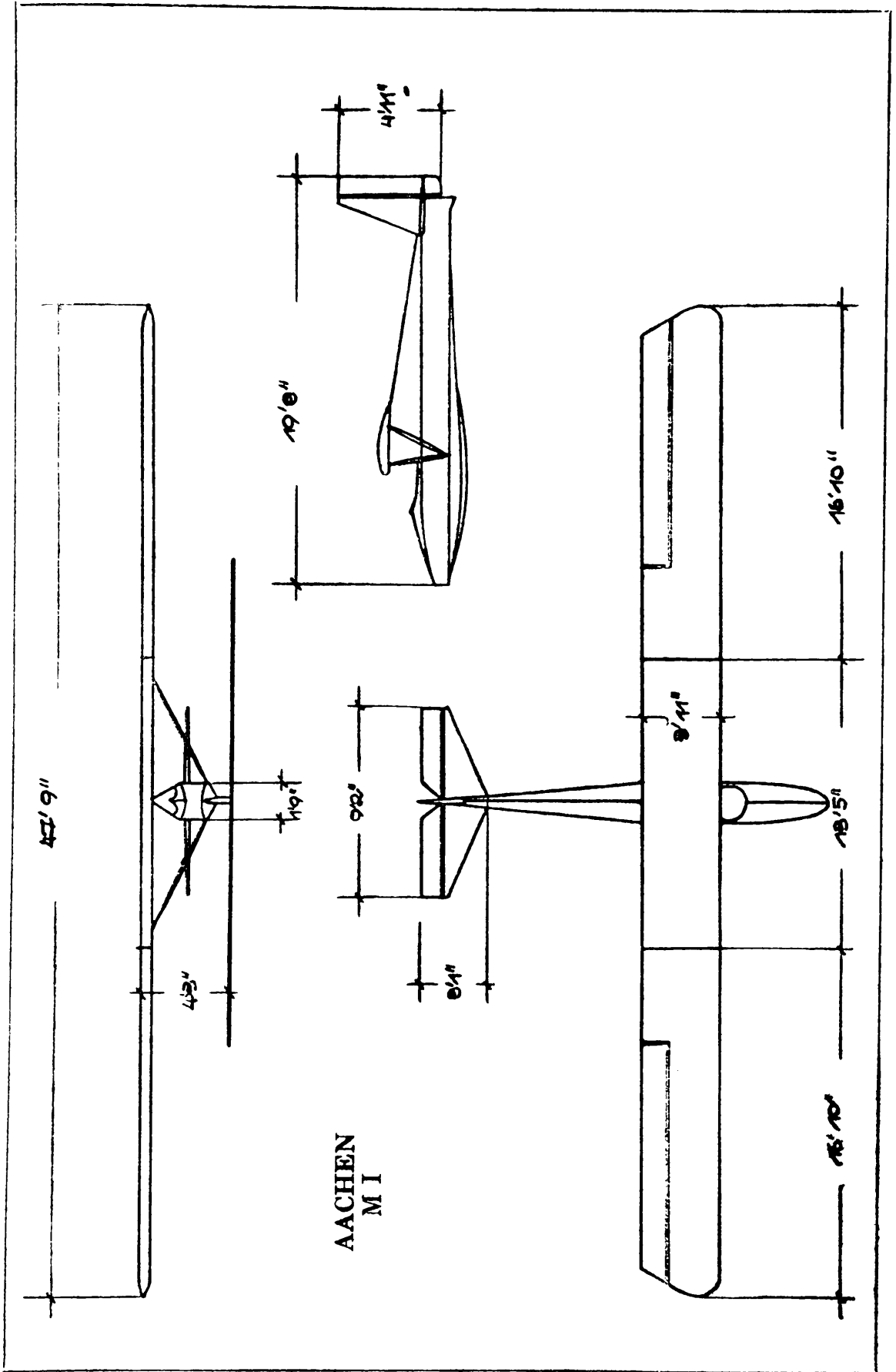

AACHEN
M I

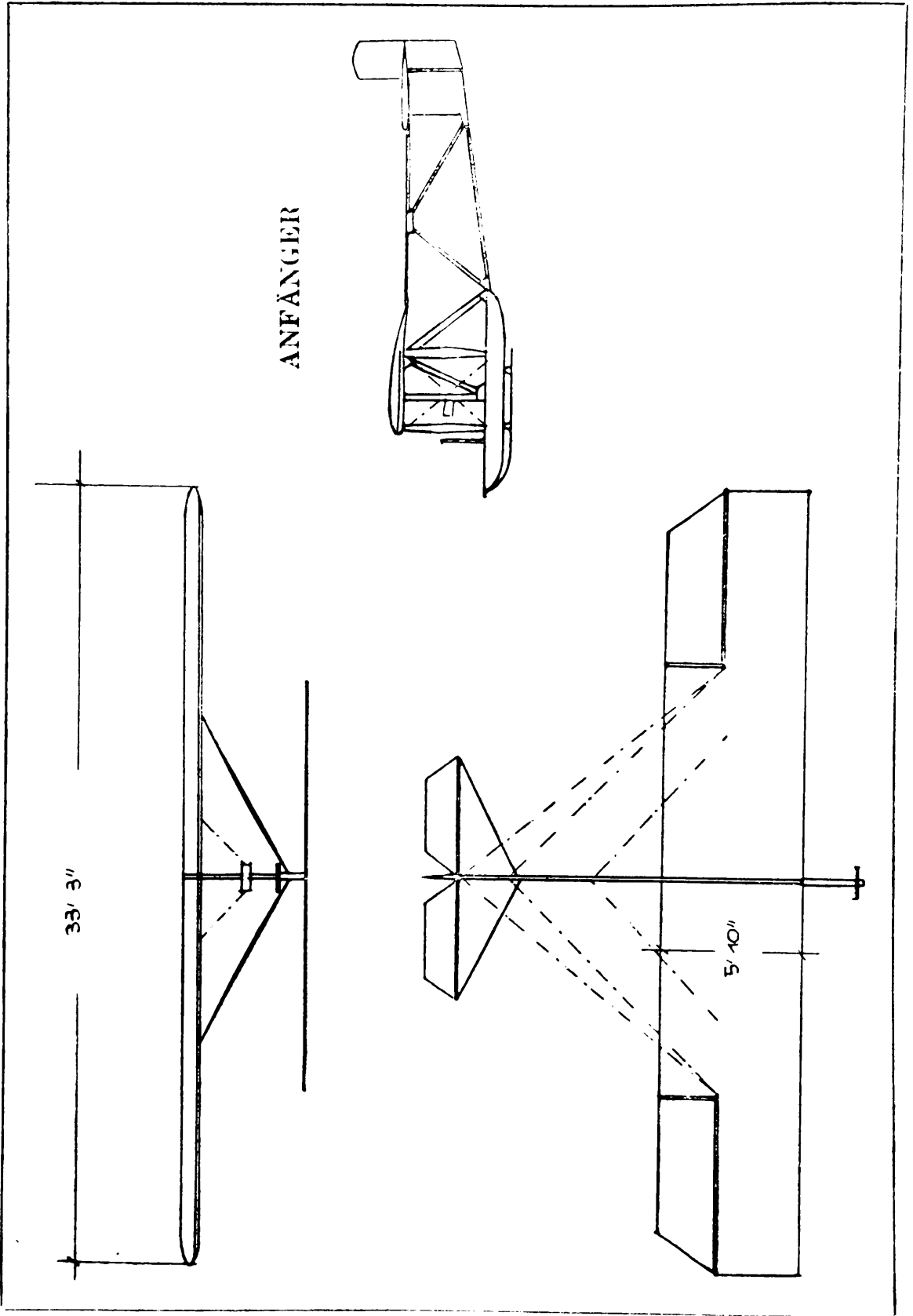

outward flight, whilst the better pilots came down on the return journey. Hirth and Groenhoff having reached Oechsen returned over the same route as they had taken on the outward flight. In order to arrive at the Wasserkuppe in this manner it would have been necessary, making allowance for the direction of the wind, to penetrate the downwind zone under the influence of the Kuppe. In my opinion this plan was not practicable. A return flight would have been possible to the neighbourhood of the Kuppe, which Groenhoff and Hirth proved, but to reach it appeared to me to be particularly difficult. I had, therefore, chosen another way, which, to be sure, at the commencement of the return flight promised considerably greater difficulties than the other route, but if these were successfully overcome then the flight would be assured. So it happened that I saw, as I was fighting late in the evening endeavouring to glide over this void, how the other machines, which like small butterflies in the bright light of day with their white wings standing out in bold relief, were dismantled by the assistants at the landing places in a circle of many miles and put under cover. Thus it was that on this day, the machines of Hirth, Groenhoff, and of the pilots Wallischeck, Hemmer, Stark, Bachem, Röhm and myself were lying in a radius of one and a half to twenty-six miles from the Wasserkuppe. Once again Hirth had landed nearest to the Wasserkuppe. He had landed within a distance of 1.54 miles of the starting point.

I, personally, had not given up the flight for the Oechsenberg prize and glided twice more over the Oechsen, still trying to accomplish the return flight. This was not successful as the heat about the time I reached the most difficult position on the return flight had abated to such an extent that it was no longer possible to get over the valley. On my last trial I executed an almost purely thermal flight, which for six hours fifteen minutes necessitated the most arduous detail work, inseparable from this kind of flying. The longest flying time actually over the Kuppe was attained by Hirth with twenty-four minutes on this day. For this reason the long distance flight to a point could not be competed for.

During this competition cloud gliding was practised quite generally and as a matter of course, and even the pilots in the practice competition frequently reached great altitudes above the Kuppe. On the tenth day of the competition Teichman in the "Offermann," a machine of the "Mayer M2" type, reached a height of one thousand six hundred and twenty feet above starting level. This altitude, however, was exceeded owing to the particularly favourable conditions prevailing on the twelfth day of the competition. Teichmann himself reached two thousand and forty feet, Bihlmaier in a standard "Professor" two thousand five hundred and fifty feet above the start, and Hakenjos in a "Professor" even as high as two thousand five hundred and sixty-five feet, all of these being performances, which a few years ago could not have been achieved even with the very best of machines and by the most experienced pilots. The experiment undertaken by Hemmer, Mayer, Bachem and a number of others, myself among them, of utilizing a purely thermal storm was also interesting. What had been expected in advance took place on this flight. Real thermal storms do not develop typical "fronts." Frequently they hardly advance at all, but divide and follow small mountain valleys, when they sometimes even turn about. I myself have allowed the storm to pass over me without being able to find any up-currents worth anything. Such currents certainly exist but only at considerably higher levels and might in all probability be accompanied by particularly heavy hail. In any event the exploitation of these storms has not been a success. All flights on that day were unimportant.

An interesting innovation in the Rhön competition was the towing flight contest. In order to judge the performances correctly it was specified that the contest had to be carried out in such a manner as to bring all the machines to the same altitude simultaneously. As only one towing machine was available, which at the time of the best heat commenced towing, and as the order of starting was determined by casting lots, luck played a very important part in this contest. I feel I am all the more bound to raise this point as I received the first prize in this contest.

The best times flown after casting off were those of Groenhoff and Hirth with one hour forty-two minutes and one hour twenty-seven minutes respectively, whilst I, who started later, followed with one hour ten minutes. I landed, in accordance with the rules, as the only one above the prescribed height of eight hundred and in a radius of one kilometre. It would be quite conceivable that even if only a few engined machines were available, such a contest could be carried out in such a manner as to give a scale on which performances could be judged correctly. It would only be necessary to tow the machines starting first to a higher altitude corresponding to their sinking speed, so that all the planes at a predetermined time were at a certain height, from which time onward the flying time only would be appraised. It will be absolutely impossible, on account of the varying heat at different hours of the day, to obtain an equal scale for all the machines.

Probably, the most interesting performances of the contest were the distance flights utilizing the heat. The flights over the large towns in the spring of last year, my first distance flights over level terrain in London, my last two flights to Oechsen and the towed flight contest had all, more or less, been thermal flights. The performances put up on August 2nd, among which the high altitudes, already mentioned, attained by the practice pilots and above all by Hakenjos are also included, belong likewise to this newest field of gliding flight. On August 2nd, we had weather conditions very rare in the Rhön district. Particularly hot weather and exceedingly strong east winds prevailed. Groenhoff was the first to disappear after he had reached a high altitude. Hirth started later and quite a considerable time elapsed before he was successful in working his way up high in a thermal current. At approximately seven hundred feet he was able to escape from the Wasserkuppe mountains and he circled up in spirals to two thousand feet. Thermal gliding is only possible by continued circling in an up-current and it is therefore obvious that during this time, one drifts in the direction of the wind. When Hirth had reached this high altitude he found himself about

six miles west of the Wasserkuppe. He now felt his way from up-current to up-current, aided by the up-current "indicators" which are provided for glider pilots by soaring birds and butterflies that have been blown along. When he found himself south of Fulda he met Groenhoff in his "Fafnir" who followed the same tactics under identical conditions. The machines now flew in company which were favourable to both. Birds also circle in large numbers in thermal up-currents of this kind and when one of them begins to ascend out of the large field of influence they all fly to the place where the up-current is, and in a like manner those points are avoided where, as compared with the others, a bird falls. Groenhoff, Hirth and I had carried out these tactics during the thermal soaring after being towed off at the Wasserkuppe and now Hirth and Groenhoff were making use of them in their distance flight. The machines flew in the direction of Frankfurt at a height of three thousand to three thousand five hundred feet, sometimes one and then the other being the higher. Later on during the flight the machines lost sight of each other and finally Groenhoff landed near Usingen, a distance of 64.2 miles from the Wasserkuppe. Hirth who also had lost considerable altitude, was able, however, to work up to a height again: he had adopted the tactics of circling in small thermal currents and after a fight during which he had sunk down to a few hundred feet above the ground had again worked up high, so that between Oberlahnstein and Koblenz he reached the Rhein at an altitude of three thousand feet. He further succeeded in crossing the Mosel but with the approaching evening the heat abated. Hirth tried to reach the cliffs of the Eifel along which he wished to soar by means of the up-current from them. He landed near Brohl after covering a distance of one hundred and nineteen miles. This was by far the greatest distance which had ever been flown from the Wasserkuppe in this direction.

In this magnificent contest also I had been unable to participate. In the opinion of the doctor I ought really to have been in bed. To say the least he did not allow me to eat anything and wrote a diet card for me which even a

baby would have taken as an insult. When the last day of the competition arrived I had for the five preceding days existed on a few plates of soup. The day also did not look particularly promising. Up to the time I started, the longest flight for the day had been one of nine minutes. It was not possible for any machine to stay up over the slope of the mountain. There was practically no wind. Only a few gusts of heat now and then presented the opportunity of gaining altitude, leaving one at the next moment in the lurch again. Immediately I started I fell away so much under starting height and even got lower than the height of the Eube. After I had battled there for an hour I succeeded in getting into a thermal current in which, continually circling, I worked up. Continually gaining more and more height I finally said good-bye to the Kuppe at one thousand and fifty feet above start and saw below me other machines of the main competition endeavouring to follow me. All these efforts, however, had to be abandoned after a short flight of a few minutes. I had arrived in a region, however, in which I remained during the whole of the flight and which was at a height of between three thousand six hundred to four thousand eight hundred feet. Further my course lay towards the west. I drew away towards Fulda, but lost altitude in down-draughts. I then again got in an imperceptible up-current, cautiously worked in and gained height again. It was a fight with an invisible opponent which made it the more fascinating. The up-currents, whose connexion with the ground for the most part cannot be perceived, are supposed to be somewhere about. The machine was flown in one direction, lost altitude and kept the attention constantly to a high pitch in order to be able to feel the slightest puff of up-wind. Upon which one immediately turns so as to avoid flying through it, commences to circle and the greatest care is taken to work one's way cautiously into the region of the strongest influence of the current. In this manner I went in a northerly direction past Marburg until I saw lying a long way beneath me the Rothaar mountains. However, the mountains no longer occupied my attention. Indeed, in the prevailing calm they would not have assisted me.

The only thing of importance was to locate the thermal currents again, make use of these to attain the highest altitude one could in them, or until they broke up in order to ascend again at another point. Again I had been on the way for over six hours and again the heat suddenly abated in the evening, as we had already noticed in all our flights up to the present. I had as a matter of fact made Münster my goal, where I had begun my work of gliding over level terrain in the spring of this year. I was, however, compelled to descend before reaching there. I had flown from the Wasserkuppe to Westphalia. I landed near Freienohl in the neighbourhood of Arnsberg after covering a distance of ninety-six miles.

All this is merely preliminary to the great thermal flights which the next few years will bring.

Allusion must be made to a comrade, Otto Fuchs, who was unable to fly with us although we had all looked forward to his appearance and success. Owing to an accident such as is associated with aviation he injured himself so badly on the first day of the competition that he could not take part in the contest. We, therefore, have missing from the list of winners, the name of one who otherwise would be included in it.

With most amazing rapidity gliding has made great progress all over the world. England arranged a repetition of the Inter-Club Competitions which had become so popular the preceding year. The first competition of this kind had already taken place at Easter. During these days the pioneer work of Lowe-Wylde in towing by motor-car had become quite clear even to those of slight discernment. The noted gliding pilots Captain Stratton, Turner, and Captain Needham were on the list of winners with Mr. Mole and Mr. Reffel. On August 2nd Mole improved the English duration record in a "Professor" up to six hours ten minutes. In Honolulu, Lieutenant T. C. Crain, an officer of the United States Army, flew sixteen hours thirty-eight minutes thus breaking the German duration record. All over the world small groups are forming, small contests are taking place and very often good performances are being achieved.

Partly overlapping the Rhön competition, the American Competition had once again taken place at Elmira, New York.

At the 1931 Competition held from August 2nd to the 16th little flying could be done compared with the preceding year, as a consequence of the absence of sufficient wind. More than half of the participating machines were of the Franklin Utility type, which, owing to their less efficient gliding angle as light wind machines, were badly handicapped as compared with the high performance machines. They have, however, distinguished themselves in schools devoted to towing by motor-cars. A new machine there is the "Haller Hawk," constructed by the Haller Hirth Sailplane Corp. of Pittsburg, two of which were flown in the competition.

During the competition Gus Haller became ill and was not permitted to fly his machine, the well known "Schloss Mainberg" to be flown by Schempp, who succeeded in achieving with it not only the distance flight of 14.4 miles but also the highest altitude of two thousand eight hundred and fifty feet and the longest total flying time of eighteen hours forty-two minutes. Hawley Bowlus was second in the distance flight with twelve miles, whilst Hastings in addition to the first prize for a duration flight of seven hours thirty minutes also won the second prize for an altitude of one thousand eight hundred feet and the third prize for distance. Stickler was second with seven hours twenty-eight minutes for duration and Barton won the first for best landing at fixed destination. The desire of all the pilots to try for the distance gliding is worthy of note. A lady, Mrs. Holderman, also participated in the competition and she succeeded in putting up the duration record for women of forty-nine minutes. It is further worth while noting the fact that the first four for the prize for the best landing at fixed destination were pilots who had just passed their "C" test during the competition. Unfortunately there were also three accidents to be noted, one of which is to be attributed to the inferior construction of the machine. The parties involved were obliged to withdraw from the competition on account of the injuries they had sustained.

From September 10th to 24th an international competition was held in France, which was accompanied by exceedingly unfavourable wind conditions. I took part in this as the only foreigner, but the conditions as described above offered no opportunity for particularly good performances. The wind permitted me only on two occasions to fly for any length of time and then it was a wearisome battle with the thick fog, which for minutes at a stretch hid everything, approaching from over the sea. On this flight I remained in the air four hours forty-two minutes. Unfortunately longer distance flights were not possible. The up-currents on the slopes of the Vauville terrain were particularly strong and on my first flight I was able, in a current from the slope, to climb to an altitude of one thousand seven hundred and ten feet.

It was of great interest to me to notice that during the whole of the competition, the many flights of the school machines, even the very short ones, were almost always made with the assistance of the motor winch. Another proof of the advantages of this practical method.

With the exception of Abrial who flew a "Kassel 25," the French pilots, among them Fauvel, Barbot, Appert and Bouvier, had fast and heavy machines and, owing to the head wind, were only able to make short gliding flights down to the beach. Abrial on one occasion made a flight of fifteen minutes duration.

Particularly hearty co-operation linked us with the University Flying Club under the direction of Jean Rippert who came off victorious as winner of the training competition. "Père" Lagasse was director and organizer of this competition and at the conclusion was most heartily praised by everyone.

Immediately after the French competition the session of the International Commission for Gliding Flight began at London. In connexion herewith a competition took place on October 3rd and 4th at Balsdean which again in consequence of unfavourable wind conditions did not permit good performances being made. The visitors to the session were present at this competition.

These days certainly contributed to bring the glider

pilots of the world nearer to each other. It was resolved to hold an international competition annually in one of the adjacent countries and institute investigations into gliding in the tropics.

The decision that in the opinion of the commission towed flight is not suitable for obtaining the same flying experience as in the case of flying over a slope unfortunately shows that the experience of those who have already considerably practised this kind of flying has not received sufficient consideration.

It would lead too far to go exhaustively into the details of the gliding movement, as it is being taken up very extensively now throughout the world. A lively feeling of reciprocity between individual countries is now setting in. Not only are the European countries devoting themselves to the new style of flying, but engineless flight is also advancing into the most distant parts of the world.

Towed flight, particularly towing by automobile, has been rapidly adopted by America, and in England its best partisan is to be found in the person of the indefatigable Lowe-Wylde. Repercussions of the movement emanating from America and England are now being felt in Germany. Every year we receive with pleasure the representatives of the whole world both in the big competitions and in the gliding schools of Germany. As a result of the work put into gliding flight all over the world, it may be that the performances in gliding during the coming year will be scattered widely over the earth.

